

High-speed 1T 8051-based Flash MCU, 256 bytes SRAM, 8K bytes Flash, 128 bytes independent EEPROM, 12-bit ADC, Six 8-bit PWM Outputs, Three Timer/Counters, UART.

1 General Description

The SC92F735X (hereinafter referred to as the SC92F735X) is a kind of enhanced high-speed 1T 8051-based industrial Flash Microcontroller unit (MCU), in which the instruction system is completely compatible with standard 8051 product series.

The SC92F735X is integrated with 8K bytes Flash ROM, 256 bytes SRAM, 128 bytes EEPROM, up to 18 General-purpose I/Os (GPIO), 6 external interrupters, three 16-bit timers, 9-channel 12-bit high-precision ADC, 6-channel independent 8-bit PWM, IO ports driven hierarchical control (P0 and P2 ports) with 4-level drive capability, internal $\pm 1\%$ high-precision 24/12/6/2MHz high-frequency oscillator and $\pm 4\%$ precision low-frequency 128 kHz oscillator, UART communication interface and other resources. To improve the reliability and simplify the circuit design, the SC92F735X is also built in with 4-level optional LVR voltage, 2.4V ADC reference voltage and other high-reliability circuits.

The SC92F735X features excellent anti-interference performance, which make it possible to be widely applied to industrial control system, such as Internet of Things, intelligent home appliances, Charger, power supply, model airplane, interphone, wireless communication, gaming peripherals and consumer applications.

2 Features

Operating Voltage: 2.4V ~ 5.5V

Operating Temperature: -40 ~ 85°C

Package:

SC92F7352Q20R (QFN20)
SC92F7352X20U (TSSOP20)
SC92F7352M20U (SOP20)
SC92F7352N20U (NSOP20)
SC92F7351M16U (SOP16)
SC92F7350M08U (SOP8)

Core: 1T 8051

Flash ROM: 8K bytes Flash ROM (MOVC prohibited addressing 0000H ~ 00FFH) can be rewritten for 10,000 times

IAP: Code option into 0K, 0.5K, 1K or 8K

EEPROM: independent 128 bytes EEPROM can be rewritten for 100,000 times. The data written-in has more than 10-year preservation life.

SRAM: Internal 256 bytes

System Clock (f_{SYS}):

- Built-in high-frequency 24MHz oscillator (f_{HRC})
- As the system clock source, f_{SYS} can be set to 24MHz (3.7-5.5V), 12/6/2MHz (2.4-5.5V) by programmer selection.
- Frequency Error: Suitable for (4.0V ~ 5.5V) and (-20 ~ 85°C) application environment, no more than $\pm 1\%$ of frequency error

Built-in Low-Frequency 128 kHz Oscillator (LRC):

- Clock source of Base Timer (BTM), which can wake up the SC92F735X from stop mode
- Clock source of Watch Dog Timer (WDT)
- Frequency Error: Suitable for 2.9V ~ 5.5V and -20 ~ 85°C application environment, no more than $\pm 4\%$ of frequency error

Low-voltage Reset (LVR):

- 4-level LVR voltage options: 4.3V, 3.7V, 2.9V, 2.3V
- The default is the Code Option value selected by the user

Flash Programming interface:

- 2-wire JTAG programming interface

Interruption (INT):

- 9 interrupt sources: Timer0, Timer1, Timer2, INT0, INT2, ADC, PWM, UART and Base Timer.
- 2 external interrupt vectors shared by 6 interrupt ports, all of which can be defined in rising-edge, falling-edge or dual-edge trigger mode.
- Two-level interrupt priority capability

Digital Peripheral:

- Up to 18 bidirectional independently

controllable I/O interfaces, able to configure pull-high resistor independently

- P0/P2 ports with 4-level drive capability
- All I/Os equipped with sink current drive capability (47 mA)
- 11-bit WDT with optional clock division ratio
- 3 standard 80C51 Timer/Counters: Timer0, Timer1 and Timer2
- Six 8-bit PWM output channels with variable period and individual duty cycle
- 5 I/Os as output of the 1/2-bias LCD COM
- 1 independent communication interface: UART

Analog Peripheral:

- 9-channel 12-bit ± 2 LSB ADC
 - Built-in 2.4V reference voltage
 - 2 options for ADC reference voltage: V_{DD} and internal 2.4V
 - Internal one-channel ADC, where V_{DD} can be measured directly
 - ADC conversion completion interrupt

Power Saving Mode:

- IDLE Mode: can be woken up by any interrupt.
- STOP Mode: can be woken up by INT0 , INT2 and Base Timer

Preliminary

Naming Rules for 92 Series Products

Name	SC	92	F	7	3	5	2	X	M	20	U
S/R	①	②	③	④	⑤	⑥	⑦	⑧	⑨	⑩	⑪

S/R	Meaning
①	SinOne Chip abbreviation
②	Name of product series
③	Product Type (F: Flash MCU)
④	Serial Number: 7: GP Series, 8: TK series
⑤	ROM Size: 1 for 2K, 2 for 4K, 3 for 8K, 4 for 16K and 5 for 32K...
⑥	Subseries Number.: 0 ~ 9, A ~ Z
⑦	Number of Pins: 0: 8pin, 1: 16pin, 2: 20pin, 3: 28pin, 5: 32pin, 6: 44pin, 7: 48pin, 8: 64pin, 9: 100pin
⑧	Version Number: (default, B, C, D)
⑨	Package Type: (D: DIP; M: SOP; X: TSSOP; N: NSOP; F: QFP; P: LQFP; Q: QFN; K: SKDIP)
⑩	Number of Pins.
⑪	Packaging Mode: (U: Tube; R: Tray; T: Reel)

Contents

1 GENERAL DESCRIPTION	1
2 FEATURES	1
NAMING RULES FOR 92 SERIES PRODUCTS	3
CONTENTS	4
3 PIN DESCRIPTION	7
3.1 PinConfiguration	7
3.2 Pin Definition	9
4 INNER BLOCK DIAGRAM	11
5 FLASH ROM AND SRAM STRUCTURE	12
5.1 Flash Rom.....	12
5.2 Customer Option Area (User Programming Setting)	13
5.2.1 Option-Related SFR Operating Instructions	16
5.3 SRAM.....	16
5.3.1 Internal 256 bytes SRAM.....	16
6 SPECIAL FUNCTION REGISTER (SFR)	18
6.1 SFR Mapping	18
6.2 SFR Instructions	20
6.2.1 Introduction to 8051 CPU Core Commonly-used Special function Registers	23
7 POWER, RESET AND CLOCK	25
7.1 Power Circuit.....	25
7.2 Power-on Reset Process.....	25
7.2.1 Reset Stage	25
7.2.2 Loading Information Stage.....	25
7.2.3 Normal Operating Stage	26
7.3 Reset Mode.....	26
7.3.1 External Reset	26
7.3.2 Low-voltage Reset (LVR).....	26
7.3.3 Power-on Reset (POR).....	27
7.3.4 WatchDog Reset (WDT)	27
7.3.5 Reset Initial State.....	29
7.4 High-speed RC Oscillator Circuit	31
7.5 Low- frequency RC Oscillator and Low- frequency Clock Timer.....	33

7.6 STOP Mode and IDLE Mode.....	34
8 CPU AND FUNCTION SYSTEM	36
8.1 CPU.....	36
8.2 Addressing Mode.....	36
8.2.1 Immediate Addressing	36
8.2.2 Direct Addressing	36
8.2.3 Indirect Addressing	37
8.2.4 Register Addressing	37
8.2.5 Relative Addressing	37
8.2.6 Indexed Addressing	37
8.2.7 Bits Addressing.....	37
9 INTERRUPT	37
9.1 Interrupt Source and Vector	38
9.2 Interrupt Structure Diagram.....	40
9.3 Interrupt Priority.....	41
9.4 Interrupt Processing Flow.....	41
9.5 Interrupt-related SFR Registers	41
10 TIMER / EVENT COUNTER TIMER0 AND TIMER1	47
10.1 T0 and T1-related Special function Registers.....	48
10.2 T0 Operating Mode	53
10.3 T1 Operating Mode	54
11 TIMER COUNTER TIMER2.....	57
11.1 T2-related SFR.....	57
11.2 T2 Operating Mode	60
12 PWM	62
12.1 PWM block Diagram	62
12.2 PWM-related SFR Registers.....	63
12.3 PWM Waveform and Directions.....	71
13 GP I/O	73
13.1 GPIO Structure Diagram.....	73
13.2 I/O Port-related Registers.....	74
14 SOFTWARE LCD DRIVER.....	78

14.1 Software LCD Drives Relevant Registers.....	78
15 UART.....	79
15.1 UART-related Registers.....	79
15.2 Baud rate of serial communication.....	81
16 ANALOG-TO-DIGITAL CONVERTER (ADC).....	82
16.1 ADC-related Registers.....	82
16.2 ADC Conversion Steps.....	87
17 EEPROM AND IAP OPERATIONS.....	88
17.1 EEPROM / IAP Operating-related Registers.....	88
17.2 EEPROM / IAP Operating Procedures:	92
17.2.1 128 bytes Independent EEPROM Operating Demo programme	93
17.2.2 8 Kbytes Code memory IAP Operating Demo programme	94
18 ELECTRICAL CHARACTERISTICS.....	96
18.1 Absolute Maximum Ratings.....	96
18.2 Recommended Operating Conditions	96
18.3 DC Electrical Features.....	96
18.4 AC Electrical Features.....	99
18.5 ADC Electrical Features	100
19 ORDERING INFORMATION.....	102
20 PACKAGEING INFORMATION.....	103
21 REVISION HISTORY.....	109

3 Pin Description

3.1 PinConfiguration

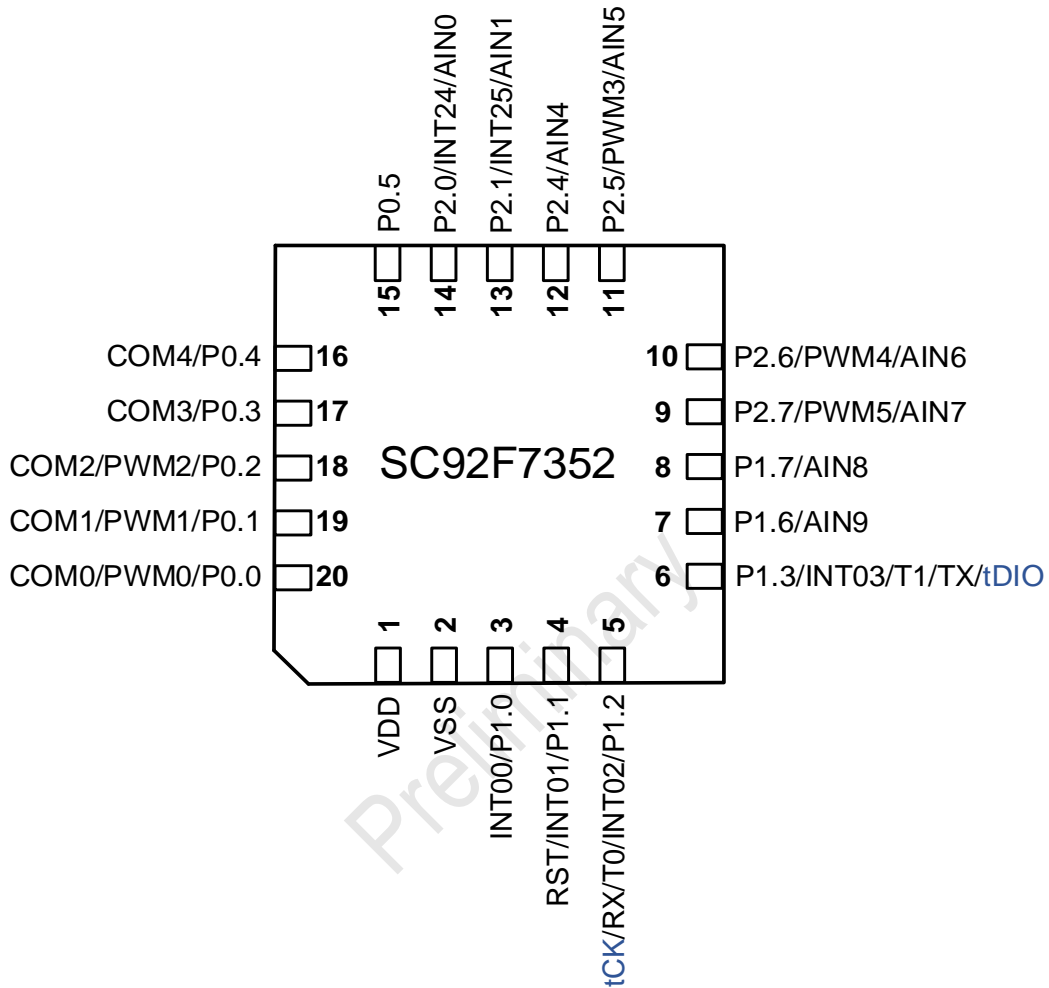

The SC92F7352 Pin Diagram (QFN20)

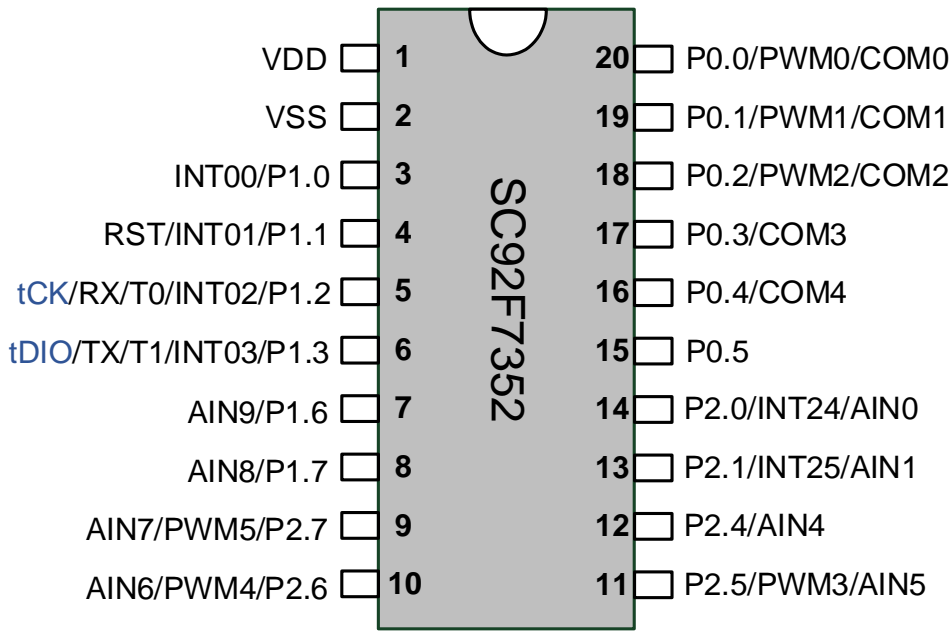

The SC92F7352 Pin Diagram (TSSOP20、SOP20、NSOP20)

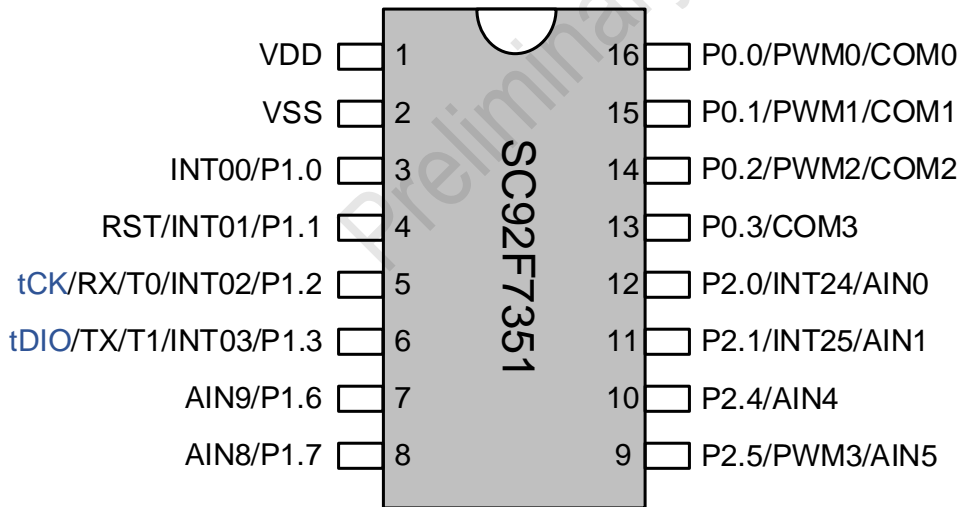

The SC92F7351 Pin Diagram

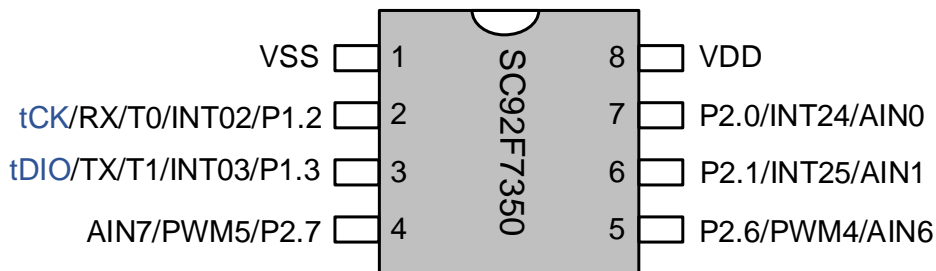

The SC92F7350 Pin Diagram

3.2 Pin Definition

Pin #			Pin Name	Type	Description
20PIN	16PIN	8PIN			
1	1	8	VDD	Power	Power
2	2	1	VSS	Power	Ground
3	3	-	P1.0/INT00	I/O	P1.0: GPIO P1.0 INT00: Input 0 of external interrupt 0
4	4	-	P1.1/INT01/RST	I/O	P1.1: GPIO P1.1 INT01: Input 1 of external interrupt 0 RST: Reset Pin
5	5	2	P1.2/INT02/T0/RX/tCK	I/O	P1.2: GPIO P1.2 INT02: Input 2 of external interrupt 0 T0: Timer/Counter 0 External Input RX: UART Receiver tCK: Programming and Emulation Clock Pin
6	6	3	P1.3/INT03/T1/TX/tDIO	I/O	P1.3: GPIO P1.3 INT03: Input 3 of external interrupt 0 T1: Timer/Counter 1 External Input TX: UART Transmitter tDIO: Programming and Emulation Data Pin
7	7	-	P1.6/AIN9	I/O	P1.6: GPIO P1.6 AIN9: ADC Input Channel 9
8	8	-	P1.7/AIN8	I/O	P1.7: GPIO P1.7 AIN8: ADC Input Channel 8
9	-	4	P2.7/PWM5/AIN7	I/O	P2.7: GPIO P2.7 PWM5: PWM5 Output AIN7: ADC Input Channel 7
10	-	5	P2.6/PWM4/AIN6	I/O	P2.6: GPIO P2.6 PWM4: PWM4 Output AIN6: ADC Input Channel 6
11	9	-	P2.5/PWM3/AIN5	I/O	P2.5: GPIO P2.5 PWM3: PWM3 Output AIN5: ADC Input Channel 5
12	10	-	P2.4/AIN4	I/O	P2.4: GPIO P2.4 AIN4: ADC Input Channel 4
13	11	6	P2.1/INT25/AIN1	I/O	P2.1: GPIO P2.1 INT25: Input 5 of external interrupt 2 AIN1: ADC Input Channel 1
14	12	7	P2.0/INT24/AIN0	I/O	P2.0: GPIO P2.0 INT24: Input 4 of external interrupt 2 AIN0: ADC Input Channel 0
15	-	-	P0.5	I/O	P0.5: GPIO P0.5
16	-	-	P0.4/COM4	I/O	P0.4: GPIO P0.4 COM4: LCD common drive output 4
17	13	-	P0.3/COM3	I/O	P0.3: GPIO P0.3 COM3: LCD common drive output 3

18	14	-	P0.2/PWM2/COM2	I/O	P0.2: GPIO P0.2 PWM2: PWM2 Output COM2: LCD common drive output 2
19	15	-	P0.1/PWM1/COM1	I/O	P0.1: GPIO P0.1 PWM1: PWM1 Output COM1: LCD common drive output 1
20	16	-	P0.0/PWM0/COM0	I/O	P0.0: GPIO P0.0 PWM0: PWM0 Output COM0: LCD common drive output 0

Preliminary

High-speed 1T 8051-based Flash MCU, 256 bytes SRAM, 8K bytes Flash, 128 bytes independent EEPROM, 12-bit ADC, Six 8-bit PWM Outputs, Three Timer/Counters, UART.

4 Inner Block Diagram

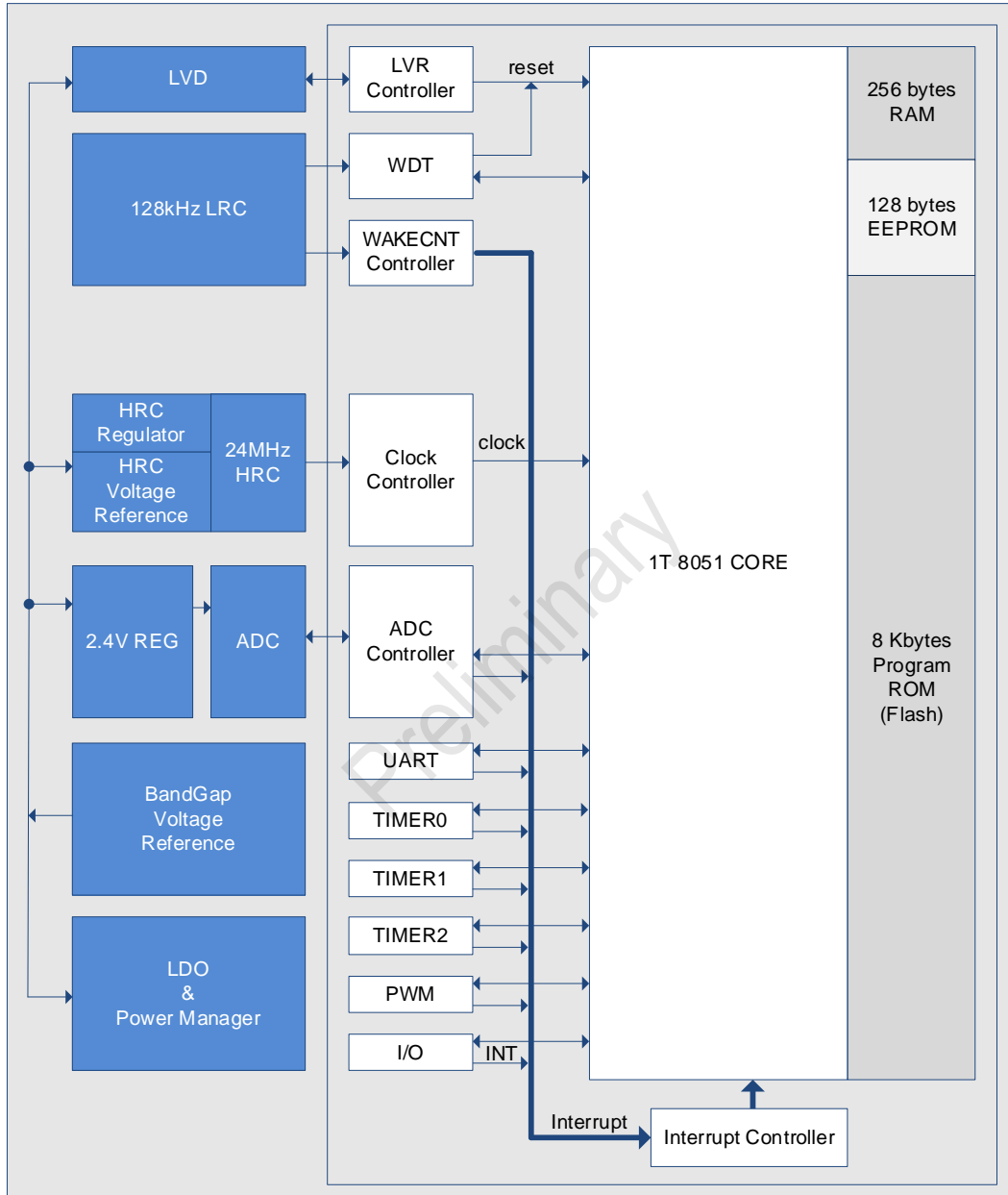

The SC92F735X BLOCK DIAGRAM

5 Flash ROM and SRAM Structure

The structures of the SC92F735X's Flash ROM and SRAM are shown as follows:

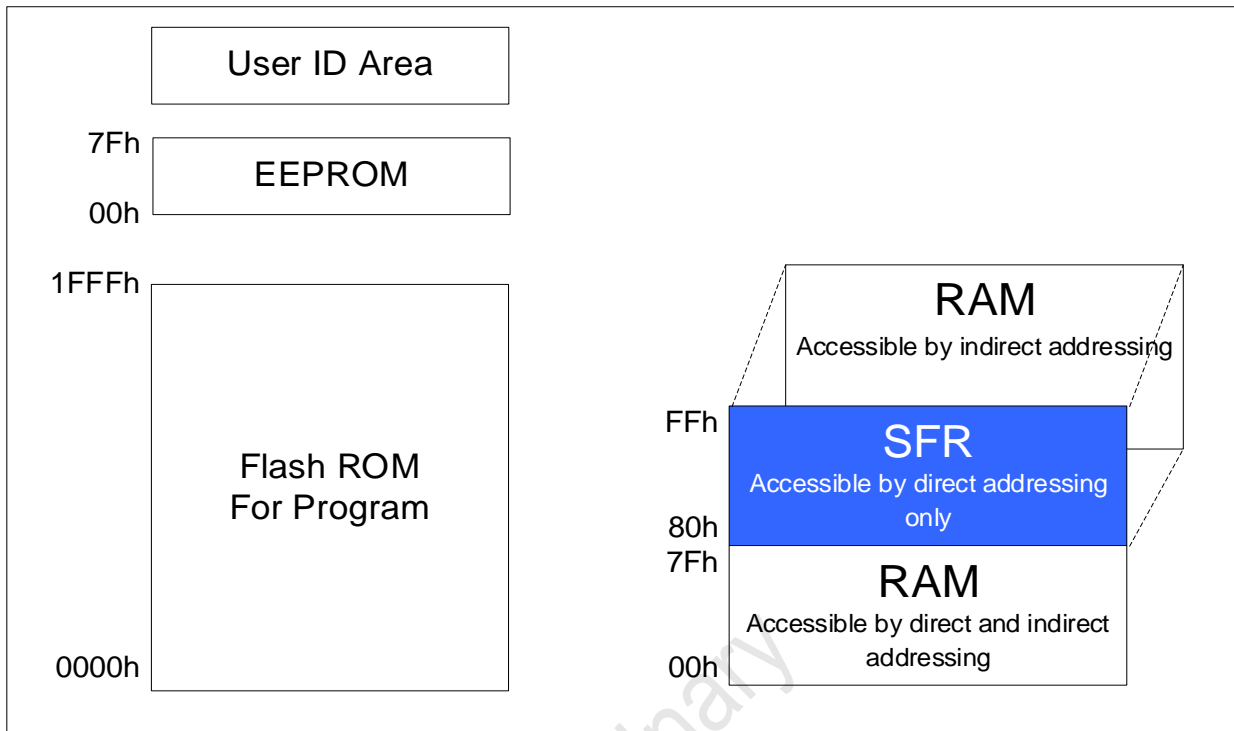

Flash ROM and SRAM Structure Diagram

5.1 Flash Rom

The SC92F735X provides 8K bytes of Flash ROM with the ROM address of 0000H ~ 1FFFH. These 8K bytes of Flash ROM can be rewritten 10,000 times, which is able to programming and erasing by specialized ICP programming device (SOC PRO52/DPT52/SC LINK) provided by SinOne. MOVC instruction is non-addressable within 256 bytes (address of 0000H ~ 00FFH).

EEPROM is an area separated from 8K bytes ROM with the address of 00H ~ 7FH, which can be accessed by single-byte reading and writing operations in the programme; for more details, refer to [17 EEPROM and IAP Operations](#).

User ID area: the user ID is written in the factory, and the user can only read it, for more details, refer to [17 EEPROM and IAP Operations](#).

8 Kbytes Flash ROM of SC92F735X can provide BLANK, PROGRAM, VERIFY and ERASE functions, but it does not provide READ function. This Flash ROM and EEPROM usually do not need to be erased before writing, and the new data can be overwritten by writing data directly.

The SC92F735X Flash ROM can be programmed by tDIO, tCK, VDD and VSS, with its specific connection shown as follows:

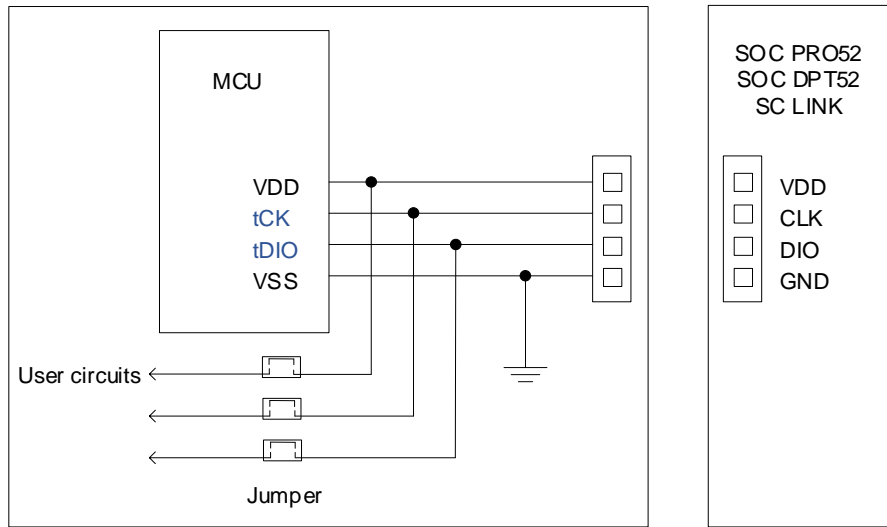

ICP Mode Flash Writer Programming Connection Diagram

5.2 Customer Option Area (User Programming Setting)

A separate Flash area is embedded inside the SC92F735X, called Customer Option area, to save the user's presets. These presets will be written into IC when programming and loaded into SFR as default values during reset.

Symbol	Address	Description	7	6	5	4	3	2	1	0	Initial value
OP_HRCR	83H@FFH	High-frequency RC oscillation frequency regulation	OP_HRCR[7: 0]								nnnnnnnb
OP_CTM0	C1H@FFH	Customer Option Register 0	ENWDT	-	SCLKS[1: 0]		DISRST	DISLVR	LVRS[1: 0]		nxnnnnnb
OP_CTM1	C2H@FFH	Customer Option Register 1	VREFS	-	-	-	IAPS[1: 0]		-	-	nxxxnxxb

OP_HRCR (83H@FFH) System Clock Change Register (Read/Write)

Bit Number	7	6	5	4	3	2	1	0
Bit Symbol	OP_HRCR[7: 0]							
R/W	R/W							
POR	n	n	n	n	n	n	n	n

Bit Number	Bit Symbol	Description
7 ~ 0	OP_HRCR[7: 0]	Internal high-frequency RC frequency adjustment Central value 10000000b corresponds to HRC central frequency, the larger the value is, the faster the frequency will be, vice versa.

OP_CTM0 (C1H@FFH) Customer Option Register0 (Read/Write)

Bit Number	7	6	5	4	3	2	1	0
Bit Symbol	ENWDT	-	SCLKS[1: 0]		DISRST	DISLVR	LVRS[1: 0]	
R/W	R/W	-	R/W		R/W	R/W	R/W	
POR	n	x	n		n	n	n	

Bit Number	Bit Symbol	Description
7	ENWDT	WatchDog (WDT) control bit (This bit is transferred by the system to the value set by the user Code Option) 0: WDT invalid 1: WDT valid (WDT stops counting during IAP execution)
5 ~ 4	SCLKS[1: 0]	System clock frequency selection bits 00: System clock frequency is HRC frequency divided by 1; 01: System clock frequency is HRC frequency divided by 2; 10: System clock frequency is HRC frequency divided by 4; 11: System clock frequency is HRC frequency divided by 12;
3	DISRST	IO/RST selection bit 0: configure P1.1 as External Reset input pin 1: configure P1.1 as GPIO

2	DISLVR	LVR control bit 0: LVR valid 1: LVR invalid
1 ~ 0	LVRS [1: 0]	LVR voltage selection bits 11: 4.3V reset 10: 3.7 V reset 01: 2.9V reset 00: 2.3 V reset

OP_CTM1 (C2H@FFH) Customer Option Register1 (Read/Write)

Bit Number	7	6	5	4	3	2	1	0
Bit Symbol	VREFS	-	-	-	IAPS[1: 0]		-	-
R/W	R/W	-	-	-	R/W	R/W	-	-
POR	n	x	x	x	n	n	x	x

Bit Number	Bit Mnemonic	Description
7	VREFS	Reference voltage selection bit (Initial values are configured by the user and loaded from Code Options) 0: Configure ADC VREF as V_{DD} 1: Configure ADC VREF as internally correct 2.4V
3 ~ 2	IAPS[1: 0]	IAP Area Selection Bits 00: Code memory prohibits IAP operations, only EEPROM data memory is used for data storage 01: last 0.5k code memory allows IAP operation (1E00H ~ 1FFFH) 10: Last 1k code memory allows IAP operation (1C00H ~ 1FFFH) 11: All code memory allows IAP operation (0000H ~ 1FFFH)

6 ~ 4, 1 ~ 0	-	Reserved
--------------	---	----------

5.2.1 Option-Related SFR Operating Instructions

Option-related SFR reading and writing operations are controlled by both OPINX and OPREG registers, with its respective position of Option SFR depending on OPINX and its value written to option-related SFR depending on register OPREG:

Symbol	Address	Description		POR
OPINX	FEH	Option Pointer	OPINX[7: 0]	00000000b
OPREG	FFH	Option Register	OPREG[7: 0]	nnnnnnnnb

When operating Option-related SFR, register OPINX stores the address of option-related registers and register OPREG stores corresponding value.

For example: To configure OP_HRCR as 0x01, specific operation method is shown below:

C program example:

```
OPINX = 0x83;           //Write OP_HRCR address into OPINX register
OPREG = 0x01;          //Write 0x01 into OPREG register (the value to be written into OP_HRCR register)
```

Assembler program example:

```
MOV OPINX, #83H        ;Write OP_HRCR address into OPINX register
MOV OPREG, #01H        ;Write 0x01 into OPREG register (the value to be written into OP_HRCR register)
```

Note: It is forbidden to write any value beyond SFR address of Customer Option region into OPINX register! Or else, it may cause abnormal system operation

5.3 SRAM

The SRAM of the SC92F735X Microcontroller Unit is internal 256 bytes RAM. The address of Internal RAM range from 00H to FFH, including high 128 bytes (address of from 80H to FFH) only addressed indirectly and low 128 bytes (address of from 00H to 7FH) addressed both directly and indirectly).

The address of special function register SFR is also from 80H to FFH. But the difference between SFR and internal high 128 bytes SRAM is that the former is addressed directly but the latter addressed indirectly only.

5.3.1 Internal 256 bytes SRAM

Internal low 128 bytes SRAM area is divided into three parts: ① Register bank 0 ~ 3, address from 00H to 1FH. The active bank is selected by bits RS1 and RS0 of PSW register. Using Register bank 0 ~ 3 can accelerate arithmetic speed; ② Bit addressing area, 20H ~ 2FH; user can use it as normal RAM or bitwise addressing RAM; for the latter, the bit address is from 00H to 7FH (bitwise addressing is different from normal SRAM byte-oriented

addressing), which can be distinguished by instructions in programme; ③ User RAM and stack area, the 8-bit stack pointer will point to stack area after the SC92F735X reset; in general, users can set initial value in initializer, which is recommended to configure in the unit interval from E0H to FFH.

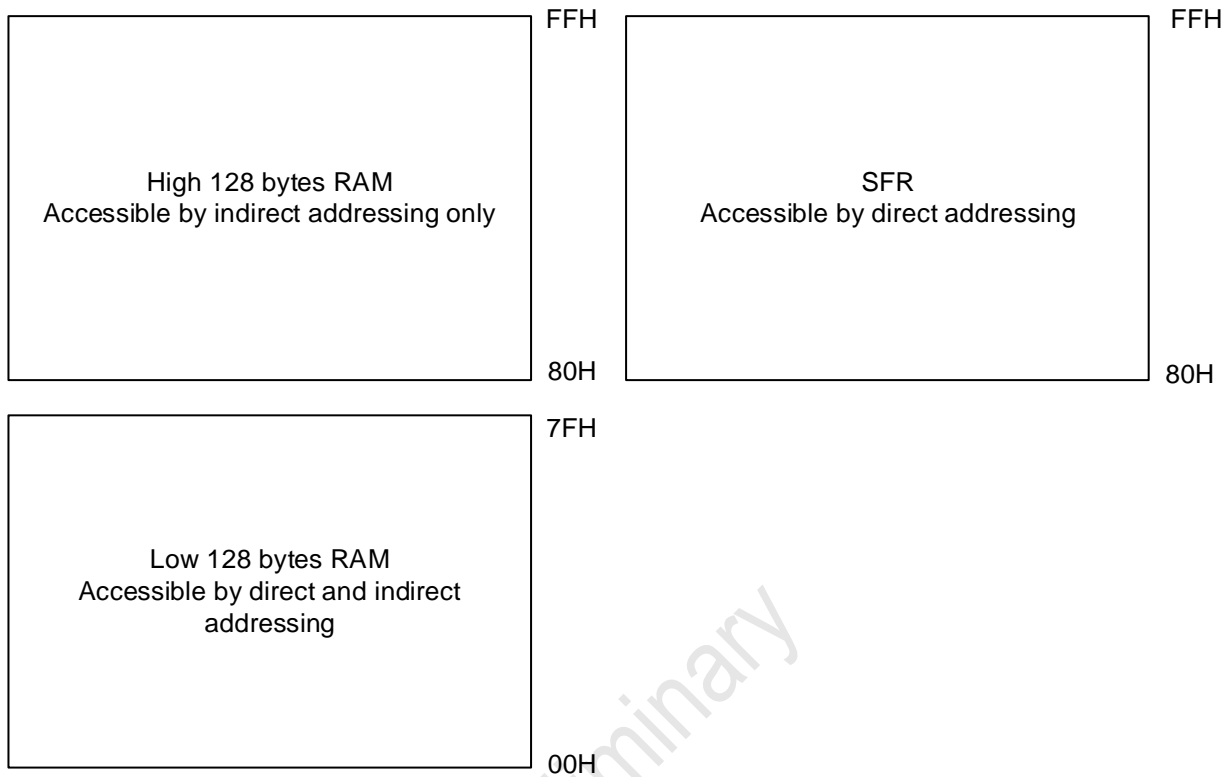

256 bytes RAM Structure Diagram

low 128 bytes RAM structure is shown below:

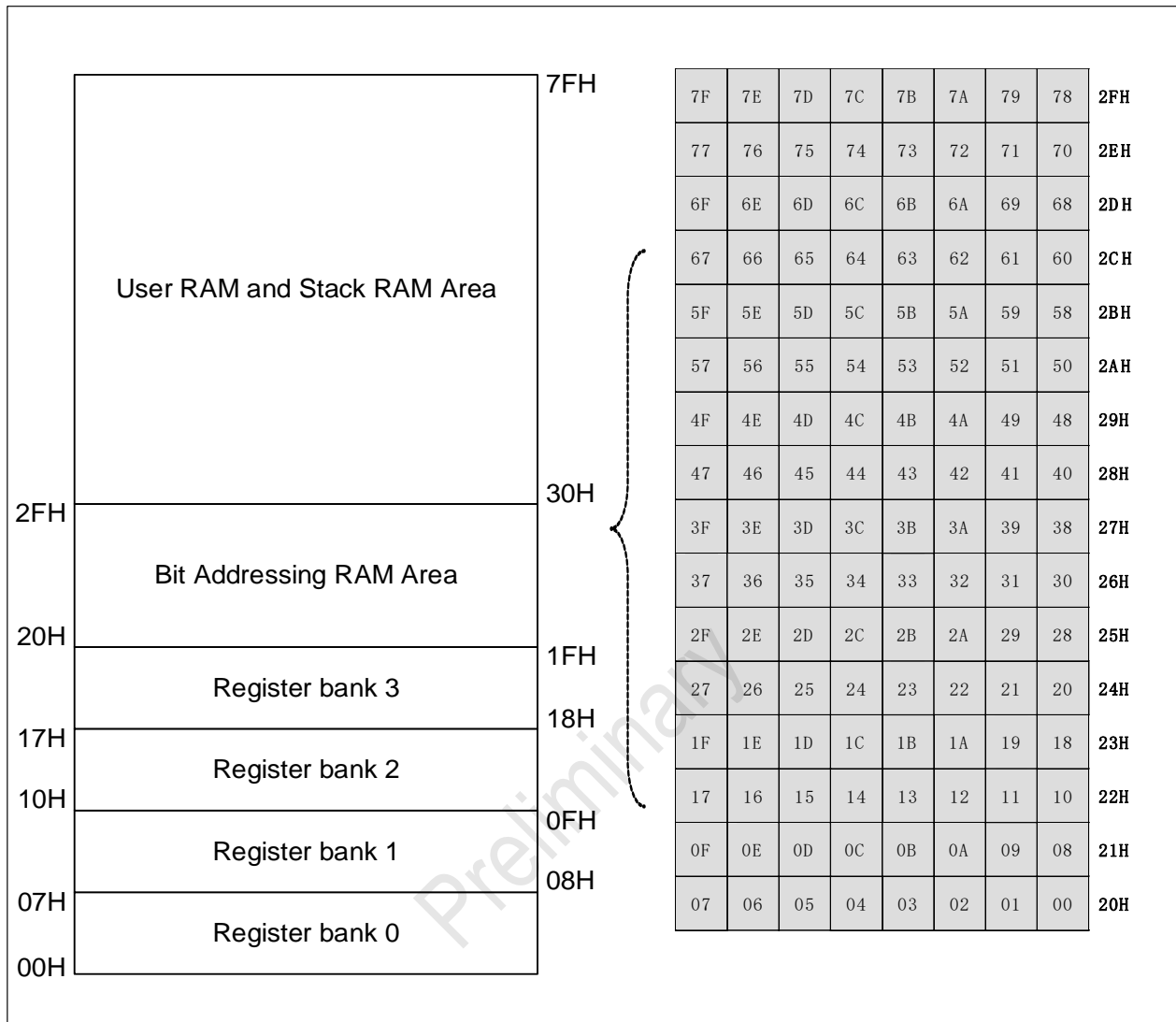

SRAM Structure Diagram

6 Special Function Register (SFR)

6.1 SFR Mapping

The SC92F735X provides some registers equipped with special functions, called SFR. The address of such SFRs is from 80H to FFH, some are bit-addressable, and others are not. It is very convenient for these bit-addressable registers to change the value of single bit, of which the address is end up with figure "0" or "8". All SFR shall use direct addressing for addressing.

The name and address of the SC92F735X special function registers are shown in the table below:

	0/8	1/9	2/A	3/B	4/C	5/D	6/E	7/F
F8h	-	-	-	-	-	-	OPINX	OPREG
F0h	B	IAPKEY	IAPADL	IAPADH	IAPADE	IAPDAT	IAPCTL	-

E8h	-	-	-	-	-	-	-	-
E0h	ACC	-	-	-	-	-	-	-
D8h	-	-	-	-	-	PWMDTY3	PWMDTY4	PWMDTY5
D0h	PSW	PWMCFG0	PWMCON	PWMPRD	PWMCFG1	PWMDTY0	PWMDTY1	PWMDTY2
C8h	T2CON	-	RCAP2L	RCAP2H	TL2	TH2	BTMCON	WDTCON
C0h	-	-	-	-	-	-	INT2F	INT2R
B8h	IP	IP1	INT0F	INT0R	-	-	-	-
B0h	-	-	-	-	-	-	-	-
A8h	IE	IE1	-	ADCCFG0	ADCCFG1	ADCCON	ADCVL	ADCVH
A0h	P2	P2CON	P2PH	-	-	-	-	-
98h	SCON	SBUF	P0CON	P0PH	P0VO	-	-	-
90h	P1	P1CON	P1PH	-	-	-	-	IOHCON
88h	TCON	TMOD	TL0	TL1	TH0	TH1	TMCON	OTCON
80h	P0	SP	DPL	DPH	-	-	-	PCON
	Bit Addressable	Not Bit Addressable						

Notes:

Hollow space of SFR refers to the fact that there is no such register RAM, it is not recommended for user to use.

6.2 SFR Instructions

For a description of each SFR, see the following table:

Register Name	Address	Description	7	6	5	4	3	2	1	0	Initial value
P0	80H	P0 Data Register	-	-	P05	P04	P03	P02	P01	P00	xx000000b
SP	81H	Stack Pointer	SP[7: 0]								00000111b
DPL	82H	Data Pointer Low byte of DPTR	DPL[7: 0]								00000000b
DPH	83H	Data Pointer High byte 噢发 DPTR	DPH[7: 0]								00000000b
PCON	87H	Power Management Control Register	SMOD	-	-	-	-	-	STOP	IDL	0xxxx00b
TCON	88H	Timer Control Register	TF1	TR1	TF0	TR0	-	-	-	-	0000xxxxb
TMOD	89H	Timer Operating Mode Register	-	C/T1	M11	M01	-	C/T0	M10	M00	x000x000b
TL0	8AH	Timer0 Low 8 bits	TL0[7: 0]								00000000b
TL1	8BH	Timer1 Low 8 bits	TL1[7: 0]								00000000b
TH0	8CH	Timer0 High 8 bits	TH0[7: 0]								00000000b
TH1	8DH	Timer1 High 8 bits	TH1[7: 0]								00000000b
TMCON	8EH	Timer Frequency Control Register	-	-	-	-	-	T2FD	T1FD	T0FD	xxxxx000b
OTCON	8FH	Output Control Register	-	-	-	-	VOIRS[1:0]		-	-	xxx00xxb
P1	90H	P1 Data Register	P17	P16	-	-	P13	P12	P11	P10	00xx0000b
P1CON	91H	P1 Input / Output Control Register	P1C7	P1C6	-	-	P1C3	P1C2	P1C1	P1C0	00xx0000b
P1PH	92H	P1 Pull-up Resistor Control Register	P1H7	P1H6	-	-	P1H3	P1H2	P1H1	P1H0	00xx0000b
IOHCON	97H	IOH Setup Register	P2H[1: 0]		P2L[1: 0]		P0H[1: 0]		P0L[1: 0]		00000000b

SCON	98H	Serial Control Register	SM0	SM1	SM2	REN	TB8	RB8	TI	RI	0000000b
SBUF	99H	serial data buffer	SBUF[7:0]								0000000b
P0CON	9AH	P0 Input / Output Control Register	-	-	P0C5	P0C4	P0C3	P0C2	P0C1	P0C0	xx00000b
P0PH	9BH	P0 Pull-up Resistor Control Register	-	-	P0H5	P0H4	P0H3	P0H2	P0H1	P0H0	xx00000b
P0VO	9CH	P0 Port LCD Voltage Output Register	-	-	-	P04VO	P03VO	P02VO	P01VO	P00VO	xxx0000b
P2	A0H	P2 Data Register	P27	P26	P25	P24	-	-	P21	P20	0000xx00b
P2CON	A1H	P2 Input / Output Control Register	P2C7	P2C6	P2C5	P2C4	-	-	P2C1	P2C0	0000xx00b
P2PH	A2H	P2 Pull-up Resistor Control Register	P2H7	P2H6	P2H5	P2H4	-	-	P2H1	P2H0	0000xx00b
IE	A8H	Interrupt Enable Register	EA	EADC	ET2	EUART	ET1	-	ET0	EINT0	0000x00b
IE1	A9H	Interrupt Enable Register 1	-	-	-	-	EINT2	EBTM	EPWM	-	xxxx000xb
ADCCFG0	ABH	ADC Configuration Register 0	EAIN7	EAIN6	EAIN5	EAIN4	-	-	EAIN1	EAIN0	0000xx00b
ADCCFG1	ACH	ADC Configuration Register 1	-	-	-	-	-	-	EAIN9	EAIN8	xxxxxx00b
ADCCON	ADH	ADC Control Register	ADCEN	ADCS	LOWSP	EOC/ADCIF	ADCIS[3: 0]				0000000b
ADCVL	AEH	ADC Result Register	ADCV[3: 0]				-	-	-	-	0000xxxxb
ADCVH	AFH	ADC Result Register	ADCV[11: 4]								0000000b
IP	B8H	Interrupt Priority Control Register	-	IPADC	IPT2	IPUART	IPT1	-	IPT0	IPINT0	x0000x00b
IP1	B9H	Interrupt Priority Control Register 1	-	-	-	-	IPINT2	IPBTM	IPPWM	-	xxxx000xb
INT0F	BAH	INT0 Falling Edge Interrupt Control Register	-	-	-	-	INT0F3	INT0F2	INT0F1	INT0F0	xxxx0000b

INT0R	BBH	INT0 Rising Edge Interrupt Control Register	-	-	-	-	INT0R3	INT0R2	INT0R1	INT0R0	xxxx0000b
INT2F	C6H	INT2 Falling Edge Interrupt Control Register	-	-	INT2F5	INT2F4	-	-	-	-	xx00xxxxb
INT2R	C7H	INT2 Rising Edge Interrupt Control Register	-	-	INT2R5	INT2R4	-	-	-	-	xx00xxxxb
T2CON	C8H	Timer2 Control Register	TF2	-	RCLK	TCLK	-	TR2	-	-	0x00x0xxb
RCAP2L	CAH	Timer2 Reload Low 8 bits	RCAP2L[7:0]								00000000b
RCAP2H	CBH	Timer2 Reload High 8 bits	RCAP2H[7:0]								00000000b
TL2	CCH	Timer2 Low 8 bits	TL2[7: 0]								00000000b
TH2	CDH	Timer2 High 8 bits	TH2[7: 0]								00000000b
BTMCON	CEH	Low-Frequency Timer Control Register	ENBTM	BTMIF	-	-	BTMFS[3: 0]				00xx0000b
WDTCON	CFH	WDT Control Register	-	-	-	CLRWDT	-	WDTCKS[2: 0]			xxx0x000b
PSW	D0H	Program Status Word Register	CY	AC	F0	RS1	RS0	OV	F1	P	00000000b
PWMCFG0	D1H	PWM Setup Register 0	-		INV2	INV1	INV0	ENPWM5	ENPWM4	ENPWM3	xx000000b
PWMCON	D2H	PWM Control Register	ENPWM	PWMIF	ENPWM2	ENPWM1	ENPWM0	PWMCKS[2:0]			00000000b
PWMPRD	D3H	PWM Period Setting Register	PWMPRD[7: 0]								00000000b
PWMCFG1	D4H	PWM Setting Register 1	-	-	INV5	INV4	INV3	-	-	-	xx000xxx b
PWMDTY0	D5H	PWM0 duty cycle setting register	PDT0[7: 0]								00000000b
PWMDTY1	D6H	PWM1 duty cycle setting register	PDT1[7: 0]								00000000b
PWMDTY2	D7H	PWM2 duty cycle setting register	PDT2[7: 0]								00000000b
PWMDTY3	DDH	PWM3 duty cycle setting register	PDT3[7:0]								00000000b

PWMDTY4	DEH	PWM4 duty cycle setting register	PDT4[7:0]				0000000b
PWMDTY5	DFH	PWM5 duty cycle setting register	PDT5[7:0]				0000000b
ACC	E0H	Accumulator	ACC[7:0]				0000000b
B	F0H	B Register	B[7:0]				0000000b
IAPKEY	F1H	IAP Protection Register	IAPKEY[7:0]				0000000b
IAPADL	F2H	IAP Address Low byte Register	IAPADR[7:0]				0000000b
IAPADH	F3H	IAP Address High byte Register	-	-	-	IAPADR[12:8]	xxx0000b
IAPADE	F4H	IAP Extended Address Register	IAPADER[7:0]				0000000b
IAPDAT	F5H	IAP Data Register	IAPDAT[7:0]				0000000b
IAPCTL	F6H	IAP Control Register	-	-	-	PAYTIMES[1:0] CMD[1:0]	xxxx0000b
OPINX	FEH	Option Pointer	OPINX[7:0]				0000000b
OPREG	FFH	Option Register	OPREG[7:0]				nnnnnnnb

6.2.1 Introduction to 8051 CPU Core Commonly-used Special function Registers

Program Counter (PC)

PC does not belong to SFR. 16-bit PC is the register used to control instruction execution sequence. After power-on or reset of microcontroller unit, PC value is 0000H, that is to say, the microcontroller unit is to execute program from 0000H.

Accumulator ACC (E0H)

Accumulator ACC is one of the commonly-used registers in 8051-based microcontroller unit, using A as mnemonic symbol in the instruction system. It is usually used to store operand and results for calculation or logical operations.

B Register (F0H)

B Register shall be used together with Accumulator A in multiplication and division operations. For example, instruction "MUL A, B" is used to multiply 8-bit unsigned numbers of Accumulator A and Register B. As for the acquired 16-bit product, low byte is placed in A and High byte in B. As for "DIV A, B" is used to divide A by B, place integer quotient in A and remainder in B. Register B can also be used as common temporary register.

Stack Pointer SP (81H)

Stack pointer is an 8-bit specialized register, it indicates the address of top stack in common RAM. After resetting of microcontroller unit, the initial value of SP is 07H, and the stack will increase from 08H. 08H ~ 1FH is address of register banks 1 ~ 3.

PSW (D0H) Program Status Word Register (Read/Write)

Bit Number	7	6	5	4	3	2	1	0
Bit Symbol	CY	AC	F0	RS1	RS0	OV	F1	P
R/W	R/W	R/W	R/W	R/W	R/W	R/W	R/W	R/W
POR	0	0	0	0	0	0	0	0

Bit Number	Bit Symbol	Description												
7	CY	Carry Flag bit 1: The top digit of add operation has carry bit or the top digit of subtraction operation has the borrow digit 0: The top digit of add operation has no carry bit or the top digit of subtraction operation has no borrow digit												
6	AC	Carry-bit auxiliary flag bit (adjustable upon BCD code add and subtraction operations) 1: There is carry bit in bit 3 upon add operation and borrow bit in bit 3 upon subtraction operation 0: No borrow bit and carry bit												
5	F0	User flag bit												
4 ~ 3	RS1,RS0	Register banks selection bits <table border="1" style="margin-left: 20px;"> <thead> <tr> <th>RS1</th> <th>RS0</th> <th>Current Selected Register banks 0 ~ 3</th> </tr> </thead> <tbody> <tr> <td>0</td> <td>0</td> <td>Group 0 (00H ~ 07H)</td> </tr> <tr> <td>0</td> <td>1</td> <td>Group 1 (08H ~ 0FH)</td> </tr> <tr> <td>1</td> <td>0</td> <td>Group 2 (10H ~ 17H)</td> </tr> </tbody> </table>	RS1	RS0	Current Selected Register banks 0 ~ 3	0	0	Group 0 (00H ~ 07H)	0	1	Group 1 (08H ~ 0FH)	1	0	Group 2 (10H ~ 17H)
RS1	RS0	Current Selected Register banks 0 ~ 3												
0	0	Group 0 (00H ~ 07H)												
0	1	Group 1 (08H ~ 0FH)												
1	0	Group 2 (10H ~ 17H)												

		1	1	Group 3 (18H ~ 1FH)
2	OV	Overflow flag bit		
1	F1	F1 flag bit User customized flag		
0	P	Parity flag bit. This flag bit is the parity value of the number of 1 in accumulator ACC. 1: Odd number of number of 1 in ACC 0: Even number of number of 1 in ACC (including 0)		

Data Pointer DPTR (82H, 83H)

The Data pointer DPTR is a 16-bit dedicated register, which is composed of Low byte DPL (82H) and High byte DPH (83H). DPTR is the only register in the traditional 8051-based MCU that can directly conduct 16-bit operation, which can also conduct operations on DPL and DPH by byte.

7 Power, Reset and Clock

7.1 Power Circuit

The SC92F735X Power includes circuits such as BG, LDO, POR and LVR, which are able to reliably work within the scope of 2.4V ~ 5.5V. Besides, a calibrated 2.4V voltage is built in the IC, which is used as ADC internal reference voltage. The user can search for specific configuration contents in [16 Analog-to-digital converter \(ADC\)](#).

7.2 Power-on Reset Process

After the SC92F735X power-on, the processes carried out before execution of client software are as follows:

- Reset stage
- Loading information stage
- Normal operation stage

7.2.1 Reset Stage

The SC92F735X will always be in reset mode. There will not be a valid clock until the voltage supplied to the SC92F735X is higher than certain voltage. The duration of reset stage is related to rising speed of external power. Once the external supply voltage is up to built-in POR voltage, the reset stage would be completed.

7.2.2 Loading Information Stage

There is a preheating counter inside the SC92F735X. During the reset stage, this preheating counter is always

reset as zero. After the voltage is higher than POR voltage, internal RC oscillator starts to oscillate and this preheating counter starts to count. When internal preheating counter counts up to certain number, one byte data will be read from IFB of Flash ROM (including Code Option) for every certain number of HRC clock, which is saved to internal system registers. After the preheating is completed, such reset signal will end.

7.2.3 Normal Operating Stage

After the loading information stage has been completed, the SC92F735X starts to read instruction code from Flash and enters normal operating stage. At this time, LVR voltage is the set value of Code Option written by user.

7.3 Reset Mode

The SC92F735X has 4 kinds of reset modes: ① External RST reset ② Low-voltage reset (LVR) ③ Power-on reset (POR) ④ WatchDog (WDT) reset.

7.3.1 External Reset

External reset is to supply a certain width reset pulse signal to the SC92F735X from the RST pin to realize the SC92F735X reset.

The RST/INT01/P1.1 can be used as RST (reset pin), when the SC92F735X power-on, the user can configure P1.1 as non-reset pin in Customer Option via PC programme software before programming.

7.3.2 Low-voltage Reset (LVR)

The SC92F735X provides a low-voltage reset circuit. There are 4-level LVR voltage options: 4.3V, 3.7V, 2.9V and 2.3V. The default is the Option value written by user.

OP_CTM0 (C1H@FFH) Customer Option Register 0 (Read/Write)

Bit Number	7	6	5	4	3	2	1	0
Bit Symbol	ENWDT	-	SCLKS[1: 0]		DISRST	DISLVR	LVRS[1: 0]	
R/W	R/W	-	R/W		R/W	R/W	R/W	
POR	n	x	n		n	n	n	

Bit Number	Bit Symbol	Description
2	DISLVR	LVR control bit 0: LVR valid 1: LVR invalid
1 ~ 0	LVRS [1: 0]	LVR voltage selection bits

		11: 4.3 V reset
		10: 3.7 V reset
		01: 2.9 V reset
		00: 2.3 V reset

The Circuit Diagram of the SC92F735X Resetting Part is shown below:

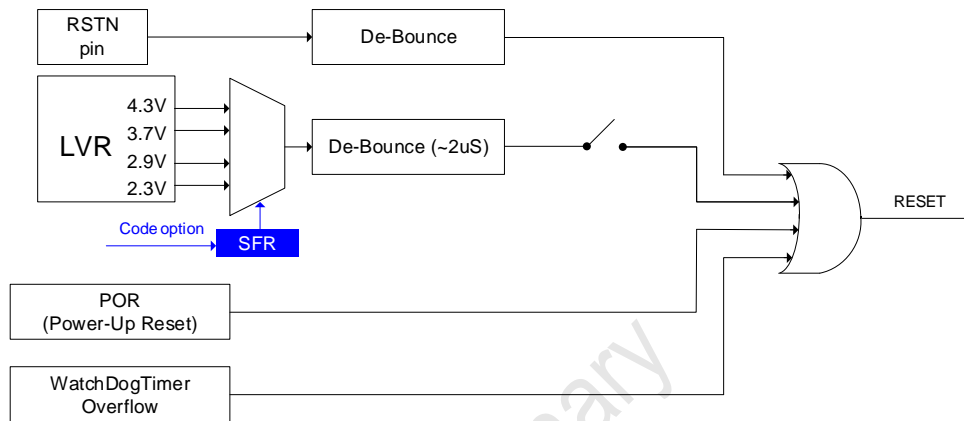

The SC92F735X Reset Circuit Diagram

7.3.3 Power-on Reset (POR)

The SC92F735X provides a power-on reset circuit. When power voltage V_{DD} is up to POR reset voltage, the system will be reset automatically.

7.3.4 WatchDog Reset (WDT)

The SC92F735X has a WDT, the clock source of which is the internal 128 kHz oscillator. User can select whether to enable WatchDog Reset function by programmer Code Option.

OP_CTM0 (C1H@FFH) Customer Option Register 0 (Read/Write)

Bit Number	7	6	5	4	3	2	1	0
Bit Symbol	ENWDT	-	SCLKS[1: 0]		DISRST	DISLVR	LVRs[1: 0]	
R/W	R/W	-	R/W		R/W	R/W	R/W	
POR	n	x	n		n	n	n	

Bit Number	Bit Symbol	Description
7	ENWDT	WDT control bit (This bit is transferred by the system to the value set by the user Code Option) 1: WDT valid 0: WDT invalid

WDTCON (CFH) WDT Control Register (Read/Write)

Bit Number	7	6	5	4	3	2	1	0
Bit Symbol	-	-	-	CLRWDT	-	WDTCKS[2: 0]		
R/W	-	-	-	R/W	-	R/W		
POR	x	x	x	0	x	0	0	0

Bit Number	Bit Symbol	Description												
4	CLRWDT	Clear WDT (Only valid when set to 1) 1: WDT counter restart, cleared by system hardware												
2 ~ 0	WDTCKS [2: 0]	WDT clock selection bits <table border="1"> <thead> <tr> <th>WDTCKS[2: 0]</th> <th>WDT overflow time</th> </tr> </thead> <tbody> <tr> <td>000</td> <td>500ms</td> </tr> <tr> <td>001</td> <td>250ms</td> </tr> <tr> <td>010</td> <td>125ms</td> </tr> <tr> <td>011</td> <td>62.5ms</td> </tr> <tr> <td>100</td> <td>31.5ms</td> </tr> </tbody> </table>	WDTCKS[2: 0]	WDT overflow time	000	500ms	001	250ms	010	125ms	011	62.5ms	100	31.5ms
WDTCKS[2: 0]	WDT overflow time													
000	500ms													
001	250ms													
010	125ms													
011	62.5ms													
100	31.5ms													

		101	15.75ms
		110	7.88ms
		111	3.94ms
7 ~ 5, 3	-	Reserved	

7.3.5 Reset Initial State

During reset, most registers are set to their initial values and the WDT remains disable. The initial value of stack pointer SP is 07h. Reset of “Hot Start” (such as WDT, LVR, etc.) will not influence SRAM which always keep the value before resetting. The SRAM contents will be retained until the power voltage is too low to keep RAM alive.

The initial value of power-on reset in SFRs is shown in the table below:

SFR Name	POR	SFR Name	POR
ACC	00000000b	P0PH	xx000000b
B	00000000b	P0VO	xxx00000b
PSW	00000000b	P1	00xx0000b
SP	00000111b	P1CON	00xx0000b
DPL	00000000b	P1PH	00xx0000b
DPH	00000000b	P2	0000xx00b
PCON	0xxxxx00b	P2CON	0000xx00b
ADCCFG0	0000xx00b	P2PH	0000xx00b
ADCCFG1	xxxxxx00b	PWMCFG0	xx000000b
ADCCON	00000000b	PWMCFG1	xx000xxx b
ADCVH	00000000b	PWMCON	00000000b
ADCVL	0000xxxxb	PWMDTY0	00000000b

BTMCON	00xx0000b	PWMDTY1	00000000b
IAPADE	00000000b	PWMDTY2	00000000b
IAPADH	xxx00000b	PWMDTY3	00000000b
IAPADL	00000000b	PWMDTY4	00000000b
IAPCTL	xxxx0000b	PWMDTY5	00000000b
IAPDAT	00000000b	PWMPRD	00000000b
IAPKEY	00000000b	RCAP2H	00000000b
IE	00000x00b	RCAP2L	00000000b
IE1	xxxx000xb	SBUF	00000000b
INT0R	xxxx0000b	SCON	00000000b
INT2R	xx00xxxxb	TCON	0000xxxxb
INT0F	xxxx0000b	TMCON	xxxxx000b
INT2F	xx00xxxxb	TMOD	x000x000b
IP	x0000x00b	TH0	00000000b
IP1	xxxx000xb	TL0	00000000b
OTCON	xxxx00xxb	TH1	00000000b
OPINX	00000000b	TL1	00000000b
OPREG	nnnnnnnnb	T2CON	0x00x0xxb
IOHCON	00000000b	TH2	00000000b

P0	xx000000b	TL2	00000000b
P0CON	xx000000b	WDTCN	xxx0x000b

7.4 High-speed RC Oscillator Circuit

The SC92F735X has a built-in adjustable high-precision HRC. HRC is precisely calibrated to 24 MHz@5V/25°C when delivery. The user can set system clock as 24/12/6/2MHz by programmer Code Option. The calibration process is to filter the influence of processing deviation on precision. There will be certain drifting of this HRC depending on operating temperature and voltage. As for voltage drifting (4.0V ~ 5.5V) and temperature drifting (-20°C ~ 85°C), the deviation is within $\pm 1\%$.

OP_CTM0 (C1H@FFH) Customer Option Register 0 (Read/Write)

Bit Number	7	6	5	4	3	2	1	0
Symbol	ENWDT	-	SCLKS[1: 0]		DISRST	DISLVR	LVRS[1: 0]	
R/W	R/W	-	R/W		R/W	R/W	R/W	
POR	n	X	n		n	n	n	

Bit Number	Bit Symbol	Description
5 ~ 4	SCLKS[1: 0]	System clock frequency selection bits: 00: reserved; System clock frequency is HRC frequency divided by 1, 01: system clock frequency is HRC frequency divided by 2; 10: system clock frequency is HRC frequency divided by 4; 11: system clock frequency is HRC frequency divided by 12;

The SC92F735X has a special function: the user can modify SFR value to adjust frequency of HRC within certain scope.

OP_HRCR (83h@FFH) System Clock Change Register (Read/Write)

Bit Number	7	6	5	4	3	2	1	0

Bit Symbol	OP_HRCR[7: 0]							
R/W	R/W							
POR	n	n	n	n	n	n	n	n

Bit Number	Bit Symbol	Description																		
7 ~ 0	OP_HRCR[7: 0]	<p>HRC frequency change register</p> <p>The value of OP_HRCR[7:0] after power-on guarantee HRC is 24/12/6/2MHz (according to the user's choice of Code Option). There may be difference in OP_HRCR[s] of each IC. The user can change the HRC operating frequency by modifying the value of this register.</p> <p>When initial value is OP_HRCR[s], IC system clock frequency f_{SYS} can set specifically as 24/12/6/2MHz. For each change of 1 for OP_HRCR [7: 0], the change of HRC frequency is about 0.23%@12MHz.</p> <p>The relationship between OP_HRCR [7: 0] and output frequency HRC is shown as follows:</p> <table border="1" data-bbox="614 1142 1444 2049"> <tr> <td>OP_HRCR [7:0]</td> <td>f_{SYS} actual output frequency (taking 12M as an example)</td> </tr> <tr> <td>OP_HRCR [s]-n</td> <td>$12000 \cdot (1 - 0.23\% \cdot n)$ kHz</td> </tr> <tr> <td>...</td> <td>....</td> </tr> <tr> <td>OP_HRCR [s]-2</td> <td>$12000 \cdot (1 - 0.23\% \cdot 2) = 11944.8$ kHz</td> </tr> <tr> <td>OP_HRCR [s]-1</td> <td>$16000 \cdot (1 - 0.23\% \cdot 1) = 11972.4$ kHz</td> </tr> <tr> <td>OP_HRCR [s]</td> <td>12000 kHz</td> </tr> <tr> <td>OP_HRCR [s]+1</td> <td>$12000 \cdot (1 + 0.23\% \cdot 1) = 12027.6$ kHz</td> </tr> <tr> <td>OP_HRCR [s]+2</td> <td>$12000 \cdot (1 + 0.23\% \cdot 2) = 12055.2$ kHz</td> </tr> <tr> <td>...</td> <td>...</td> </tr> </table>	OP_HRCR [7:0]	f_{SYS} actual output frequency (taking 12M as an example)	OP_HRCR [s]-n	$12000 \cdot (1 - 0.23\% \cdot n)$ kHz	OP_HRCR [s]-2	$12000 \cdot (1 - 0.23\% \cdot 2) = 11944.8$ kHz	OP_HRCR [s]-1	$16000 \cdot (1 - 0.23\% \cdot 1) = 11972.4$ kHz	OP_HRCR [s]	12000 kHz	OP_HRCR [s]+1	$12000 \cdot (1 + 0.23\% \cdot 1) = 12027.6$ kHz	OP_HRCR [s]+2	$12000 \cdot (1 + 0.23\% \cdot 2) = 12055.2$ kHz
OP_HRCR [7:0]	f_{SYS} actual output frequency (taking 12M as an example)																			
OP_HRCR [s]-n	$12000 \cdot (1 - 0.23\% \cdot n)$ kHz																			
...																			
OP_HRCR [s]-2	$12000 \cdot (1 - 0.23\% \cdot 2) = 11944.8$ kHz																			
OP_HRCR [s]-1	$16000 \cdot (1 - 0.23\% \cdot 1) = 11972.4$ kHz																			
OP_HRCR [s]	12000 kHz																			
OP_HRCR [s]+1	$12000 \cdot (1 + 0.23\% \cdot 1) = 12027.6$ kHz																			
OP_HRCR [s]+2	$12000 \cdot (1 + 0.23\% \cdot 2) = 12055.2$ kHz																			
...	...																			

		OP_HRCR [s]+n	12000*(1+0.23%*n)kHz
<p>Note:</p> <ol style="list-style-type: none"> 1. The value of OP_HRCR[7:0] after each power-on of the IC is the value of high-frequency oscillator frequency f_{HRC} closest to 24/12/6/2MHz; the user can modify the value of HRC after each power-on by means of EEPROM to make IC system clock frequency f_{SYS} work at the frequency the user needs. 2. To guarantee IC operating reliably, the maximum operating frequency of IC shall not exceed 24MHz; 3. The user shall confirm the change of HRC frequency will not influence other functions. 			

7.5 Low- frequency RC Oscillator and Low- frequency Clock Timer

The SC92F735X is equipped with a built-in 128 kHz RC oscillation circuit , which can be set as clock source of WDT and low-frequency clock timer Base Timer. Open Base Timer or enable WDT to start 128 kHz low frequency oscillator. This oscillator is directly connected to Base Timer , which can wake up CPU from STOP mode and generate interrupt.

BTMCON (CEH) Low-Frequency Timer Control Register (Read/Write)

Bit Number	7	6	5	4	3	2	1	0
Bit Symbol	ENBTM	BTMIF	-	-	BTMFS[3:0]			
R/W	R/W	R/W	-	-	R/W			
POR	0	0	x	x	0	0	0	0

Bit Number	Bit Symbol	Description
7	ENBTM	Low-frequency Base Timer start control bit 0: Base Timer not start 1: Base Timer start
6	BTMIF	Base Timer interrupt application flag bit

		When CPU receives Base Timer interrupt, this flag will be cleared automatically by hardware. The user can clear it by software.
3 ~ 0	BTMFS [3: 0]	<p>Low-frequency clock interrupt frequency selection bits</p> <p>0000: an interrupt is generated for every 15.625ms</p> <p>0001: an interrupt is generated for every 31.25ms</p> <p>0010: an interrupt is generated for every 62.5ms</p> <p>0011: an interrupt is generated for every 125ms</p> <p>0100: an interrupt is generated for every 0.25s</p> <p>0101: an interrupt is generated for every 0.5s</p> <p>0110: an interrupt is generated for every 1.0s</p> <p>0111: an interrupt is generated for every 2.0s</p> <p>1000: an interrupt is generated for every 4.0s</p> <p>others: Reserved</p>
5 ~ 4	-	Reserved

The diagram of the Base Timer is as follows:

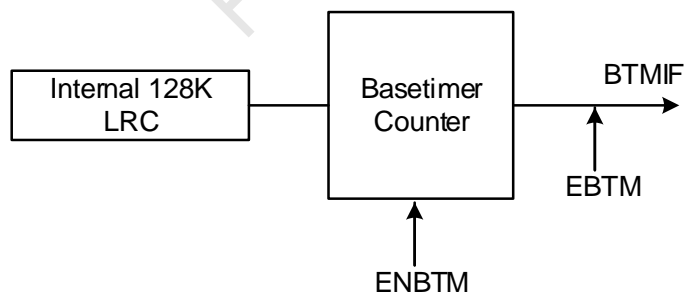

Base Timer Block

7.6 STOP Mode and IDLE Mode

The SC92F735X provides a SFR PCON, the user can configure bit 0 and bit 1 of this register to control MCU to enter different operating modes.

When PCON.1 = 1, internal high-frequency system clock would stop and system enter STOP mode, to save power. The system can be woken up from STOP by external interrupt INT0 , INT2, low-frequency clock interrupt, and external reset input.

When PCON.0 = 1, the programme would stop running and System enter IDLE mode. But the external equipment and clock will continue running, CPU will keep all states before entering IDLE mode. The system can

be woken up from IDLE by any interrupt.

PCON (87H) Power Management Control Register (only for write, *unreadable*)

Bit Number	7	6	5	4	3	2	1	0
Bit Symbol	SMOD	-	-	-	-	-	STOP	IDL
R/W	W	-	-	-	-	-	W	W
POR	0	x	x	x	x	x	0	0

Bit Number	Bit Symbol	Description
1	STOP	STOP mode control bit 0: normal operating mode 1: stop mode, high-frequency oscillator stops operating, low-frequency oscillator and WDT can select to work based on configuration
0	IDL	IDLE mode control bit 0: normal operating mode 1: IDLE mode, the program stops operating, but external equipment and clock continue to operate and all CPU states are saved before entering IDLE mode

Notes: When Configure MCU to enter STOP or IDLE mode, the instruction of configuring PCON register should be followed by 8 "NOP" instructions rather than other instructions. Or else, it will be unable to execute following instructions normally after wake-up!

For example, configure MCU to enter STOP mode:

C program example:

```
#include"intrins.h"

PCON |= 0x02;          //Set to 1 for PCON bit1 STOP bit, configure MCU to enter STOP mode

_nop_ ();             //At least 8 _nop_ () required

_nop_ ();

_nop_ ();

_nop_ ();
```

```
_nop_ ();  
_nop_ ();  
_nop_ ();  
_nop_ ();  
.....
```

Assembly program example:

```
ORL PCON, #02H      ; Set to 1 for PCON bits1 STOP bit, configure MCU to enter STOP mode  
NOP                 ; At least 8 NOP required  
NOP  
NOP  
NOP  
NOP  
NOP  
NOP  
NOP  
NOP  
.....
```

8 CPU and Function System

8.1 CPU

CPU used by the SC92F735X is the high-speed 1T standard 8051 core, whose instructions are completely compatible with traditional 8051 core microcontroller unit.

8.2 Addressing Mode

The addressing mode of the SC92F735X 1T 8051 CPU instructions includes: ① Immediate Addressing ② Direct Addressing ③ Indirect Address ④ Register Addressing ⑤ Relative Addressing ⑥ Indexed Addressing ⑦ Bit Addressing

8.2.1 Immediate Addressing

Immediate addressing is also called immediate operand addressing, which is the operand given to participate in operation in instruction, the instruction is illustrated as follows:

```
MOV A, #50H (This instruction is to move immediate operand 50H to Accumulator A)
```

8.2.2 Direct Addressing

In direct addressing mode, the instruction operand field indicates the address to participate in operation operand. Direct addressing can only be used to address SFRs, internal data registers and bit address space. The SFRs and bit address space can only be accessed by direct addressing. For example:

ANL 50H, #91H (The instruction indicates the data in 50H unit AND immediate operand 91H, and the results are stored in 50H unit. 50H refers to direct address, indicating one unit in internal data register RAM.)

8.2.3 Indirect Addressing

Indirect addressing is expressed as adding "@" before R0 or R1. Suppose the data in R1 is 40H and the data of internal data register 40H unit is 55H, then the instruction will be

```
MOV A, @R1 (Move the data 55h to Accumulator A).
```

8.2.4 Register Addressing

Register addressing is to operate the data in the selected registers R7 ~ R0, Accumulator A, general-purpose register B, address registers and carry bit C. The registers R7-R0 is indicated by lower 3 bits of instruction code. ACC, B, DPTR and carry bit C are implied in the instruction code. Therefore, register addressing can also include an implied addressing mode. The selection of register operating area depends on RS1 and RS0 of PSW. The registers indicated by instruction operand refers to the registers in current operating area.

```
INC R0    refers to (R0) +1→R0
```

8.2.5 Relative Addressing

Relative addressing is to add current value in program counter (PC) and the data in the second byte of the instruction, whose result shall be taken as the jump address of jump instruction. The Jump address is the target jump address, the current value in PC is the base address and the data in the second byte of the instruction is the offset address. Because the target jump address is relative to base address in PC, such addressing mode is called relative addressing. The offset is signed number, which ranges from +127 to -128, such addressing mode is mainly applied to jump instruction.

```
JC  $+50H
```

It indicates that if the carry bit C is 0, the contents in program counter PC remain the same, meaning no jump. On the contrary, if the carry bit C is 1, take the sum of the current value in PC and base address as well as offset 50H as the target jump address of this jump instruction.

8.2.6 Indexed Addressing

In indexed addressing mode, the instruction operand is to develop an indexed register to store indexed base address. Upon indexed addressing, the result by adding offset and indexed base address is taken as the address of operation operand. The indexed registers include PC and address register DPTR.

```
MOVC A, @A+DPTR
```

It indicates Accumulator A is used as offset register. Take the sum of the value in A and that in the address register DPTR as the address of operand. Then take the figure in the address out and transmit it to Accumulator A.

8.2.7 Bits Addressing

Bit addressing is a kind of addressing mode when conducting bit operation on internal data storage RAM and SFRs which are able to carry out bit operations. Upon bit operations, by taking carry bit C as bit operation accumulator, the instruction operand will give the address of this bit directly, then execute bit operation based on the nature of operation code.

```
MOV C, 20H (Transmit the bit operation register with address of 20H into carry bit C)
```

9 Interrupt

The SC92F735X provides 9 interrupt sources: Timer0, Timer1, Timer2, INT0, INT2, ADC, PWM, UART and Base Timer. These 9 interrupt sources are equipped with 2-level interrupt priority-capability and each interrupt source can be individually configured in high priority or low priority. As for two external interrupts, the triggering condition of each interrupt source can be set as rising edge, falling edge or dual-edge trigger. Each interrupt is equipped with independent priority setting bit, interrupt flag, interrupt vector and enable bit. Global interrupt enable bit EA can enable or disable all interrupts.

9.1 Interrupt Source and Vector

Lists for the SC92F735X interrupt source, interrupt vector and related control bit are shown below:

Interrupt Source	Interrupt condition	Interrupt Flag	Interrupt Enable Control	Interrupt Priority Control	Interrupt Vector	Query Priority	Interrupt Number (C51)	Flag Clear Mode	Capability of Waking up STOP
INT0	Compliant with External interrupt 0 conditions	-	EINT0	IPINT0	0003H	1 (high)	0	-	Yes
Timer0	Timer0 overflow	TF0	ET0	IPT0	000BH	2	1	H/W Auto	No
Timer1	Timer1 overflow	TF1	ET1	IPT1	001BH	3	3	H/W Auto	No
UART	Receiving or transmitting completed	RI/TI	EUART	IPUAR	0023H	4	4	Must be cleared by user	No
Timer2	Timer2 overflow	TF2	ET2	IPT2	002BH	5	5	Must be cleared by user	No
ADC	ADC conversion completed	ADCIF	EADC	IPADC	0033H	6	6	Must be cleared by user	No
PWM	PWM overflow	PWMIF	EPWM	IPPWM	0043H	7	8	H/W Auto	No
BTM	Base timer overflow	BTMIF	EBTM	IPBTM	004BH	8	9	H/W Auto	Yes
INT2	External interrupt 2 conditions compliant	-	EINT2	IPINT2	0053H	9	10	-	Yes

Under the circumstance where the master interrupt control bit EA and the respective interrupt control bit have been enable, the interrupt occurrence is shown below:

Timer Interrupt: Interrupt generates when Timer0 or Timer1 overflows and the interrupt flag TF0 or TF1 is set to "1". When the microcontroller unit responds to the timer interrupt, the interrupt flag TF0 or TF1 is reset automatically by hardware. Interrupt generates when Timer2 overflows and the interrupt flag TF2 is set to "1".

UART Interrupt: When UART receives or transmits a frame of data, RI or TI bit will be set to "1" automatically by hardware, UART Interrupt generates. Once UART interrupt generates, the hardware would not automatically clear RI/TI bit, which must be cleared by the user's software.

ADC Interrupt: After ADC conversion is completed, ADC interrupt generates, whose interrupt flag is the ADC conversion completion flag EOC/ADCIF (ADCCON.5). When user starts ADCS conversion, EOC will be reset automatically by hardware. Once conversion completes, EOC would be set to "1" automatically by hardware. User should clear the ADC interrupt flag by software when the interrupt service routine is executed after ADC interrupt generates.

PWM Interrupt: When PWM counter overflows (beyond PWMPD), The PWMIF bit will be set to 1 automatically by hardware, PWM interrupt generates. When the microcontroller unit executes PWM interrupt, the interrupt sign PWMIF will be clear to "0" automatically by hardware.

External Interrupt INT0, INT 2: When any external interrupt pin meets the interrupt conditions, external interrupt generates. There are 4 external interrupt sources for INT0 and 2 external interrupt sources for INT2, which can be set in rising edge, falling edge or dual edge interrupt trigger mode by setting SFRs (INTxF and INTxR). User can set the priority level of each interrupt through IP register. Besides, external interrupt INT0/ INT2 can also wake up STOP mode of microcontroller unit.

Preliminary

9.2 Interrupt Structure Diagram

The SC92F735X interrupt structure is shown in the figure below:

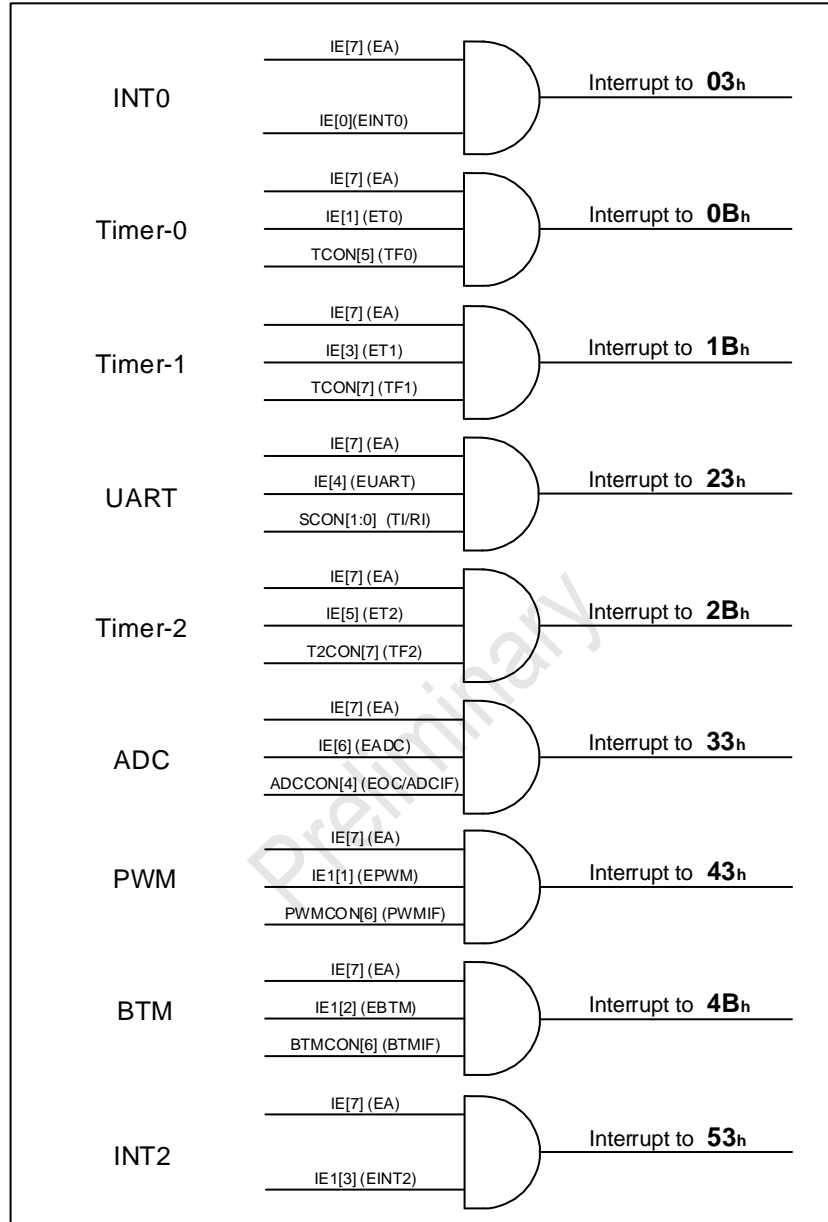

The SC92F735X Interrupt Structure and Vector

9.3 Interrupt Priority

The SC92F735X microcontroller unit has two-level interrupt priority capability. The interrupt requests of these interrupt sources can be programmed as high-priority interrupt or low-priority interrupt, which is to realize the nesting of two levels of interrupt service programs. One interrupt can be interrupted by a higher priority interrupt request when being responded to, which can not be interrupted by another interrupt request at the same priority level, until such response to the first-come interrupt ends up with the instruction "RETI". Exist the interrupt service routine and return to main program, the system would execute one more instruction before responding to new interrupt request.

That is to say:

- ① A lower priority interrupt can be interrupted by a higher priority interrupt request, but not vice versa;
- ② Any kind of interrupt being responded to can not be interrupted by another interrupt request at the same priority level.

Interrupt query sequence: As for the sequence of that the SC92F735X microcontroller unit responds to the same priority interrupts which occur in the meantime, the priority sequence of interrupt response shall be the same as the interrupt query number in C51, which is to preferentially respond to the interrupt with smaller query number then the interrupt with bigger query number.

9.4 Interrupt Processing Flow

When any interrupt generates and is responded by CPU, the operation of main program will be interrupted to carry out the following operations:

- ① Complete execution of instruction being currently executed;
- ② Push the PC value into stack for site protection;
- ③ Load Interrupt vector address into program counter (PC);
- ④ Carry out corresponding interrupt service program;
- ⑤ End Interrupt service program ends and execute RETI;
- ⑥ Pop PC value from stack and return to the program before responding to the interrupt.

During this process, the system will not immediately respond to other interrupts at the same priority level, but it will keep all interrupt requests having occurred and respond to new interrupt requests upon completing handling of the current interrupt.

9.5 Interrupt-related SFR Registers

IE (A8H) Interrupt Enable Register (Read/Write)

Bit Number	7	6	5	4	3	2	1	0
------------	---	---	---	---	---	---	---	---

Bit Symbol	EA	EADC	ET2	EUART	ET1	-	ET0	EINT0
R/W	R/W	R/W	R/W	R/W	R/W	-	R/W	R/W
POR	0	0	0	0	0	0	X	0

Bit Number	Bit Symbol	Description
7	EA	Global interrupt enable control bit 0: Disable all interrupts 1: Enable all interrupts
6	EADC	ADC interrupt enable control bit 0: Disable ADC interrupts 1: Interrupt is allowed upon completing ADC conversion
5	ET2	Timer2 interrupt enable control bit 0: Disable Timer2 interrupt 1: Enable Timer2 interrupt
4	EUART	UART interrupt enable control bit 0: Disable UART interrupt 1: Enable UART interrupt
3	ET1	Timer1 interrupt enable control bit 0: Disable Timer1 interrupt 1: Enable Timer1 interrupt
1	ET0	Timer0 interrupt enable control bit 0: Disable Timer0 interrupt 1: Enable Timer0 interrupt
0	EINT0	External interrupt 0 enable control bit

		0: Disable INT0 interrupt 1: Enable INT0 interrupt
2	-	Reserved

IP (B8H) Interrupt Priority Control Register (Read/Write)

Bit Number	7	6	5	4	3	2	1	0
Bit Symbol	-	IPADC	IPT2	IPUART	IPT1	-	IPT0	IPINT0
R/W	-	R/W	R/W	R/W	R/W	-	R/W	R/W
POR	x	0	0	0	0	X	0	0

Bit Number	Bit Symbol	Description
6	IPADC	ADC interrupt priority selection bit 0: ADC interrupt priority is low 1: ADC interrupt priority is high
5	IPT2	Timer2 interrupt priority selection bit 0: Timer2 interrupt priority is low 1: Timer2 interrupt priority is high
4	IPUART	UART interrupt priority selection bit 0: UART interrupt priority is low 1: UART interrupt priority is high
3	IPT1	Timer1 interrupt priority selection bit 0: Timer1 interrupt priority is low 1: Timer1 interrupt priority is high
1	IPT0	Timer 0 interrupt priority selection bit

		0: Timer0 interrupt priority is low 1: Timer0 interrupt priority is high
0	IPINT0	INT0 interrupt priority selection bit 0: INT0 interrupt priority is low 1: INT0 interrupt priority is high
7,2	-	Reserved

IE1 (A9H) Interrupt Enable Register 1 (Read/Write)

Bit Number	7	6	5	4	3	2	1	0
Bit Symbol	-	-	-	-	EINT2	EBTM	EPWM	-
R/W	-	-	-	-	R/W	R/W	R/W	-
POR	x	x	x	x	0	0	0	X

Bit Number	Bit Symbol	Description
3	EINT2	External interrupt 2 enabling control bit 0: Disable External interrupt 2 1: Enable External interrupt 2
2	EBTM	Base Timer interrupt enabling control bit 0: Disable Base Timer interrupt 1: Enable Base Timer interrupt
1	EPWM	PWM interrupt enabling control bit 0: Disable PWM interrupt 1: Enable interrupt upon PWM counting overflows (counting to PWMPRD)
7 ~ 4,0	-	Reserved

IP1 (B9H) Interrupt Priority Control Register 1 (Read/Write)

Bit Number	7	6	5	4	3	2	1	0
Bit Symbol	-	-	-	-	IPINT2	IPBTM	IPPWM	-
R/W	-	-	-	-	R/W	R/W	R/W	-
POR	x	x	x	x	0	0	0	x

Bit Number	Bit Symbol	Description
3	IPINT2	INT2 interrupt priority selection bit 0: INT2 interrupt priority is low 1: INT2 interrupt priority is high
2	IPBTM	Base Timer interrupt priority selection bit 0: Base Timer interrupt priority is low 1: Base Timer interrupt priority is high
1	IPPWM	PWM interrupt priority selection bit 0: PWM interrupt priority is low 1: PWM interrupt priority is high
7 ~ 4,0	-	Reserved

INT0F (BAH) INT0 Falling Edge Interrupt Control Register (Read/Write)

Bit Number	7	6	5	4	3	2	1	0
Bit Symbol	-	-	-	-	INT0F3	INT0F2	INT0F1	INT0F0
R/W	-	-	-	-	R/W	R/W	R/W	R/W
POR	x	x	x	x	0	0	0	0

Bit Number	Bit Symbol	Description
3 ~ 0	INT0Fn (n=0 ~ 3)	INT0 falling edge interrupt control bit 0: INT0n falling edge interrupt off 1: INT0n falling edge interrupt enabling
7 ~ 4	-	Reserved

INT0R (BBH) INT0 Rising Edge Interrupt Control Register (Read/Write)

Bit Number	7	6	5	4	3	2	1	0
Bit Symbol	-	-	-	-	INT0R3	INT0R2	INT0R1	INT0R0
R/W	-	-	-	-	R/W	R/W	R/W	R/W
POR	x	x	x	x	0	0	0	0

Bit Number	Bit Symbol	Description
3 ~ 0	INT0Rn (n=0 ~ 3)	INT0 rising edge interrupt control bit 0: INT0n rising edge interrupt off 1: INT0n rising edge interrupt enabling
7 ~ 4	-	Reserved

INT2F (C6H) INT2 Falling Edge Interrupt Control Register (Read/Write)

Bit Number	7	6	5	4	3	2	1	0
Bit Symbol	-	-	INT2F5	INT2F4	-	-	-	-
R/W	-	-	R/W	R/W	-	-	-	-

POR	x	x	0	0	x	x	x	x
-----	---	---	---	---	---	---	---	---

Bit Number	Bit Symbol	Description
5 ~ 4	INT2Fn (n=4 ~ 5)	INT2 falling edge interrupt control bit 0: INT2n falling edge interrupt off 1: INT2n falling edge interrupt enabling
7 ~ 6,3~0	-	Reserved

INT2R (C7H) INT2 Rising Edge Interrupt Control Register (Read/Write)

Bit Number	7	6	5	4	3	2	1	0
Bit Symbol	-	-	INT2R5	INT2R4	-	-	-	-
R/W	-	-	R/W	R/W	-	-	-	-
POR	x	x	0	0	x	x	x	x

Bit Number	Bit Symbol	Description
5 ~ 4	INT2Rn (n=4~ 5)	INT2 rising edge interrupt control bit 0: INT2n rising edge interrupt off 1: INT2n rising edge interrupt enabling
7 ~ 6,3~0	-	Reserved

10 Timer / Event Counter TIMER0 and TIMER1

The SC92F735X has two 16-bit Timer/Counters, Timer0 (T0) and Time1 (T1), with two operating modes: counter mode and timer mode. The operating modes selected by bit C/Tx in the SFR TMOD. T0 and T1 are essentially adding counters with different counting source. The source of timer generated from system clock or frequency division clock, but the source of counters is the input pulse to external pin. Only when TRx = 1, will T0 and T1 be enabled on for counting.

In counter mode, each input pulse on T0 and T1 pin of Timer/Counters will make the count value of T0 and T1 increase by 1 respectively.

In timer mode, users can select $f_{SYS}/12$ or f_{SYS} (f_{SYS} is the system clock after frequency division) as counting source of T0 and T1 by configuring SFR TMCON.

Timer/Counter T0 has 4 operating modes, and Timer/Counter T1 has 3 operating modes (Mode 3 does not exist):

- ① Mode 0: 13-bit Timer/Counter mode
- ② Mode 1: 16-bit Timer/Counter mode
- ③ Mode 2: 8-bit automatic reload mode
- ④ Mode 3: Two 8-bit timers/counters mode

In above modes, modes 0, 1 and 2 of T0 and T1 are the same, and mode 3 is different.

10.1 T0 and T1-related Special function Registers

Symbol	Address	Function	7	6	5	4	3	2	1	0	Reset Value
TCON	88H	Timer Control Register	TF1	TR1	TF0	TR0	-	-	-	-	0000xxxxb
TMOD	89H	Timer Operating Mode Register	-	C/T1	M11	M01	-	C/T0	M10	M00	x000x000b
TL0	8AH	Timer0 Low byte	TL0[7: 0]								00000000b
TL1	8BH	Timer1 Low byte	TL1[7: 0]								00000000b
TH0	8CH	Timer0 High byte	TH0[7: 0]								00000000b
TH1	8DH	Timer1 High byte	TH1[7: 0]								00000000b
TMCON	8EH	Timer Frequency Control Register	-	-	-	-	-	T2FD	T1FD	T0FD	xxxxx000b

Register instructions are shown below:

TCON (88H) Timer Control Register (Read/Write)

Bit Number	7	6	5	4	3	2	1	0
Bit	TF1	TR1	TF0	TR0	-	-	-	-

Mnemonic								
R/W	R/W	R/W	R/W	R/W	-	-	-	-
POR	0	0	0	0	x	x	x	x

Bit Number	Bit Mnemonic	Description
7	TF1	Timer1 overflow flag bit Set by hardware on Timer/Counter overflow. Cleared by hardware when the processor vectors to interrupt routine.
6	TR1	Timer1 run control bit Set/cleared by software to turn Timer/Counter on/off.
5	TF0	Timer0 overflow flag bit Set by hardware on Timer/Counter overflow. Cleared by hardware when the processor vectors to interrupt routine.
4	TR0	Timer0 run control bit Set/cleared by software to turn Timer/Counter on/off.
3~0	-	Reserved

TMOD (89H) Timer Operating Mode Register (Read/Write)

Bit Number	7	6	5	4	3	2	1	0
Bit Symbol	-	C/T1	M11	M01	-	C/T0	M10	M00
R/W	-	R/W	R/W	R/W	-	R/W	R/W	R/W
POR	x	0	0	0	x	0	0	0
	T1				T0			

Bit Number	Bit Symbol	Description																				
6	C/T1	Timer or Counter selector 1 0: Set for Timer operation (The source of T1 generated from frequency division clock) 1: Set for Counter operation (input from external pin T1/P1.3).																				
5 ~ 4	M11, M01	Timer/Counter 1 operating mode <table border="1"> <thead> <tr> <th>Mode</th> <th>M11</th> <th>M01</th> <th>Operation</th> </tr> </thead> <tbody> <tr> <td>0</td> <td>0</td> <td>0</td> <td>13-bit TIMER/Counter, TL1 high 3 bits invalid</td> </tr> <tr> <td>1</td> <td>0</td> <td>1</td> <td>16-bit Timer/Counter</td> </tr> <tr> <td>2</td> <td>1</td> <td>0</td> <td>8-bit Auto-Reload Mode. TH1 holds a value which is reloaded into 8-bit Timer/Counter TL1 each time it overflows.</td> </tr> <tr> <td>3</td> <td>1</td> <td>1</td> <td>Timer/Counter 1 is stopped</td> </tr> </tbody> </table>	Mode	M11	M01	Operation	0	0	0	13-bit TIMER/Counter, TL1 high 3 bits invalid	1	0	1	16-bit Timer/Counter	2	1	0	8-bit Auto-Reload Mode. TH1 holds a value which is reloaded into 8-bit Timer/Counter TL1 each time it overflows.	3	1	1	Timer/Counter 1 is stopped
Mode	M11	M01	Operation																			
0	0	0	13-bit TIMER/Counter, TL1 high 3 bits invalid																			
1	0	1	16-bit Timer/Counter																			
2	1	0	8-bit Auto-Reload Mode. TH1 holds a value which is reloaded into 8-bit Timer/Counter TL1 each time it overflows.																			
3	1	1	Timer/Counter 1 is stopped																			
2	C/T0	Timer or Counter selector 0 0: Cleared for Timer operation (input from internal system clock fsys). 1: Set for Counter operation (input from external pin T1/P1.2).																				
1 ~ 0	M10, M00	Timer0 operating mode <table border="1"> <thead> <tr> <th>Mode</th> <th>M10</th> <th>M00</th> <th>Operation</th> </tr> </thead> <tbody> <tr> <td>0</td> <td>0</td> <td>0</td> <td>13-bit TIMER/Counter, TL0 high 3 bits invalid</td> </tr> <tr> <td>1</td> <td>0</td> <td>1</td> <td>16-bit Timer/Counter</td> </tr> <tr> <td>2</td> <td>1</td> <td>0</td> <td>8-bit Auto-Reload Mode. TH0 holds a value which is reloaded into 8-</td> </tr> </tbody> </table>	Mode	M10	M00	Operation	0	0	0	13-bit TIMER/Counter, TL0 high 3 bits invalid	1	0	1	16-bit Timer/Counter	2	1	0	8-bit Auto-Reload Mode. TH0 holds a value which is reloaded into 8-				
Mode	M10	M00	Operation																			
0	0	0	13-bit TIMER/Counter, TL0 high 3 bits invalid																			
1	0	1	16-bit Timer/Counter																			
2	1	0	8-bit Auto-Reload Mode. TH0 holds a value which is reloaded into 8-																			

					bit Timer/Counter TL0 each time it overflows.
		3	1	1	Split Timer Mode. TL0 is an 8-bit Timer/Counter controlled by the standard Timer0 control bits. TH0 is only an 8-bit timer controlled by Timer1 control bits
7, 3	-	Reserved			

TMOD[0] ~ TMOD[2] of TMOD register is to set operating mode of T0; TMOD[4] ~ TMOD[6] is to set the operating mode of T1.

The function of timer and counter Tx is selected by the control bit C/Tx of SFR TMOD, and it's operating mode selected by M0x and M1x. Only when TRx, the switch of T0 and T1, is set to 1, will T0 and T1 be enabled

TMCON (8EH) Timer Frequency Control Register (Read/Write)

Bit Number	7	6	5	4	3	2	1	0
Bit Symbol	-	-	-	-	-	T2FD	T1FD	T0FD
R/W	-	-	-	-	-	R/W	R/W	R/W
POR	x	x	x	x	x	0	0	0

Bit Number	Bit Symbol	Description
1	T1FD	T1 input frequency selection control bit 0: T1 clock source is $f_{sys}/12$ 1: T1 clock source is f_{sys}
0	T0FD	T0 input frequency selection control bit 0: T0 clock source is $f_{sys}/12$ 1: T0 clock source is f_{sys}

IE (A8H) Interrupt Enable Register (Read/Write)

Bit Number	7	6	5	4	3	2	1	0
Bit Symbol	EA	EADC	ET2	EUART	ET1	-	ET0	EINT0
R/W	R/W	R/W	R/W	R/W	R/W	-	R/W	R/W
POR	0	0	0	0	0	x	0	0

Bit Number	Bit Symbol	Description
3	ET1	Timer1 interrupt enable control bit 0: Disable Timer1 interrupt 1: Enable Timer1 interrupt
1	ET0	Timer0 interrupt enable control bit 0: Disable Timer0 interrupt 1: Enable Timer0 interrupt

IP (B8H) Interrupt Priority Control Register (Read/Write)

Bit Number	7	6	5	4	3	2	1	0
Bit Symbol	-	IPADC	IPT2	IPSSI0	IPT1	-	IPT0	IPINT0
R/W	-	R/W	R/W	R/W	R/W	-	R/W	R/W
POR	x	0	0	0	0	0	0	0

Bit Number	Bit Symbol	Description
3	IPT1	Timer1 interrupt priority selection bit 0: Configure Timer1 interrupt priority as "low" 1: Configure Timer1 interrupt priority as "high"

1	IPT0	Timer0 interrupt priority selection bit 0: Configure Timer0 interrupt priority as “low” 1: Configure Timer0 interrupt priority as “high”
---	------	--

10.2 T0 Operating Mode

Timer0 can be configured in one of four operating modes by setting the bit pairs (M10, M00) in the TMOD[1] and TMOD[2] register.

Operating mode 0: 13-bit Timer/Counter

TH0 register is to store the high 8 bits (TH0.7 ~ TH0.0) of 13-bit Timer/Counter and TL0 is to store the low 5 bits (TL0.4 ~ TL0.0). The high three bits of TL0 (TL0.7 ~ TL0.5) are filled with uncertain values, they shall be omitted upon reading. When 13-bit Timer/Counter overflows with count increment, the system will set timer overflow flag TF0 to 1. An interrupt will be generated if the timer0 interrupt is enabled.

C/T0 bit selects the clock input source of Timer/Counter. If C/T0=1, the level fluctuation from high to low of Counter 0 input pin T0 (P1.2) will make Counter 0 data register add 1. If C/T0=0, the frequency division of system clock is the clock source of Timer0.

When TR0 = 1, Timer 0 is enabled. Setting TR0 would not reset the timer forcibly. It means that the timer register will start to count from the value of last clearing of TR0. Therefore, before enable the timer, it is required to configure the initial value of timer register.

When configured as a timer, the SFR T0FD is used to select fractional frequency ratio of clock source.

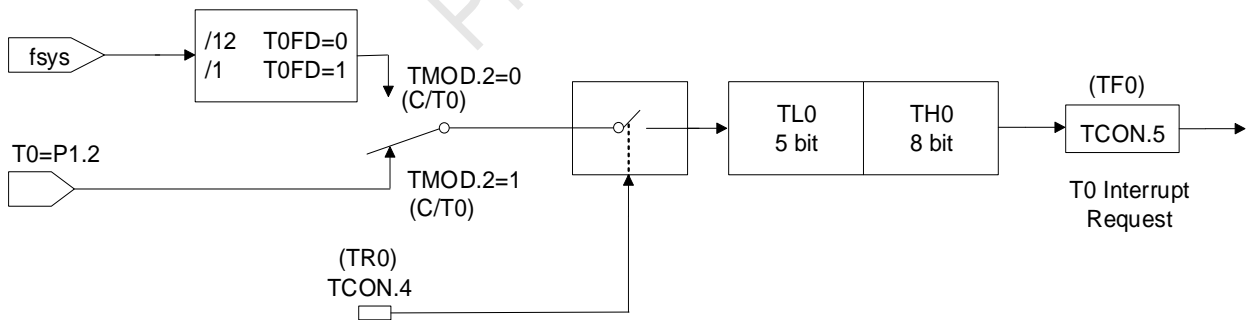

Operating mode 0: 13-bit Timer/Counter

Operating Mode 1: 16 Counter/Timer

Except for using 16 bits of (valid for all 8 bits of TL0) Timer/Counter, in mode 1 and mode 0, the operating mode, opening and configuration method are the same.

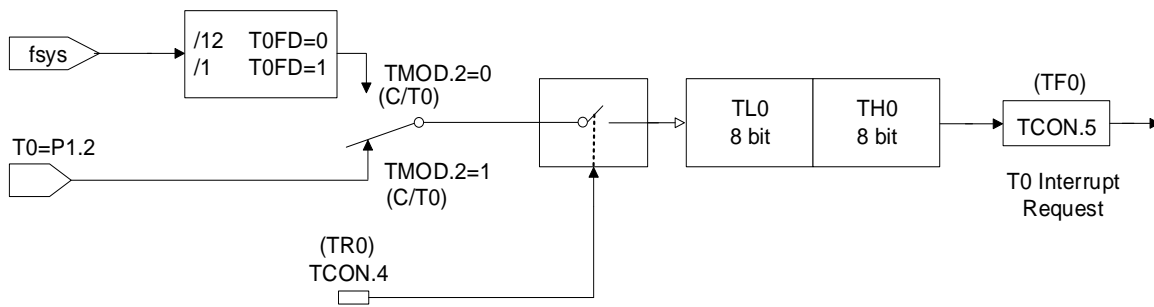

Operating mode 1: 16-bit Timer/Counter

Operating Mode 2: 8 Automatic Reload Counter/Timer

In operating mode 2, Timer0 is 8-bit automatic reload Timer/Counter. TL0 is to store counting value and TH0 is to store the reload value. When the counter in TL0 overflows and turn to 0x00, the overflow flag of Timer TF0 will be set to 1, and the data in register TH0 will be reloaded into register TL0. If the timer interrupt enabled, setting TF0 to 1 will generate an interrupt, but the reloaded value in TH0 will remain the same. Before starting the Timer to count correctly, TL0 shall be initialized to the required value.

Except for automatic reloaded function, the enabling and configuration mode of Timer/Counter in operating mode 2 shall be the same as that in mode 0 and mode 1.

When configured as a timer, the SFR TMCON bit 0 (T0FD) is used to select fractional frequency ratio of system clock f_{sys} .

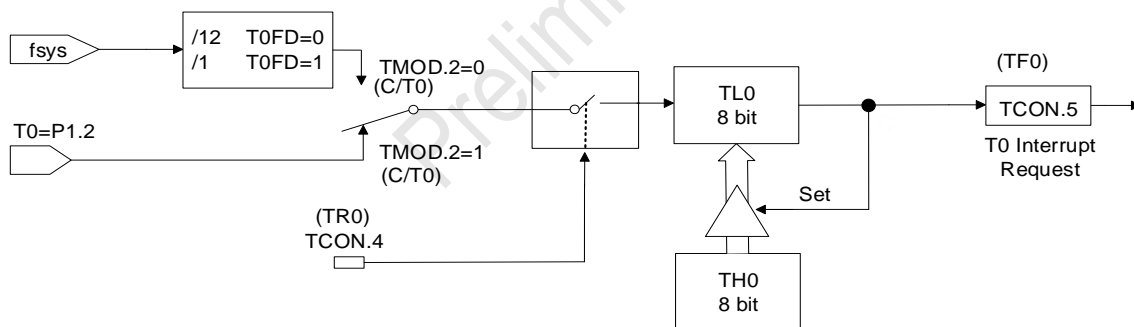

Operating Mode 2: 8 Automatic Reload Counter/Timer

Operating Mode 3: Two 8-bit Counter/Timer (only for Timer0)

In operating mode 3, Timer0 is used as two independent 8-bit Timer/Counters, respectively controlled by TL0 and TH0. TL0 is controlled by control bit (in TCON) and status bit (in TMOD) of Timer0 (TR0), C/T0, TF0. Timer0 is selected as Timer or Counter by TMOD bit 2 (C/T0).

TH0 is only limited to in Timer Mode, which is unable to configure as a Counter by TMOD.2 (C/T0). TH0 is enabled by set the timer control bit TR1 to 1. When overflow occurs and interrupt is discovered, set TF1 to 1 and proceed the interrupt as T1 interrupt.

When T0 is configured in Operating Mode 3, TH0 Timer occupies T1 interrupt resources and TCON register and the 16-bit counter of T1 will stop counting, equivalently "TR1=0". When adopting TH0 timer, it is required to configure TR1=1.

10.3 T1 Operating Mode

Timer1 can be configured in one of three operating modes by setting the bit pairs (M11, M01) in the TMOD register.

Operating mode 0: 13-bit Timer/Counter

TH1 register is to store high 8-bit (TH1.7 ~ TH1.0) of 13-bit Timer/Counter and TL1 is to store low 5-bit (TL1.4 ~ TL1.0). The high 3-bit of TL1 (TL1.7 ~ TL1.5) are uncertain values, they shall be omitted upon reading. When 13-bit Timer/Counter overflow with count increment, the system will set timer overflow flag TF1 as 1. An interrupt will be generated if the timer1 interrupt is enabled. C/T1 bit selects the clock input source of Timer/Counter.

If C/T1=1, the level fluctuation from high to low of timer1 input pin T1(P1.3) will make timer1 data register add 1. If C/T1=0, the frequency division of system clock is the clock source of timer1.

When TR1 is set to 1 and the timer is enabled. Setting TR1 does not force to reset timer counters, it means, if set TR1 to 1, the timer register will start to count from the value of last clearing of TR1. Therefore, before allowing timer, it is required to configure the initial value of timer register.

When configured as timer, the SFR T1FD is used to select fractional frequency ratio of clock source.

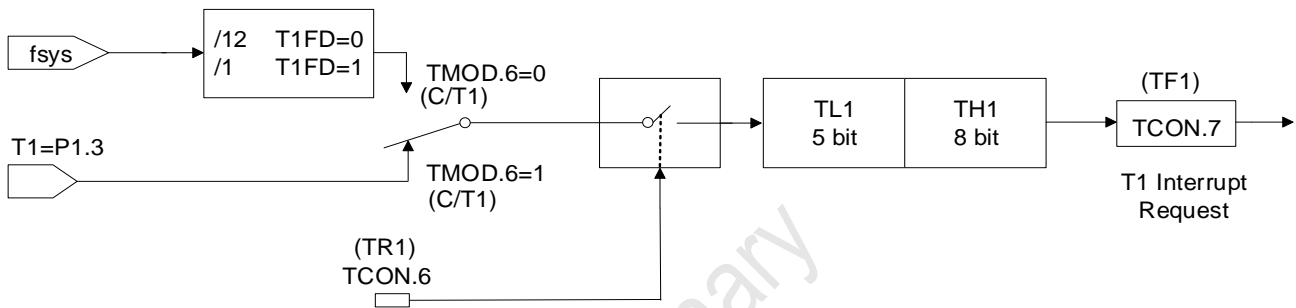

Operating mode 0: 13-bit Timer/Counter

Operating Mode 1: 16 Counter/Timer

Except for using 16-bit (valid for 8-bit data of TL1) Timer/Counter, the operating mode of mode 1 and mode 0 is the same. And the opening and configuration mode of both are also the same.

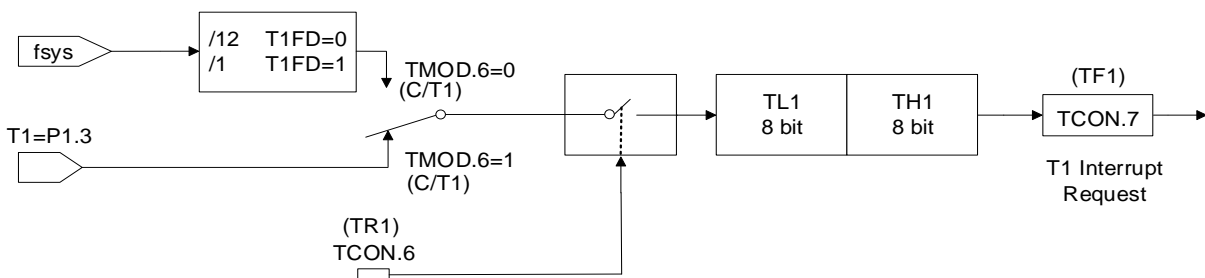

Operating mode 1: 16-bit Timer/Counter

Operating Mode 2: 8 Automatic Reload Counter/Timer

In operating mode 2, Timer1 is 8-bit automatic reload Timer/Counter. TL1 is to store counting value and TH1 is to store the reload value. When the counter in TL1 overflows 0x00, the overflow flag of Timer TF1 will be set to 1, and the value of register TH1 will be reloaded into register TL1. If enable the timer interrupt, setting TF1 to 1 will generate an interrupt, but the reloaded value in TH1 will remain unchanged. Before allowing Timer to correctly count, TL1 shall be initialized to the required value.

Except for automatic reloaded function, the enabling and configuration mode of Timer/Counter in operating mode 2 shall be the same as that of mode 0 and mode 1.

When configured as timer, the SFR TMCON bit 4 (T1FD) is used to select the ratio of clock source of timer to

fractional frequency of system clock f_{sys} .

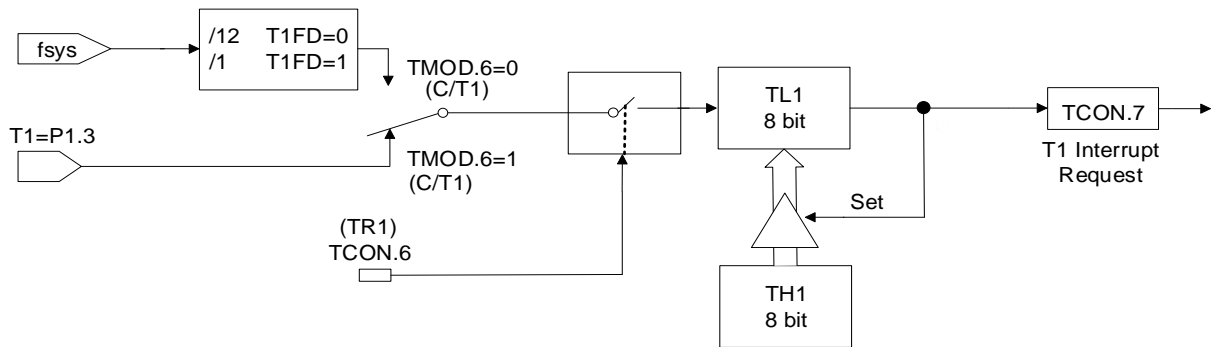

Operating Mode 2: 8 Automatic Reload Counter/Timer

Preliminary

11 Timer Counter Timer2

The Timer 2 in SC92F735X is essentially an addition counter. The clock source of Timer2 is system clock or its frequency division clock. TR2 is the switch control of T2 counting. T2 will be turned on for counting only when TR2 = 1.

In timer mode, users can select $f_{SYS}/12$ or f_{SYS} as counting source of T2 by configuring SFR TMCON.

Timer2 has 2 operating modes:

- ① Mode 1: 16-bit automatic reload timer mode
- ② Mode 2: Baud rate generator mode

11.1 T2-related SFR

Symbol	Address	Description	7	6	5	4	3	2	1	0	Reset Value
T2CON	C8H	Timer2 Control Register	TF2	-	RCLK	TCLK	-	TR2	-	-	0x00x0xxb
RCAP2L	CAH	Timer2 Reload Low 8 Byte	RCAP2L[7: 0]								0000000b
RCAP2H	CBH	Timer2 Reload High 8 Byte	RCAP2H[7: 0]								0000000b
TL2	CCH	Timer2 Low Byte	TL2[7: 0]								0000000b
TH2	CDH	Timer2 High Byte	TH2[7: 0]								0000000b
TMCON	8EH	Timer Frequency Control Register	-	-	-	-	-	T2FD	T1FD	T0FD	xxxxx000b

Register instructions are shown below:

T2CON (C8H) Timer2 Control Register (Read/Write)

Bit Number	7	6	5	4	3	2	1	0
Bit Symbol	TF2	-	RCLK	TCLK	-	TR2	-	-
R/W	R/W	-	R/W	R/W	-	R/W	-	-

POR	0	x	0	0	x	0	x	x
-----	---	---	---	---	---	---	---	---

Bit Number	Bit Symbol	Description
7	TF2	Timer2 overflow flag bit 0: No overflow (must be cleared by software) 1: Overflow (if RCLK=0 and TCLK=0, set to 1 by hardware)
5	RCLK	UART receive clock control bit 0: Timer1 generate receive baud rate 1: Timer2 generate receive baud rate
4	TCLK	UART transmit clock control bit 0: Timer1 generate transmit baud rate 1: Timer2 generate transmit baud rate
2	TR2	Timer2 start/stop control bit 0: Stop Timer2 1: Start Timer2
6,3,1 ~ 0	-	Reserved

TMCON (8EH) Timer Frequency Control Register (Read/Write)

Bit Number	7	6	5	4	3	2	1	0
Bit Symbol	-	-	-	-	-	T2FD	T1FD	T0FD
R/W	-	-	-	-	-	R/W	R/W	R/W
POR	x	x	x	x	x	0	0	0

Bit Number	Bit Symbol	Description
2	T2FD	T2 input frequency selection control bit 0: T2 clock source is $f_{sys}/12$ 1: T2 clock source is f_{sys}

IE (A8H) Interrupt Enable Register (Read/Write)

Bit Number	7	6	5	4	3	2	1	0
Bit Symbol	EA	EADC	ET2	EUART	ET1	-	ET0	EINT0
R/W	R/W	R/W	R/W	R/W	R/W	-	R/W	R/W
POR	0	0	0	0	0	x	0	0

Bit Number	Bit Symbol	Description
5	ET2	Timer2 interrupt enable control bit 0: Disable TIMER2 interrupt 1: Enable TIMER2 interrupt

IP (B8H) Interrupt Priority Control Register (Read/Write)

Bit Number	7	6	5	4	3	2	1	0
Bit Symbol	-	IPADC	IPT2	IPUART	IPT1	-	IPT0	IPINT0
R/W	-	R/W	R/W	R/W	R/W	-	R/W	R/W
POR	x	0	0	0	0	x	0	0

Bit Number	Bit Symbol	Description
------------	------------	-------------

5	IPT2	Timer2 interrupt priority selection bit 0: Configure Timer2 interrupt priority as “low” 1: Configure Timer2 interrupt priority as “high”
---	------	--

11.2 T2 Operating Mode

The operating mode and configuration mode of Timer2 are shown in the table below:

TR2	RCLK	TCLK	方式	
1	0	0	1	16-bit automatic reload timer
1	1	X	2	Baud rate generator
	X	1		
0	X	X	X	Timer2 stop

Operating Mode 1: 16-bit automatic Reload Timer

In the 16-bit automatic reload timer mode, T2 is incremented to 0xffffh and set to TF2 bit after overflow. At the same time, T2 loads the 16 bit values of registers RCAP2H and RCAP2L, which written by software, into TH2 and TL2 registers automatically.

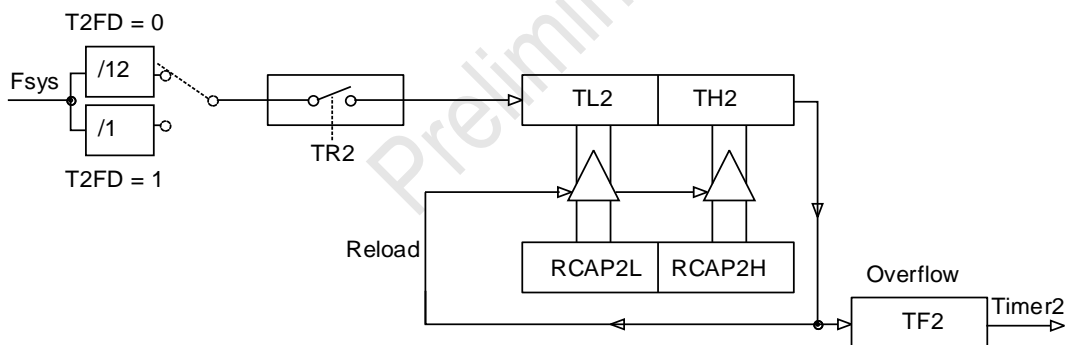

Operating Mode 1: 16-bit automatic Reload Timer

Operating Mode 2: Baud rate Generator

Timer 2 is selected as the baud rate generator by setting TCLK or/and RCLK in T2CON register. The baud rate of the receiver and transmitter can be different. If T2 is used as receiver or transmitter, T1 is used for another baud rate generator.

Set TCLK and/or RCLK in T2CON register to make T2 enter baud rate generator mode, which is similar to automatic reload mode.

The overflow of timer 2 will reload the values in the RCAP2H and RCAP2L registers into timer 2, but that will not generate interrupt.

The baud rate in UART mode 1 and 3 is determined by the overflow rate of timer 2, calculated from the following formula:

$$\text{BaudRate} = \frac{1}{16} \times \frac{fn2}{(65536 - [\text{RCAP2H}, \text{RCAP2L}] \times 2)}$$

fn2 is the clock frequency of timer 2:

$$fn2 = \frac{f_{sys}}{12}; \quad T2FD = 0$$

$$fn2 = f_{sys}; \quad T2FD = 1$$

The schematic diagram of timer 2 as baud rate generator is as follows:

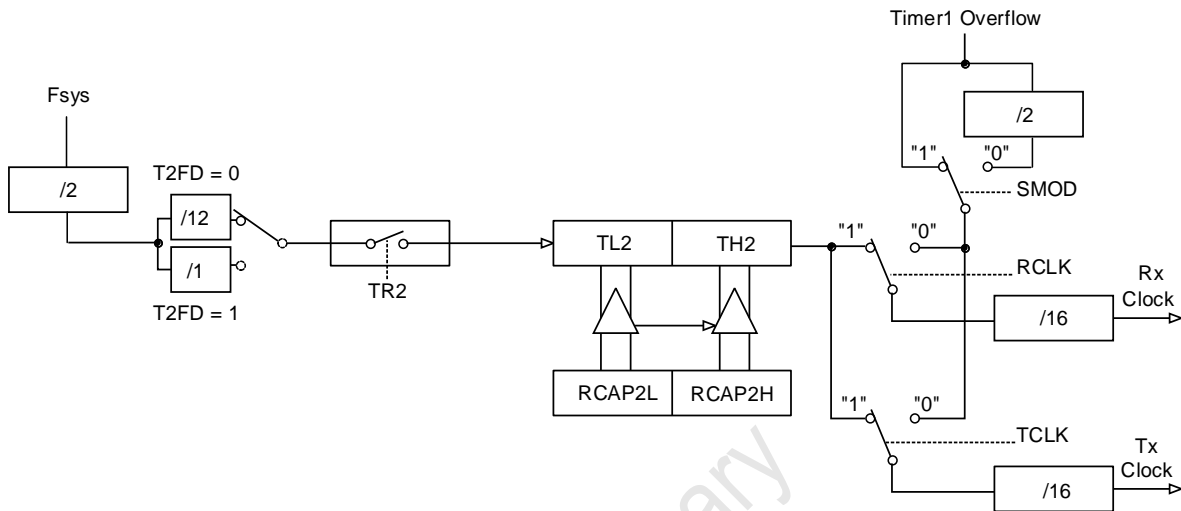

Operating Mode 2: Baud Rate Generator

Note:

1. When the event occurs or at any other time, the software can set TF2 to 1. Only software or hardware reset can clear it
2. When $EA = 1$ and $ET2 = 1$, setting up TF2 to 1 can arouse interrupt of Timer2;
3. When timer 2 is used as baud rate generator, writing TH2/TL2 or RCAP2H/RCAP2L will affect baud rate accuracy and raise communication error.

12.2 PWM-related SFR Registers

Symbol	Address	Description	7	6	5	4	3	2	1	0	Reset Value
PWMCFG0	D1H	PWMSetting Register0	-	-	INV2	INV1	INV0	ENPWM5	ENPWM4	ENPWM3	xx00000b
PWMCON	D2H	PWM Control Register	ENPWM	PWMIF	ENPWM2	ENPWM1	ENPWM0	PWMCKS[2:0]			0000000b
PWMPRD	D3H	PWM Cycle Setting Register	PWMPRD[7:0]								0000000b
PWMCFG1	D4H	PWM Setting Register1	-	-	INV5	INV4	INV3	-	-	-	xx000xxb
PWMDTY0	D5H	PWM0 Duty Setting Register	PDT0[7:0]								0000000b
PWMDTY1	D6H	PWM1 Duty Setting Register	PDT1[7:0]								0000000b
PWMDTY2	D7H	PWM2 Duty Setting Register	PDT2[7:0]								0000000b
PWMDTY3	DDH	PWM3 Duty Setting Register	PDT3[7:0]								0000000b
PWMDTY4	DEH	PWM4 Duty Setting Register	PDT4[7:0]								0000000b
PWMDTY5	DFH	PWM5 Duty Setting Register	PDT5[7:0]								0000000b
IE1	A9H	Interrupt Enable Register	-	-	-	-	EINT2	EBTM	EPWM	-	xxxx000xb
IP1	B9H	Interrupt priority control register	-	-	-	-	IPINT2	IPBTM	IPPWM	-	xxxx000xb

PWMCON (D2H) PWM Control Register (Read/Write)

Bit Number	7	6	5	4	3	2	1	0
Bit Symbol	ENPWM	PWMIF	ENPWM2	ENPWM1	ENPWM0	PWMCKS[2:0]		

R/W	R/W	R/W	R/W	R/W	R/W	R/W		
POR	0	0	0	0	0	0	0	0

Bit Number	Bit Symbol	Description
7	ENPWM	<p>PWM module switch control bit (Enable PWM)</p> <p>1: Enable Clock to enter PWM unit and PWM starts to work</p> <p>0: PWM unit stops operating and PWM counter resets to zero. PWMn still connects to output pin. If using other functions multiplexed with PWMn output pin, set ENPWMn to 0</p>
6	PWMIF	<p>PWM interrupt flag</p> <p>When PWM counter overflows (that is to say, the figure exceeds PWMPRD), this bit will be automatically set to 1 by hardware. If at this time IE1[1] (EPWM) is set to 1 as well, PWM interrupt generates.</p> <p>The hardware would not automatically clear this bit after the PWM interrupt generates, which must be cleared by the user's software.</p>
5	ENPWM2	<p>PWM2 functional switch control bit</p> <p>0: PWM2 do not output to IO</p> <p>1: PWM2 output to IO</p>
4	ENPWM1	<p>PWM1 functional switch control bit</p> <p>0: PWM1 do not output to IO</p> <p>1: PWM1 output to IO</p>
3	ENPWM0	<p>PWM0 functional switch control bit</p> <p>0: PWM0 do not output to IO</p> <p>1: PWM0 output to IO</p>
2~0	PWMCK[S[2:0]]	<p>PWM Clock Source Selector</p> <p>000: f_{sys}</p> <p>001: f_{sys}/2</p> <p>010: f_{sys}/4</p> <p>011: f_{sys}/8</p> <p>100: f_{sys}/32</p>

		101: $f_{SYS}/64$ 110: $f_{SYS}/128$ 111: $f_{SYS}/256$
--	--	---

PWMPRD[7:0] is a sharing cycle setting controller for six-channel PWM. Once the PWM counter counting to the preset value of PWMPRD[7:0], the counter will hop to 00h when the next PWM CLK comes, that is to say, the cycle of PWM0~5 is $(PWMPRD[7:0] + 1) * PWM$ clock.

The counting time of PWM counter can be controlled by PWMCKS[2:0]. Different number of system clocks can be selected to count one unit (pre-scalar selector), that is select the divider ratio of PWM counter clock source to system clock f_{SYS} . PWM0 ~ 5 can also be used by PWMCFG INV0~INV5 to select whether or not the PWM output is reversed.

PWMPRD (D3H) PWM Period Configuration Register (Read/Write)

Bit Number	7	6	5	4	3	2	1	0
Bit Symbol	PWMPRD[7:0]							
R/W	R/W	R/W	R/W	R/W	R/W	R/W	R/W	R/W
POR	0	0	0	0	0	0	0	0

Bit Number	Bit Symbol	Description
7~0	PWMPRD[7:0]	The Sharing Cycle Settings Of PWM0 ~ 5; This value represents the (period - 1) of the output waveform of PWM0~PWM5; That is to say, the period value of PWM output is $(PWMPRD[7:0] + 1) * PWM$ clock;

PWMCFG0 (D1H) PWM Configuration Register 0(Read/Write)

Bit Number	7	6	5	4	3	2	1	0
Bit Symbol	-	-	INV2	INV1	INV0	ENPWM5	ENPWM4	ENPWM3
R/W	-	-	R/W	R/W	R/W	R/W	R/W	R/W
POR	x	x	0	0	0	0	0	0

Bit Number	Bit Symbol	Description
5	INV2	PWM2 output reverse control bit 0: PWM2 output not invert 1: PWM2 output reverse
4	INV1	PWM1 output reverse control bit 0: PWM1 output not invert 1: PWM1 output reverse
3	INV0	PWM0 output reverse control bit 0: PWM0 output not invert 1: PWM0 output reverse
2	ENPWM5	PWM5 functional switch control bit 0: PWM5 do not output to IO 1: PWM5 output to IO
1	ENPWM4	PWM4 functional switch control bit 0: PWM4 do not output to IO 1: PWM4 output to IO
0	ENPWM3	PWM3 functional switch control bit 0: PWM3 do not output to IO 1: PWM3 output to IO
7~6	-	Reserve

PWMCFG1 (D4H) PWM Configuration Register (Read/Write)

Bit Number	7	6	5	4	3	2	1	0
Bit Symbol	-	-	INV5	INV4	INV3	-	-	-

R/W	-	-	R/W	R/W	R/W	-	-	-
POR	x	x	0	0	0	x	x	x

Bit Number	Bit Symbol	Description
5	INV5	PWM5 output reverse control bit 0: PWM5 output not invert 1: PWM5 output reverse
4	INV4	PWM4 output reverse control bit 0: PWM4 output not invert 1: PWM4 output reverse
3	INV3	PWM3 output reverse control bit 0: PWM3 output not invert 1: PWM3 output reverse
7~6, 2~0	-	Reserve

PWM0DTY0 (D5H) PWM0 Duty Cycle Configuration Register (Read/Write)

Bit Number	7	6	5	4	3	2	1	0
Bit Symbol	PDT0[7: 0]							
R/W	R/W	R/W	R/W	R/W	R/W	R/W	R/W	R/W
POR	0	0	0	0	0	0	0	0

Bit Number	Bit Symbol	Description
7 ~ 0	PDT0[7: 0]	PWM0 duty cycle length configuration;

		High level width of PWM0 is (PDT0[7: 0]) PWM clocks.
--	--	--

PWMDTY1 (D6H) PWM1 Duty Cycle Configuration Register (Read/Write)

Bit Number	7	6	5	4	3	2	1	0
Bit Symbol	PDT1[7: 0]							
R/W	R/W	R/W	R/W	R/W	R/W	R/W	R/W	R/W
POR	0	0	0	0	0	0	0	0

Bit Number	Bit Symbol	Description
7 ~ 0	PDT1[7: 0]	PWM1 duty cycle length configuration; High level width of PWM1 is (PDT1[7: 0]) PWM clocks.

PWMDTY2 (D7H) PWM2 Duty Cycle Configuration Register (Read/Write)

Bit Number	7	6	5	4	3	2	1	0
Bit Symbol	PDT2[7: 0]							
R/W	R/W	R/W	R/W	R/W	R/W	R/W	R/W	R/W
POR	0	0	0	0	0	0	0	0

Bit Number	Bit Symbol	Description
7 ~ 0	PDT2[7: 0]	PWM2 duty cycle length configuration; High level width of PWM2 is (PDT2[7: 0]) PWM clocks.

PWMDTY3 (DDH) PWM3 Duty Cycle Configuration Register (Read/Write)

Bit Number	7	6	5	4	3	2	1	0
------------	---	---	---	---	---	---	---	---

Bit Symbol	PDT3[7: 0]							
R/W	R/W	R/W	R/W	R/W	R/W	R/W	R/W	R/W
POR	0	0	0	0	0	0	0	0

Bit Number	Bit Symbol	Description
7 ~ 0	PDT3[7: 0]	PWM3 duty cycle length configuration; High level width of PWM3 is (PDT3[7: 0]) PWM clocks.

PWM4 Duty Cycle Configuration Register (Read/Write)

Bit Number	7	6	5	4	3	2	1	0
Bit Symbol	PDT4[7: 0]							
R/W	R/W	R/W	R/W	R/W	R/W	R/W	R/W	R/W
POR	0	0	0	0	0	0	0	0

Bit Number	Bit Symbol	Description
7 ~ 0	PDT4[7: 0]	PWM4 duty cycle length configuration; High level width of PWM4 is (PDT4[7: 0]) PWM clocks.

PWM5 Duty Cycle Configuration Register (Read/Write)

Bit Number	7	6	5	4	3	2	1	0
Bit Symbol	PDT5[7: 0]							
R/W	R/W	R/W	R/W	R/W	R/W	R/W	R/W	R/W
POR	0	0	0	0	0	0	0	0

Bit Number	Bit Symbol	Description
7 ~ 0	PDT5[7: 0]	PWM5 duty cycle length configuration; High level width of PWM5 is (PDT5[7: 0]) PWM clocks.

IE1 (A9H) Interrupt Enable Register (Read/Write)

Bit Number	7	6	5	4	3	2	1	0
Bit Symbol	-	-	-	-	EINT2	EBTM	EPWM	-
R/W	-	-	-	-	R/W	R/W	R/W	-
POR	x	x	x	x	0	0	0	x

Bit Number	Bit Symbol	Description
1	EPWM	PWM Interrupt Control Bit 0: Clear to disable the PWM interrupt 1: Set to enable the interrupt when PWM counter overflows

IP1 (B9H) Interrupt Priority Register 1 (Read/Write)

Bit Number	7	6	5	4	3	2	1	0
Bit Symbol	-	-	-	-	IPINT2	IPBTM	IPPWM	-
R/W	-	-	-	-	R/W	R/W	R/W	-
POR	x	x	x	x	0	0	0	x

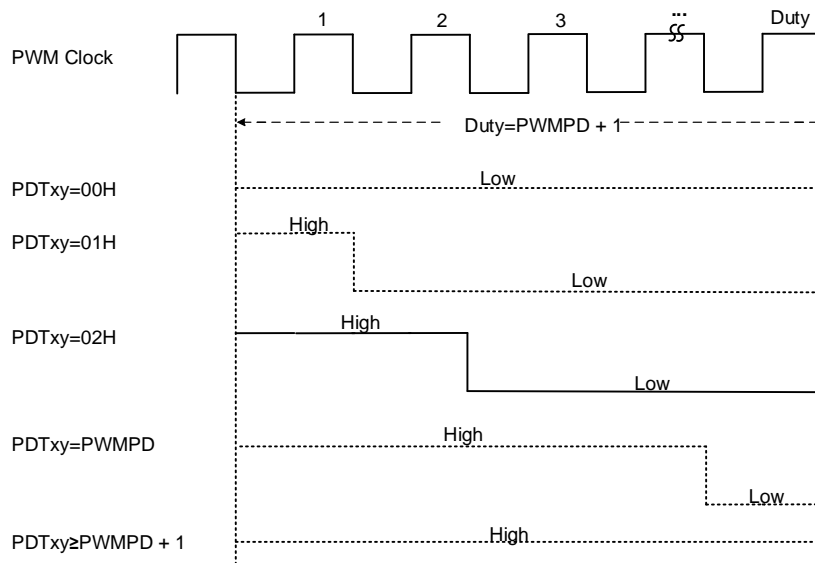

Diagram for Relationship between Period and Duty cycle

The relationship between period and duty cycle is shown in the figure above. The premise of this result is that the initial output inverse control (INVn) of pwn (n = 0 ~ 5) is 0. If the opposite result is needed, INVn can be set to 1.

Preliminary

13 GP I/O

The SC92F735X offers up to 18 bidirectional controllable GPIOs, input and output control registers are used to control the input and output state of various ports, when the port is used as input, each I/O port is equipped with internal pull-up resistor controlled by PxPHY. Such 18 IOs are shared with other functions, including P0.0 ~ P0.4 can be used as LCD COM driver by configuring output voltage as $1/2 V_{DD}$. Under output state, what I/O port read is the value of port data register

Note: Unused IO port or IO port with no package pin shall be configured as strong push-pull output mode.

13.1 GPIO Structure Diagram

Strong Push-pull Output Mode

In strong push-pull output mode, it is able to provide continuous high current drive: high output for the current larger than 16mA and low output for the current larger than 47mA

The port structure diagram for strong push-pull output mode is shown below:

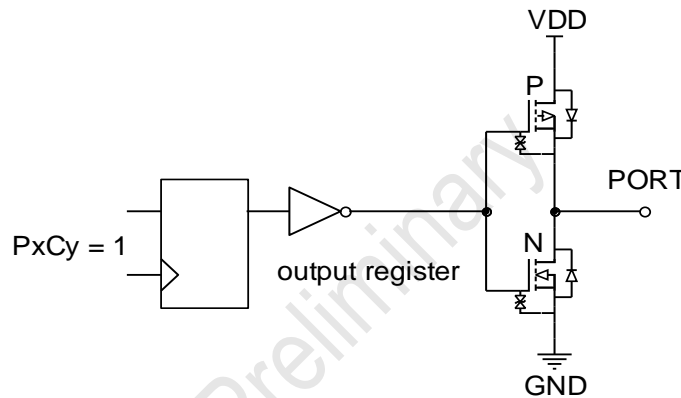

Strong Push-pull Output Mode

Pull-up Input Mode

In pull-up input mode, a pull-up resistor is connected on the input port, only when the level on the input port is pulled down, low level signal can be detected.

The port structure diagram for pull-up input mode is shown below:

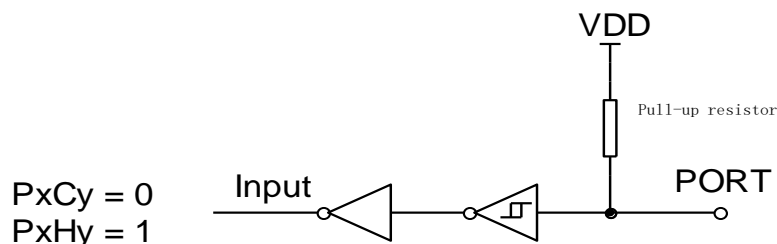

Pull-up Input Mode

High Impedance Input Mode. (Input only)

The port structure diagram for input only mode is shown below:

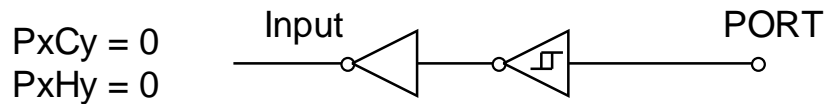

High- impedance Input Mode

13.2 I/O Port-related Registers

P0CON (9AH) P0 Input / Output Control Register (Read/Write)

Bit Number	7	6	5	4	3	2	1	0
Bit Symbol	-	-	P0C5	P0C4	P0C3	P0C2	P0C1	P0C0
R/W	-	-	R/W	R/W	R/W	R/W	R/W	R/W
POR	x	x	0	0	0	0	0	0

P0PH (9BH) P0 Pull-up Resistor Control Register (Read/Write)

Bit Number	7	6	5	4	3	2	1	0
Bit Symbol	-	-	P0H5	P0H4	P0H3	P0H2	P0H1	P0H0
R/W	-	-	R/W	R/W	R/W	R/W	R/W	R/W
POR	x	x	0	0	0	0	0	0

P1CON (91H) P1 Input / Output Control Register (Read/Write)

Bit Number	7	6	5	4	3	2	1	0
Bit Symbol	P1C7	P1C6	-	-	P1C3	P1C2	P1C1	P1C0
R/W	R/W	R/W	-	-	R/W	R/W	R/W	R/W
POR	0	0	x	x	0	0	0	0

P1PH (92H) P1 Pull-up Resistor Control Register (Read/Write)

Bit Number	7	6	5	4	3	2	1	0
Bit Symbol	P1H7	P1H6	-	-	P1H3	P1H2	P1H1	P1H0
R/W	R/W	R/W	-	-	R/W	R/W	R/W	R/W
POR	0	0	x	x	0	0	0	0

P2CON (A1H) P2 Input / Output Control Register (Read/Write)

Bit Number	7	6	5	4	3	2	1	0
Bit Symbol	P2C7	P2C6	P2C5	P2C4	-	-	P2C1	P2C0
R/W	R/W	R/W	R/W	R/W	-	-	R/W	R/W
POR	0	0	0	0	x	x	0	0

P2PH (A2H) P2 Pull-up Resistor Control Register (Read/Write)

Bit Number	7	6	5	4	3	2	1	0
Bit Symbol	P2H7	P2H6	P2H5	P2H4	-	-	P2H1	P2H0
R/W	R/W	R/W	R/W	R/W	-	-	R/W	R/W
POR	0	0	0	0	x	x	0	0

Bit Number	Bit Symbol	Description
7 ~ 0	PxCy (x=0 ~ 2, y=0 ~ 7)	Px port input and output control bit 0: Pxy as input mode (initial value) 1: Pxy as strong push-pull output mode
7 ~ 0	PxHy	Px port pull-up resistance configuration, only valid when PxCy=0: 0: Pxy as high-impedance input mode (initial value), the pull-up resistor

	(x=0 ~ 2, y=0 ~ 7)	is turned off. 1: Pxy pull-up resistance is turned on.
--	--------------------	---

P0 (80H) P0 Data Register (Read/Write)

Bit Number	7	6	5	4	3	2	1	0
Bit Symbol	-	-	P0.5	P0.4	P0.3	P0.2	P0.1	P0.0
R/W	-	-	R/W	R/W	R/W	R/W	R/W	R/W
POR	x	x	0	0	0	0	0	0

P1 (90H) P1 Data Register (Read/Write)

Bit Number	7	6	5	4	3	2	1	0
Bit Symbol	P1.7	P1.6	-	-	P1.3	P1.2	P1.1	P1.0
R/W	R/W	R/W	-	-	R/W	R/W	R/W	R/W
POR	0	0	x	x	0	0	0	0

P2 (A0H) P2 Data Register (Read/Write)

Bit Number	7	6	5	4	3	2	1	0
Bit Symbol	P2.7	P2.6	P2.5	P2.4	-	-	P2.1	P2.0
R/W	R/W	R/W	R/W	R/W	-	-	R/W	R/W
POR	0	0	0	0	x	x	0	0

IOHCON (97H) IOH Configuration Register (Read/Write)

Bit Number	7	6	5	4	3	2	1	0
Bit Symbol	P2H[1: 0]		P2L[1: 0]		POH[1: 0]		POL[1: 0]	

R/W	R/W	R/W	R/W	R/W	R/W	R/W	R/W	R/W
POR	0	0	0	0	0	0	0	0

Bit Number	Bit Symbol	Description
7 ~ 6	P2H[1: 0]	P2 high 4-bit IOH configuration bits 00: Set P2 high 4-bit IOH level 0 (Maximum value); 01: Set P2 high 4-bit IOH level 1; 10: Set P2 high 4-bit IOH level 2; 11: Set P2 high 4-bit IOH level 3 (Minimum value);
5 ~ 4	P2L[1: 0]	P2 low 4-bit IOH configuration bits 00: Set P2 low 4-bit IOH level 0 (Maximum value); 01: Set P2 low 4-bit IOH level 1; 10: Set P2 low 4-bit IOH level 2; 11: Set P2 low 4-bit IOH level 3 (Minimum value);
3 ~ 2	P0H[1: 0]	P0 high 4-bit IOH configuration bits 00: Set P0 high 4-bit IOH level 0 (Maximum value); 01: Set P0 high 4-bit IOH level 1; 10: Set P0 high 4-bit IOH level 2; 11: Set P0 high 4-bit IOH level 3 (Minimum value);
1 ~ 0	P0L[1: 0]	P0 low 4-bit IOH configuration bits 00: Set P0 low 4-bit IOH level 0 (Maximum value); 01: Set P0 low 4-bit IOH level 1; 10: Set P0 low 4-bit IOH level 2; 11: Set P0 low 4-bit IOH level 3 (Minimum value);

14 Software LCD DRIVER

The P0.0 ~ P0.4 of the SC92F735X can be used as the COM port of the software LCD. In addition to the normal IO functions, these IOs can also output 1/2VDD. The user can select the corresponding IO as the LCD driver COM according to the usage.

14.1 Software LCD Drives Relevant Registers

LCD Driver Related SFR Register Description:

P0VO (9CH) P0 port LCD voltage output register (Read/Write)

Bit Number	7	6	5	4	3	2	1	0
Bit Symbol	-	-	-	P04VO	P03VO	P02VO	P01VO	P00VO
R/W	-	-	-	R/W	R/W	R/W	R/W	R/W
POR	x	x	x	0	0	0	0	0

P0yVO (y=0 ~ 4)	P0y	P0y selection output port
0	x	Ordinary IO port
1	1	Open the LCD voltage output function of Pxy port. The output voltage of Pxy is 1/2VDD.

OTCON (8FH) Output Control Register (Read/Write)

Bit Number	7	6	5	4	3	2	1	0
Bit Symbol	-	-	-	-	VOIRS[1: 0]		-	-
R/W	-	-	-	-	R/W	R/W	-	-
POR	x	x	x	x	0	0	x	x

Bit Number	Bit Symbol	Description
3 ~ 2	VOIRS[1: 0]	<p>Selection bits of voltage dividing resistance of LCD voltage output port (suitable driving according to LCD screen size)</p> <p>00: Disable internal voltage divider resistor. (Energy saving)</p> <p>01: Set the internal partial resistance to 12.5K</p> <p>10: Set the internal partial resistance to 37.5K</p> <p>11: Set the internal partial resistance to 87.5K</p>

15 UART

15.1 UART-related Registers

SCON (98H) Serial Control Register (Read/Write)

Bit Number	7	6	5	4	3	2	1	0
Bit Mnemonic	SM0	SM1	SM2	REN	TB8	RB8	TI	RI
R/W	R/W	R/W	R/W	R/W	R/W	R/W	R/W	R/W
POR	0	0	0	0	0	0	0	0

Bit Number	Bit Mnemonic	Description
7~6	SM0~1	<p>Serial Communication Mode Control Bit 1</p> <p>00: Mode 0, 8-bit semi-duplex asynchronous communication, Send or receive serial data on RX pin, TX pin used as transmit shift clock. Every single frame send or receive 8-bit data, and low first.</p> <p>01: Mode 1, 10-bit full-duplex asynchronous communication composing of 1 starting bit, 8 data bits and 1 stopping bit, with communication baud rate changeable;</p> <p>10: Mode 2, 11-bit full-duplex asynchronous communication, composing of 1 starting bit, 8 data bits and 1 programmable 9th bit and 1 stopping bit. Communication baud rate fixed to 1 / 32 or 1 / 64 of system clock</p> <p>11: Mode 3, 11-bit full-duplex asynchronous communication, composing of 1 starting bit, 8 data bits and 1 programmable 9th bit and 1 stopping</p>

		bit, with communication baud rate changeable.
5	SM2	Serial Communication Mode Control Bit 2, this control bit is only valid for mode 2,3 0: Configure RI for receiving each complete data frame to generate interrupt request; 1: When receiving a complete data frame and only when RB8=1, will RI be configured to generate interrupt request.
4	REN	Receive Allowing Control Bit 0: Receiving data not allowed; 1: Receiving data allowed.
3	TB8	Only valid for mode 2 and mode 3, 9 th bit of sending data
2	RB8	Only valid for mode 2 and mode 3, 9 th bit of receiving data
1	TI	Transmit Interrupt Flag Bit
0	RI	Receive Interrupt Flag Bit

SBUF (99H) Serial Date Buffer (Read/Write)

Bit Number	7	6	5	4	3	2	1	0
Bit Mnemonic	SBUF[7: 0]							
R/W	R/W	R/W	R/W	R/W	R/W	R/W	R/W	R/W
POR	0	0	0	0	0	0	0	0

Bit Number	Bit Mnemonic	Description
7 ~ 0	SBUF[7: 0]	Serial Data Buffer SBUF contains two registers: one for transmit shift register and one for receiving latch, data writing to SBUF will be sent to shift register and initiate transmitting process, reading SBUF will return the contents of receiving latch.

PCON (87H) Power Control Register (only write)

Bit Number	7	6	5	4	3	2	1	0
Bit Mnemonic	SMOD	-	-	-	-	-	STOP	IDL
R/W	R/W	-	-	-	-	-	只写	只写
POR	0	x	x	x	x	x	0	0

Bit Number	Bit Mnemonic	Description
7	SMOD	Baud rate multiplier setting bit 0: when SM0~1=00, the serial port runs under 1/12 of the system clock, and when SM0 ~ 1 = 10, the serial port runs under 1/64 of the system clock; 1: when SM0~1=00, the serial port runs under 1/4 of the system clock, and when SM0 ~ 1 = 10, the serial port runs under 1/32 of the system clock;

15.2 Baud rate of serial communication

In Mode 0, the baud rate can be programmed to 1/12 or 1/4 of the system clock, which is determined by the SMOD (PCON. 7) bit. When SMOD is 0, the serial port runs at 1/12 of the system clock. When the SMOD is 1, the serial port runs at 1/4 of the system clock.

In Mode 1 and Mode3, the baud rate can be option as the overflow rate of T1 or T2.

Set TCLK (T2CON. 4) and RCLK (T2CON. 5) respectively to 1 in order to select Timer 2 as the baud clock source of TX and Rx (Check Timer1/2 section for more details). Whether TCLK or RCLK is logic 1, Timer 2 is baud rate generator mode. If TCLK and RCLK are logic 0, timer 1 is the baud clock source of TX and RX.

The baud rate formulas of Mode 1 and Mode 3 are as follows. TH1 is the 8-bit automatic reload register of Timer 1, SMOD is frequency doubler control bit of the baud rate of UART, and [RCAP2H, RCAP2L] is the 16-bit reload register of Timer 2.

1. Use Timer 1 as baud rate generator, and Timer 1 works in Mode 2:

$$\text{BaudRate} = \frac{2^{SMOD}}{16} \times \frac{fn1}{(256 - TH1) \times 2}$$

Fn1 is the clock frequency of Timer 1:

$$fn1 = \frac{fsys}{12}, \quad T1FD = 0$$

$$fn1 = fsys; \quad T1FD = 1$$

2. Use Timer 2 as baud rate generator

$$\text{BaudRate} = \frac{1}{16} \times \frac{\text{fn2}}{(65536 - [\text{RCAP2H}, \text{RCAP2L}]) \times 2}$$

Fn2 is the clock frequency of Timer 2:

$$\text{fn2} = \frac{\text{fsys}}{12}; \quad \text{T2FD} = 0$$

$$\text{fn2} = \text{fsys}; \quad \text{T2FD} = 1$$

The structure diagram of baud rate generator for Mode1 and Mode3 is shown below:

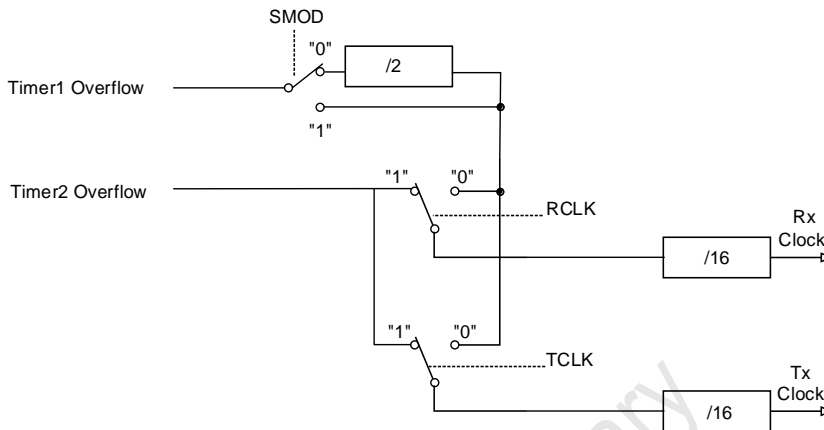

Mode1 and Mode3 baud rate generator structure diagram

In Mode 2, the baud rate is fixed to 1/32 or 1/64 of the system clock, which is determined by SMOD bit (PCON. 7). When the SMOD bit is 0, the baud rate is 1/64 of the system clock. When the SMOD bit is 1, the baud rate is 1/32 of the system clock.

16 Analog-to-digital converter (ADC)

The SC92F735X has a 12-bit high-precision successive approximation ADC with 9-channel, the external 8-channel is multiplexing with other IO ports. Cooperating with the internal 2.4V reference voltage, one internal channel connected to 1/4 V_{DD} can be used for measuring V_{DD} voltage.

There are 2 options for ADC reference voltage:

- ① VDD pin (internal V_{DD});
- ② Precise 2.4V reference output from internal Regulator.

16.1 ADC-related Registers

ADCCON (ADH) ADC Control Register (Read/Write)

Bit Number	7	6	5	4	3	2	1	0
Bit Symbol	ADCEN	ADCS	LOWSP	EOC/ADCIF	ADCIS[3: 0]			
R/W	R/W	R/W	R/W	R/W	R/W	R/W	R/W	R/W

POR	0	0	0	0	0	0	0	n
-----	---	---	---	---	---	---	---	---

Bit Number	Bit Symbol	Description
7	ADCEN	<p>ADC Power Control Bit</p> <p>0: Disable ADC module power</p> <p>1: Enable ADC module power</p>
6	ADCS	<p>ADC Start Trigger Control Bit (ADC Start)</p> <p>Write "1" for this bit, an ADC conversion started, this bit is the trigger signal only for ADC switch. This bit is valid only for writing "1".</p> <p>Note: After writing "1" to ADCS, do not write to the ADCCON register until the interrupt flag EOC/ADCIF is set.</p>
5	LOWSP	<p>ADC Sampling Clocks Selector:</p> <p>0: Set the clock frequency as 2MHz for ADC</p> <p>1: Set the clock frequency as 333kHz for ADC</p> <p>LOWSP controls ADC sampling clock frequency, conversion clock frequency of ADC is fixed at 2MHz, independent of the influence of LOWSP bit</p> <p>The whole process from sampling to conversion of ADC needs 6 ADC sampling clocks plus 14 ADC conversion clocks, therefore, in practical application, the total time of ADC from sampling to conversion shall be calculated as follows:</p> <p>LOWSP=0: $T_{ADC1} = 6 * (1/2\text{MHz}) + 14 * (1/2 \text{ MHz}) = 10\mu\text{s}$;</p> <p>LOWSP=1: $T_{ADC2} = 6 * (1/333\text{kHz}) + 14 * (1/2 \text{ MHz}) = 25\mu\text{s}$.</p>
4	EOC /ADCIF	<p>End Of Conversion / ADC Interrupt Flag</p> <p>0: Conversion not completed</p> <p>1: ADC conversion completed and need the user cleared up by software.</p> <p>ADC conversion completion flag EOC: when the user sets up ADCS for conversions, this bit will be cleared to 0 by hardware automatically; after completing conversion, this bit will be configured to 1 automatically by hardware;</p> <p>ADC interrupt request flag ADCIF: this bit is also used as interrupt request flag of ADC interrupt. If ADC interrupt is enabled, this bit must</p>

		be cleared by the user with software after ADC interrupt generated.
3 ~ 0	ADCIS[3: 0]	ADC Input Selection Bits 0000: Select AIN0 as ADC input 0001: Select AIN1 as ADC input 0100: Select AIN4 as ADC input 0101: Select AIN5 as ADC input 0110: Select AIN6 as ADC input 0111: Select AIN7 as ADC input 1000: Select AIN8 as ADC input 1001: Select AIN9 as ADC input 1111: ADC input is 1/4 VDD, used for measuring power voltage Others: Reserved

ADCCFG0 (ABH) ADC Configuration Register 0 (Read/Write)

Bit Number	7	6	5	4	3	2	1	0
Bit Symbol	EAIN7	EAIN6	EAIN5	EAIN4	-	-	EAIN1	EAIN0
R/W	R/W	R/W	R/W	R/W	-	-	R/W	R/W
POR	0	0	0	0	x	x	0	0

ADCCFG1 (ACH) ADC Configuration Register 1 (Read/Write)

Bit Number	7	6	5	4	3	2	1	0
Bit Symbol	-	-	-	-	-	-	EAIN9	EAIN8
R/W	-	-	-	-	-	-	R/W	R/W
POR	x	x	x	x	x	x	0	0

Bit Number	Bit Symbol	Description
0	EAINx (x=0~1,4~9)	ADC Port Configuration Register 0: Configure AINx as IO PORT 1: Configure AINx as ADC input and remove pull-up resistance automatically.

OP_CTM1 (C2H@FFH) Customer Option Register 1 (Read/Write)

Bit Number	7	6	5	4	3	2	1	0
Bit Symbol	VREFS	-	-	-	IAPS[1: 0]		-	-
R/W	R/W	-	-	-	R/W	R/W	-	-
POR	n	x	x	x	n	n	x	x

Bit Number	Bit Symbol	Description
7	VREFS	Reference Voltage Selection Bit (Default values are configured by the user and loaded from Code Option) 0: Configure ADC VREF as V _{DD} 1: Configure ADC VREF as internal correct 2.4 V

ADCVL (AEH) ADC Conversion Value Register (Low Bit) (Read/Write)

Bit Number	7	6	5	4	3	2	1	0
Bit Symbol	ADCV[3: 0]				-	-	-	-
R/W	R/W	R/W	R/W	R/W	-	-	-	-
POR	0	0	0	0	x	x	x	x

ADCVH (AFH) ADC Conversion Value Register (High Bit) (Read/Write)

Bit Number	7	6	5	4	3	2	1	0
Bit Symbol	ADCV[11: 4]							
R/W	R/W	R/W	R/W	R/W	R/W	R/W	R/W	R/W
POR	0	0	0	0	0	0	0	0

Bit Number	Bit Symbol	Description
11 ~ 4	ADCV[11: 4]	ADC conversion value high 8-bit values
3 ~ 0	ADCV[3: 0]	ADC conversion value low 4-bit values

IE (A8H) Interrupt Enable Register (Read/Write)

Bit Number	7	6	5	4	3	2	1	0
Bit Symbol	EA	EADC	ET2	ESSI0	ET1	-	ET0	EINT0
R/W	R/W	R/W	R/W	R/W	R/W	-	R/W	R/W
POR	0	0	0	0	0	x	0	0

Bit Number	Bit Symbol	Description
6	EADC	ADC Interrupt Enable Control Bit 0: EOC/ADCIF interrupt not allowed 1: EOC/ADCIF interrupt allowed

IP (B8H) Interrupt Priority Control Register (Read/Write)

Bit Number	7	6	5	4	3	2	1	0
------------	---	---	---	---	---	---	---	---

Bit Symbol	-	IPADC	IPT2	IPSSIO	IPT1	-	IPT0	IPINT0
R/W	-	R/W	R/W	R/W	R/W	-	R/W	R/W
POR	x	0	0	x	0	x	0	0

Bit Number	Bit Symbol	Description
6	IPADC	ADC Interruption Priority Selection Bit 0: Set the interrupt priority of ADC to be "low" 1: Set the interrupt priority of ADC to be "high"

16.2 ADC Conversion Steps

Operating steps for the user to practically conduct ADC conversion are shown below:

- ① Configure ADC input pin; (configure corresponding bit of AINx as ADC input, in general, ADC pin will be prefixed);
- ② Configure ADC reference voltage Vref and ADC conversion frequency;
- ③ Enable ADC;
- ④ Select ADC input channel; (Configure ADCIS bit and select ADC input channel);
- ⑤ Enable ADCS, and start conversion;
- ⑥ Wait for EOC/ADCIF=1, if ADC interrupt is enabled, ADC interrupt will be generated and the user shall clear EOC/ADCIF flag to 0 by software;
- ⑦ Obtain 12-bit data from ADCVH, ADCVL from high bit to low bit, and complete a conversion
- ⑧ If no change in input channel, repeat Step 5 to Step 7 for next conversion.

Note: Before setting up IE[6] (EADC), it is recommended for the user to use software to clear the EOC/ADCIF flag first. After completing ADC interrupt service process, user shall eliminate EOC/ADCIF to avoid generating ADC interrupt constantly.

17 EEPROM and IAP Operations

There are two modes of SC92F735X for the IAP operation space range:

EEPROM and IAP operation modes are as follows:

1. 128 bytes EEPROM can be used as data storage;
2. The Code area of IC and 128 bytes of EEPROM can be used for IAP operations, which is mainly used for remote program updating.

As Code Option, the user shall select EEPROM and IAP operating space before it is written to IC by programmer:

OP_CTM1 (C2H@FFH) Customer Option Register 1 (Read/Write)

Bit number	7	6	5	4	3	2	1	0
Bit symbol	VREFS	-	-	-	IAPS[1: 0]		-	-
R/W	R/W	-	-	-	R/W	R/W	-	-
POR	n	x	x	x	n	n	x	x

Bits	Name	Description
3 ~ 2	IAPS[1: 0]	<p>IAP Space Scope Selection Bits</p> <p>00: Code area prohibits IAP operations, only EEPROM area used for data storage</p> <p>01: Last 0.5k code area allows IAP operation (1E00H ~ 1FFFH)</p> <p>10: Last 1k code area allows IAP operation (1C00H ~ 1FFFH)</p> <p>11: All code area allows IAP operation (0000H ~ 1FFFH)</p>

17.1 EEPROM / IAP Operating-related Registers

Description for EEPROM / IAP operating-related registers:

Symbol	Address	Description	7	6	5	4	3	2	1	0	Reset value
IAPKEY	F1H	IAP Protection Register	IAPKEY[7: 0]								0000000b

IAPADL	F2H	IAP Write Address Low Register	IAPADR[7: 0]					00000000b	
IAPADH	F3H	IAP Write Address High Register	-	-	-	IAPADR[12:8]		xxx00000b	
IAPADE	F4H	IAP Write Extended Address Register	IAPADER[7: 0]					00000000b	
IAPDAT	F5H	IAP Data Register	IAPDAT[7: 0]					00000000b	
IAPCTL	F6H	IAP Control Register	-	-	-	-	PAYTIMES [1: 0]	CMD[1: 0]	xxxx0000b

IAPKEY (F1H) IAP Protection Register (Read/Write)

Bit Number	7	6	5	4	3	2	1	0
Bit Symbol	IAPKEY[7: 0]							
R/W	R/W	R/W	R/W	R/W	R/W	R/W	R/W	R/W
POR	0	0	0	0	0	0	0	0

Bit Number	Bit symbol	Description
7 ~ 0	IAPKEY[7: 0]	Enable EEPROM/IAP function and operation time limit configuration Write a non-zero value n, representing: <ol style="list-style-type: none"> ① Enable EEPROM / IAP function; ② If no writing command is received after n system clocks, EEPROM / IAP function will be reclosed.

IAPADL (F2H) IAP Write Address Low Register (Read/Write)

Bit Number	7	6	5	4	3	2	1	0
------------	---	---	---	---	---	---	---	---

Bit Symbol	IAPADR[7: 0]							
R/W	R/W	R/W	R/W	R/W	R/W	R/W	R/W	R/W
POR	0	0	0	0	0	0	0	0

Bit Number	Bit symbol	Description
7 ~ 0	IAPADR[7: 0]	EEPROM/IAP writing address low byte

IAPADH (F3H) IAP Write Address High Register (Read/Write)

Bit Number	7	6	5	4	3	2	1	0
Bit Symbol	-	-	-	IAPADR[12:8]				
R/W	-	-	-	R/W	R/W	R/W	R/W	R/W
POR	x	x	x	0	0	0	0	0

Bit Number	Bit symbol	Description
4~ 0	IAPADR[12:8]	EEPROM/IAP writing address high 5-bit
7 ~ 6	-	Reserved

IAPADE (F4H) IAP Write Extended Address Register (Read/Write)

Bit Number	7	6	5	4	3	2	1	0
Bit Symbol	IAPADER[7: 0]							
R/W	R/W	R/W	R/W	R/W	R/W	R/W	R/W	R/W

POR	0	0	0	0	0	0	0	0
-----	---	---	---	---	---	---	---	---

Bit Number	Bit symbol	Description
7 ~ 0	IAPADER[7: 0]	IAP Extended Address: 0x00: MOVC and IAP programming for Code 0x01: Conduct reading operation for user ID region, no writing operation is allowed 0x02: MOVC and IAP programming for EEPROM Other: Reserved

IAPDAT (F5H) IAP Data Register (Read/Write)

Bit Number	7	6	5	4	3	2	1	0
Bit Symbol	IAPDAT[7: 0]							
R/W	R/W	R/W	R/W	R/W	R/W	R/W	R/W	R/W
POR	0	0	0	0	0	0	0	0

Bit Number	Bit symbol	Description
7 ~ 0	IAPDAT	Data written by EEPROM/IAP

IAPCTL (F6H) IAP Control Register

Bit Number	7	6	5	4	3	2	1	0
Bit Symbol	-	-	-	-	PAYTIMES[1: 0]		CMD[1: 0]	
R/W	-	-	-	-	R/W	R/W	R/W	R/W
POR	x	x	x	x	0	0	0	0

Bit Number	Bit symbol	Description
3 ~ 2	PAYTIMES[1: 0]	<p>Upon EEPROM/IAP writing operation, CPU Hold Time length configuration</p> <p>00: Configure CPU HOLD TIME 6mS@24/12/6/2 MHz</p> <p>01: Configure CPU HOLD TIME 3mS@24/12/6/2 MHz</p> <p>10: Configure CPU HOLD TIME 1.5mS@24/12/6/2 MHz</p> <p>11: Reserved</p> <p>Notes: The CPU Hold is for PC pointer, other functional module continues to work; interrupt flag is saved, and interrupt is generated after completing Hold, but several times of interrupt can only be saved once.</p> <p>Recommended Selection: 2.7V ~ 5.5 V for V_{DD}, 10 is available</p> <p>2.4V ~ 5.5V for V_{DD}, 01 or 00 is available</p>
1 ~ 0	CMD[1: 0]	<p>EEPROM / IAP writing operating command</p> <p>10: Write</p> <p>Other: Reserved</p> <p>Note: The statement of EEPROM/IAP write operation shall be followed by at least 8 NOP instructions to guarantee subsequent instruction can be implemented normally after finishing IAP operation!</p>

17.2 EEPROM / IAP Operating Procedures:

Writing procedure of the SC92F735X EEPROM/IAP are shown below:

- ① Write 0x00 into IAPADE[7: 0]: select Code Area and conduct IAP operation; write 0x02 into IAPADE[7: 0]: select EEPROM and conduct EEPROM reading and writing operations;
- ② Write data into IAPDAT[7: 0] (data for EEPROM / IAP writing ready);
- ③ Write address into {IAPADR[12:8], IAPADR[7: 0]} (target address of EEPROM/IAP operation ready);
- ④ Write a nonzero value n into IAPKEY[7: 0] (switch on protection of EEPROM / IAP, and EEPROM / IAP function will be switched off when there is no writing command within n system clocks);
- ⑤ Write CPU Hold time into IAPCTL[3: 0] (configure CPU Hold time by setting CMD[1: 0] to 1 or 0, CPU is Hold up and start up EEPROM/IAP writing);
- ⑥ EEPROM/IAP writing ends, CPU proceeds to subsequent operations.

Notes: When programming IC, if “Code Area Prohibits IAP Operations” is selected by Code Option, IAP is

Page 92 of 109

unavailable upon IAPADE[7: 0]=0x00 (Select Code Area), meaning it is unable to write data, and such data can only be read by MOVC command.

17.2.1 128 bytes Independent EEPROM Operating Demo programme

```
#include "intrins.h"

unsigned char EE_Add;

unsigned char EE_Data;

unsigned char code * POINT =0x0000;
```

C Demo Program of EEPROM Write Operation:

```
EA = 0;                // Disable global Interrupt

IAPADE = 0x02;         //Select EEPROM Area

IAPDAT = EE_Data;     //Transmit data to EEPROM data register

IAPADH = 0x00;        // Write EEPROM target address high bit

IAPADL = EE_Add;      //Write EEPROM target address low bit

IAPKEY = 0xF0;        //This value can be adjusted as required: it shall guarantee that

                        // The time interval between this instruction implemented and writing
                        // IAPCTL value shall be less than 240 (0xf0) system clocks, or else, IAP function
                        // is closed;

                        //Pay special attention to enabling interrupt;

IAPCTL = 0x0A;        //Implement EEPROM write operation, 1ms@24/12/6/2MHz;

_nop_ ();             //Wait (at least 8 _nop_ ())

_nop_ ();

_nop_ ();

_nop_ ();

_nop_ ();

_nop_ ();

_nop_ ();

_nop_ ();

_nop_ ();

_nop_ ();

IAPADE = 0x00;        //Return to ROM Area

EA = 1;               //Enable master interrupt
```

C Demo Program of EEPROM Read Operation

```
EA = 0;                //Disable master interrupt

IAPADE = 0x02;        //Select EEPROM Area

EE_Data = * ( POINT +EE_Add);    //Read value in IAP_Add to IAP_Data

IAPADE = 0x00;        //Return to ROM Area , prevent MOVC operates to EEPROM

EA = 1;                // Enable global interrupt
```

17.2.2 8 Kbytes Code memory IAP Operating Demo programme

```
#include "intrins.h"

unsigned int IAP_Add;

unsigned char IAP_Data;

unsigned char code * POINT =0x0000;
```

C Demo Program of IAP Write Operation:

```
IAPADE = 0x00;        //Select Code Area

IAPDAT = IAP_Data;    //Transmit data to IAP data register

IAPADH = (unsigned char) ( (IAP_Add >> 8)); //Write IAP target address high bit

IAPADL = (unsigned char)IAP_Add;    //Write IAP target address low bit

IAPKEY = 0xF0;        //This value can be adjusted as required; it shall guarantee this
//instruction is implemented to assigned IAPTL value;

// Time interval shall be less than 240 (0xf0) system clocks, or
// else, IAP function is closed;

//Pay special attention upon starting interrupt

IAPCTL = 0x0A;        //Implement EEPROM write operation, 1ms@24/12/6/2MHz;

_nop_ ();            //Wait (at least 8 _nop_ ())

_nop_ ();

_nop_ ();

_nop_ ();

_nop_ ();

_nop_ ();

_nop_ ();

_nop_ ();

_nop_ ();
```

C Demo Program of IAP Read Operation:

```
IAPADE = 0x00;           //Select Code Area  
  
IAP_Data = * ( POINT+IAP_Add); //Read value in IAP_Add to IAP_Data
```

Note: IAP operation in 8 Kbytes Code has certain risks, the user shall implement corresponding safety measures in software. Misoperation may result in the user programme to be rewritten! Unless such function is required by the user (such as used for remote programme update, etc.), it is not recommended to used by the user.

Preliminary

18 Electrical Characteristics

18.1 Absolute Maximum Ratings

Symbol	Parameter	Min Value	Max Value	Unit
V _{DD} /V _{SS}	DC supply voltage	-0.3	5.5	V
Voltage ON any Pin	Input / Output voltage of any pin	-0.3	V _{DD} +0.3	V
T _A	Ambient temperature	-40	85	°C
T _{STG}	Storage temperature	-55	125	°C

18.2 Recommended Operating Conditions

Symbol	Parameter	Min Value	Max Value	Unit	System Clock Frequency
V _{DD1}	Operating voltage	3.7	5.5	V	24MHz
V _{DD2}	Operating voltage	2.4	5.5	V	12/6/2MHz
T _A	Ambient temperature	-40	85	°C	-

18.3 DC Electrical Features

(V_{DD} = 5V, T_A = +25°C, unless otherwise specified)

Symbol	Parameter	Min Value	Typical Value	Max Value	Unit	Testing Conditions
Current						
I _{op1}	Operating current	-	10	-	mA	f _{sys} =24MHz
I _{op2}	Operating current	-	7	-	mA	f _{sys} =12MHz

I _{op3}	Operating current	-	6	-	mA	f _{sys} =6MHz
I _{op4}	Operating current	-	5	-	mA	f _{sys} =2MHz
I _{pd1}	Standby Current (Power Down Mode)	-	0.7	1.0	μA	-
I _{IDL}	Standby Current (IDLE Mode)	-	6.7	-	mA	-
I _{BTM}	Base Timer Operating Current	-	6	8	μA	BTMFS[3: 0]= 1000 One interrupt occurs for every 4.0 seconds
I _{WDT}	WDT Current	-	4	6	μA	WDTCKS[2: 0]= 000 WDT overflows every 500ms
I/O Port Features						
V _{IH1}	Input high voltage	0.7V _{DD}	-	V _{DD} +0.3	V	
V _{IL1}	Input low voltage	-0.3	-	0.3V _{DD}	V	
V _{IH2}	Input high voltage	0.8V _{DD}	-	V _{DD}	V	Schmidt trigger input:
V _{IL2}	Input low voltage	-0.2	-	0.2V _{DD}	V	RST/tCK/SCK
I _{OL1}	Output low current	-	28	-	mA	V _{Pin} =0.4V
I _{OL2}	Output low current	-	47	-	mA	V _{Pin} =0.8V
I _{OH1}	Output high current Pxyz=0	-	16	-	mA	V _{Pin} =4.3V
	Output high current		13		mA	

	Pxyz=1					
	Output high current Pxyz=2		9		mA	V _{Pin} =4.3V P0/P2 I _{OH} level 2
	Output high current Pxyz=3		5		mA	V _{Pin} =4.3V P0/P2 I _{OH} level 3
I _{OH2}	Output high current Pxyz=0		7		mA	V _{Pin} =4.7V P0/P2/P1 I _{OH} level 0
	Output high current Pxyz=1		6		mA	V _{Pin} =4.7V P0/P2 I _{OH} level 1
	Output high current Pxyz=2		4		mA	V _{Pin} =4.7V P0/P2 I _{OH} level 2
	Output high current Pxyz=3	-	2	-	mA	V _{Pin} =4.7V P0/P2 I _{OH} level 3
R _{PH1}	Pull-up resistance	-	30	-	kΩ	
Internal calibrated 2.4V as ADC reference voltage						
V _{DD24}	Internal reference 2.4V voltage output	2.37	2.40	2.45	V	T _A =-40 ~ 85°C

(V_{DD} = 3.3V, T_A = +25°C, unless otherwise specified)

Symbol	Parameter	Min Value	Typical Value	Max Value	Unit	Conditions
Current						
I _{op5}	Operating current	-	7.0	-	mA	f _{sys} =24MHz
I _{op6}	Operating current	-	5.0	-	mA	f _{sys} =12MHz
I _{op7}	Operating current	-	4.2	-	mA	f _{sys} =6MHz

I _{op8}	Operating current	-	3.6	-	mA	f _{sys} =2MHz
I _{pd2}	Standby Current (Power Down Mode)	-	0.7	1	μA	
I _{IDL2}	Standby Current (IDLE Mode)	-	4.7	-	mA	
I/O Port Features						
V _{IH3}	Input high voltage	0.7V _{DD}	-	V _{DD} +0.3	V	
V _{IL3}	Input low voltage	-0.3	-	0.3V _{DD}	V	
V _{IH4}	Input high voltage	0.8V _{DD}	-	V _{DD}	V	Schmidt trigger input: RST/tCK/SCK
V _{IL4}	Input low voltage	-0.2	-	0.2V _{DD}	V	
I _{OL3}	Output low current	-	20	-	mA	V _{Pin} =0.4V
I _{OL4}	Output low current	-	38	-	mA	V _{Pin} =0.8V
I _{OH5}	Output high current P _{xyz} =0	-	7	-	mA	V _{Pin} =3.0V
R _{PH2}	Pull-up resistance	-	52	-	kΩ	
Internal calibrated 2.4V as ADC reference voltage						
V _{DD24}	Internal reference 2.4V voltage output	2.37	2.40	2.45	V	TA=-40 ~ 85°C

18.4 AC Electrical Features

(V_{DD} = 2.4V ~ 5.5V, TA = 25°C, unless otherwise specified)

Symbol	Parameter	Min	Typical	Max	Unit	Conditions
--------	-----------	-----	---------	-----	------	------------

T _{POR}	Power On Reset time	-	5	10	ms	
T _{PDW}	Power Down Mode waking-up time	-	1	1.5	ms	
T _{Reset}	Reset Pulse Width	18	-	-	μs	Valid for Low level
f _{HRC}	RC oscillation stability	23.76	24	24.24	MHz	V _{DD} =4.0~5.5V T _A =-20~85 °C

18.5 ADC Electrical Features

(T_A= 25°C, unless otherwise specified)

Symbol	Parameter	Min	Typical	Max	Unit	Conditions
V _{AD}	Supply Voltage	3.0	5.0	5.5	V	
N _R	Precision	-	12	-	bit	GND ≤ V _{AIN} ≤ V _{DD}
V _{AIN}	ADC Input Voltage	GND	-	V _{DD}	V	
R _{AIN}	ADC input resistance	1	-	-	MΩ	V _{IN} =5V
I _{ADC1}	ADC conversion current 1	-	-	2	mA	ADC Module on V _{DD} =5V
I _{ADC2}	ADC conversion current 2	-	-	1.8	mA	ADC module on V _{DD} =3.3V
DNL	Differential nonlinear error	-	-	±1	LSB	V _{DD} =5V V _{REF} =5V
INL	Integral nonlinear error	-	-	±2	LSB	
E _Z	Offset error	-	-	±3	LSB	
E _F	Full scale error	-	-	±3	LSB	

E _{AD}	Total absolute error	-	-	±8	LSB	
T _{ADC1}	ADC conversion time 1	-	10	-	μs	ADC Clock = 2MHz
T _{ADC2}	ADC conversion time 2	-	25	-	μs	ADC Clock = 333kHz

Preliminary

19 Ordering Information

product No	Pkg	Packing
SC92F7352Q20R	QFN20	TRAY
SC92F7352X20U	TSSOP20L	Tube
SC92F7352M20U	SOP20L	Tube
SC92F7352N20U	NSOP20L	Tube
SC92F7351M16U	SOP16L	Tube
SC92F7350M08U	SOP8L	Tube

Preliminary

20 Packageing Information

SC92F7352Q20R

QFN20(4X4) Dimension

Unit: mm

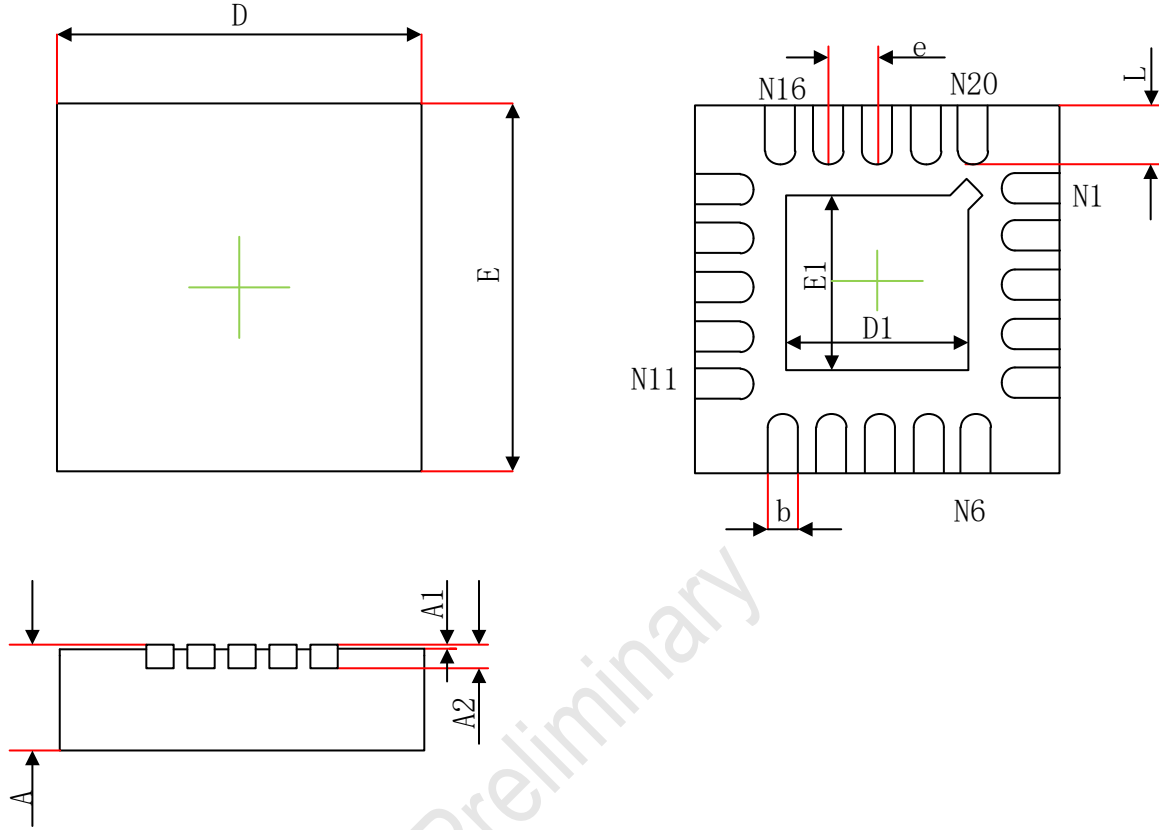

Symbol	mm		
	Min	Normal	Max
A	0.700	0.750	0.800
A1	0	-	0.050
A2	0.153	0.203	0.253
b	0.180	0.250	0.300
D	3.900	4.000	4.100
D1	1.900	2.000	2.100
E	3.900	4.000	4.100
E1	1.900	2.000	2.100
e	0.450	0.500	0.550
L	0.390	0.400	0.410

SC92F7352X20U

TSSOP20L Dimension Unit: mm

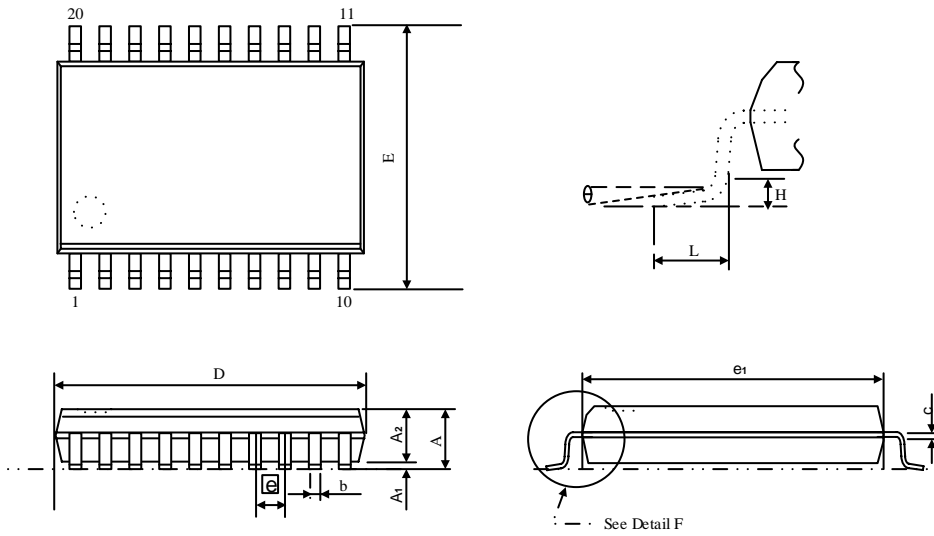

Symbol	mm		
	Min	Normal	Max
A	-	-	1.200
A1	0.050	-	0.150
A2	0.800	-	1.050
b	0.190	-	0.300
c	0.090	-	0.200
D	6.400	-	6.600
E	6.20	-	6.60
e1	4.300	-	4.500
\boxed{e}	0.65(BSC)		
L	-	-	1.00
θ	0°	-	8°
H	0.05	-	0.15

SC92F7352M20U

SOP 20L(300mil) Dimension Unit: mm

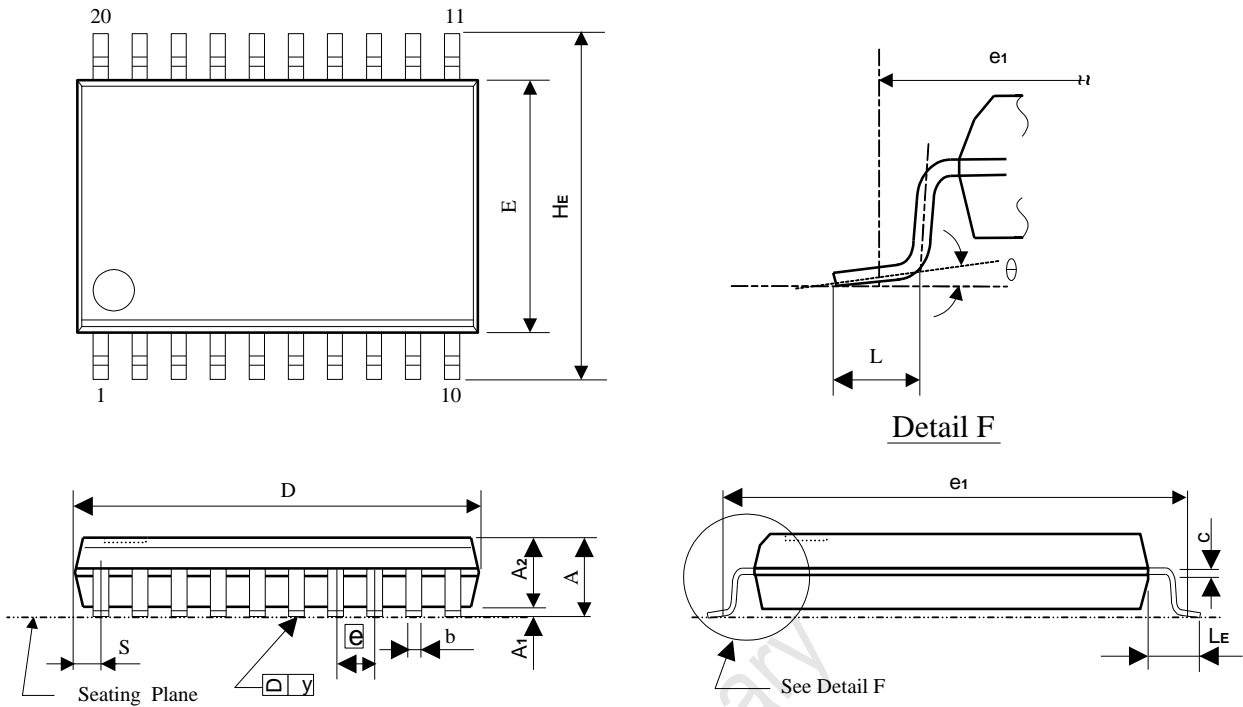

Symbol	mm		
	Min	Normal	Min
A	2.47	2.56	2.65
A1	0.100	0.200	0.300
A2	2.240	2.340	2.440
b	0.39	--	0.47
C	0.254(BSC)		
D	12.60	12.80	13.00
E	7.30	7.50	7.70
HE	10.100	10.300	10.500
\bar{e}	1.27(BSC)		
L	0.700	0.850	1.000
LE	1.30	1.40	1.50
θ	0°	-	8°
S	0.660(BSC)		

SC92F7352N20U

NSOP 20L(150mil) Dimension Unit: mm

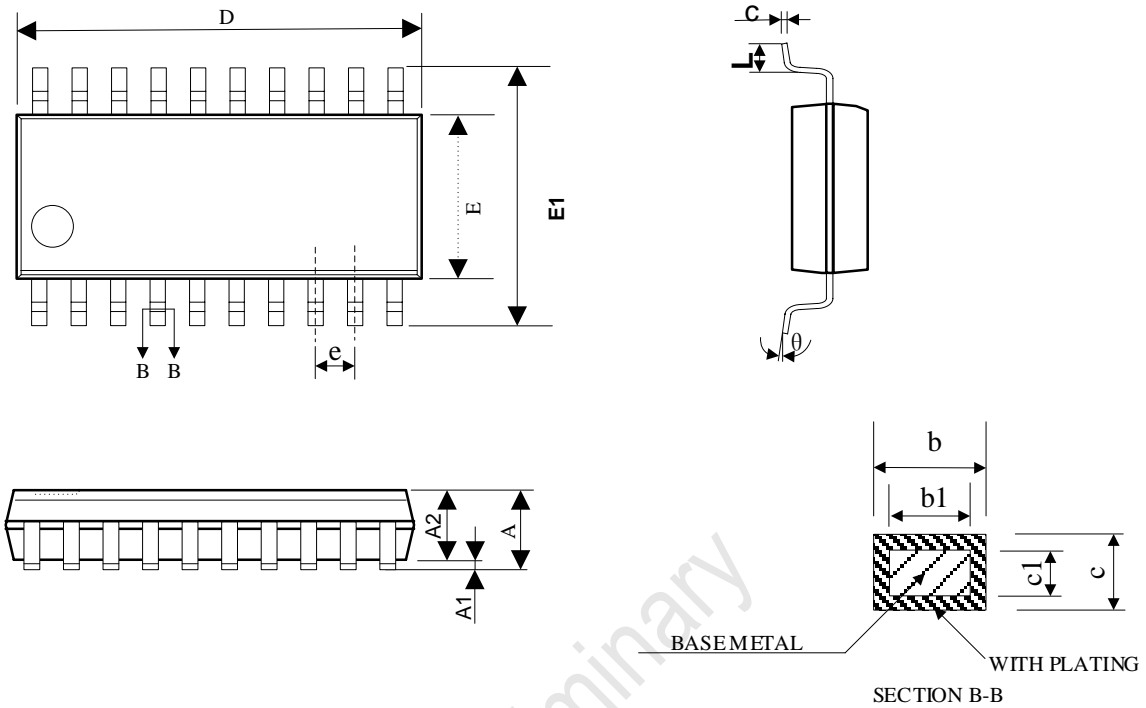

Symbol	mm	
	Min	Max
A	1.350	1.750
A1	0.100	0.250
A2	1.350	1.550
b	0.330	0.510
b1	0.320	0.500
c	0.170	0.250
c1	0.160	0.240
D	9.800	10.200
E	3.800	4.000
E1	5.800	6.200
e	1.000BSC	
L	0.400	0.800
θ	0°	8°

SC92F7351M16U

SOP 16L(150mil) Dimension Unit: mm

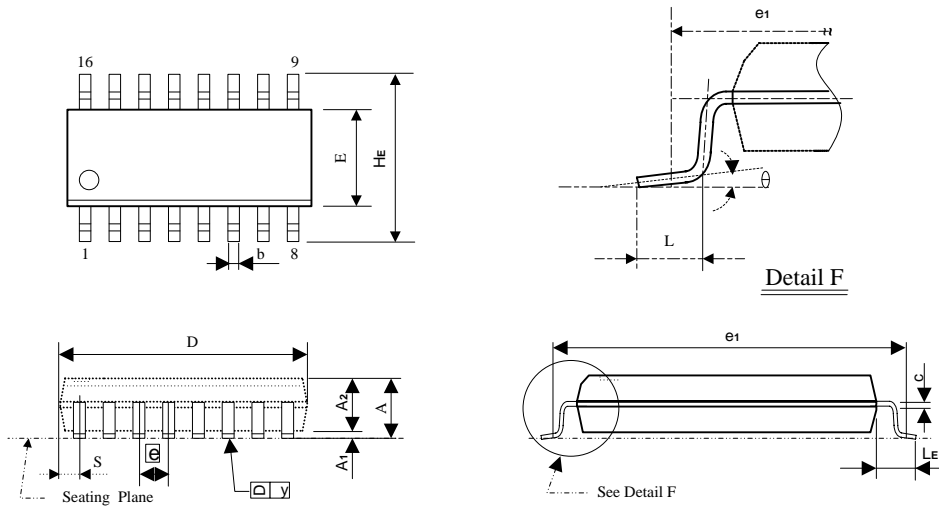

Symbol	mm		
	Min	Normal	Min
A	1.500	1.625	1.750
A1	0.050	0.1375	0.225
A2	1.35	1.45	1.55
b	0.39	0.435	0.48
C	0.254(BSC)		
D	9.700	9.900	10.100
E	3.700	3.900	4.100
HE	5.800	5.950	6.100
\bar{e}	1.27(BSC)		
L	0.500	0.650	0.800
LE	0.950	1.050	1.150
θ	0°	-	8°
S	0.505(BSC)		

SC92F7350M08U

SOP 8L(150mil) Dimension Unit: mm

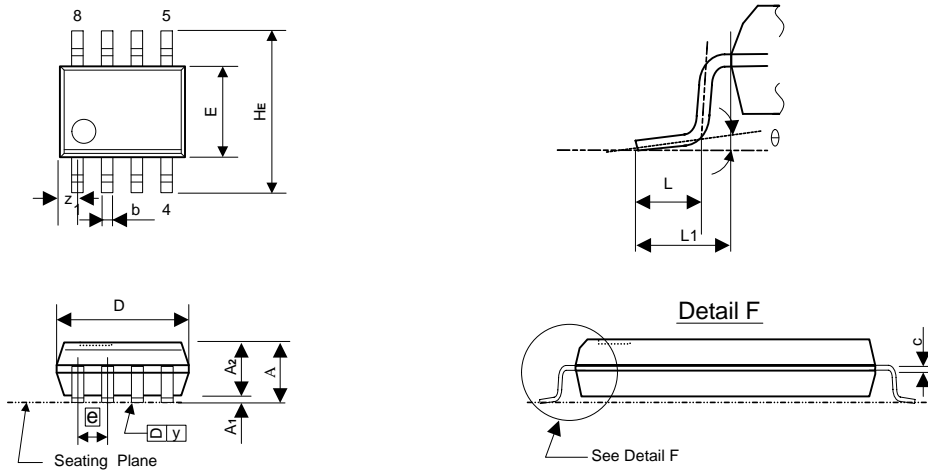

Symbol	mm		
	Min	Normal	Max
A	1.500	1.625	1.750
A1	0.100	0.1625	0.225
A2	1.30	1.425	1.55
b	0.39	0.435	0.48
C	0.2	0.23	0.26
D	4.70	4.90	5.10
E	3.70	3.90	4.10
HE	5.800	6.000	6.200
e	1.270(BSC)		
L	0.50	0.650	0.80
L1	0.950	1.050	1.150
θ	0°	-	8°

21 Revision History

Version	Notes	Date
V0.1	Initial Release.	March 2021

Preliminary