

Super High-speed 1T 8051 Core Flash MCU, 8 Kbytes SRAM, 64 Kbytes Flash, 0~4 Kbytes LDRAM, 6 Kbytes Independent LDRAM, 31-channel high sensitivity TouchKey circuits, 12-bit ADC, 14-channel 16-bit PWM, 5 Timers, MDU, UART, 6-channel USCI, CRC Check Module, 1 Analog Comparator

1 General Description

SC95F8617B/8616B/8615B/8613B/8612B (hereinafter referred to as the SC95F861XB) is a series of enhanced 1T 8051 core industry-standard Flash Microcontroller unit (MCU) with integrated TouchKey function, the instruction set is compatible with the standard 8051 series.

The SC95F861XB has a Super-high-speed 1T 8051 CPU core with an operating frequency of up to 32 MHz.

The SC95F861X integrates a hardware multiplier and divider hardware CRC and dual DPTR data pointers to accelerate data operations and movement speed. The hardware multiplier and divider and hardware CRC does not occupy CPU cycles, and the operation is implemented by hardware, and the speed is faster than the multiplication and division speed realized by software; dual DPTR data pointers can be used to accelerate data storage and movement.

The SC95F861XB has high performance and reliability, with a wide operating voltage of 2.0V~5.5V, a super-wide operating temperature of -40°C to 105°C, and has good ESD performance and EFT anti-interference ability. Using the industry-leading eFlash process, the Flash can be written more than 100,000 times, and can be stored for 100 years at room temperature.

The SC95F861XB has a built-in low power consumption WDT Watchdog Timer. It has a 4-level selectable voltage LVR low voltage reset function and a system clock monitoring function. It has low power consumption capability in operation and power-down modes. Under normal operating mode: about 6mA@32M at 5V.

The SC95F861XB series is also integrated with super rich hardware resources: built-in 31-channel (high sensitivity) touchkey circuits, 64 Kbytes Flash ROM, SRAM: internal 256 bytes+ external 8 Kbytes+ PWM&LCD 80 bytes、6 Kbytes EEPROM,; up to 46 GP I/O (partially gradable control), 16 IO can be externally interrupted, 5 16-bit timers, 14-channel 16-bit PWM:8-channel multi-function dead zone complementary PWM,6 channel PWM output of timer,1 UART,6 USCI(UART/SPI/IIC), Built-in LCD/LED hardware driver, internal $\pm 2\%$ high-precision high-frequency 32/16/8/4 MHz oscillator and $\pm 4\%$ precision low-frequency 32 kHz oscillator, external 32.768 kHz resources such as crystal oscillators. 1 analog comparator, 17 channels 12-bit high precision ADC.

The SC95F861XB is very convenient for development and debugging, with ISP (In-System Programming), ICP (In-Circuit Programming) and IAP (In-Application Programming). Allow the chip to debug and upgrade the program memory directly on the circuit board when the chip is online or powered.

The SC95F861XB has very excellent anti-jamming performance and excellent touchkey performance. It is very suitable for various applications about touchkey and main control system, such as Intelligent home appliances and Intelligent House System, Internet of things, wireless communication, game consoles and other industrial controls, and Consumer application areas.

2 Features

Operating Conditions

- Voltage Range: 2.0V~5.5V
- Temperature Range: -40°C ~ +105°C

EMS

- ESD
 - HBM: MIL-STD-883J Class 3A
 - MM: JEDEC EIA/JESD22-A115 Class C
 - CDM: ANSI/ESDA/JEDEC JS-002-2018 Class C3
- EFT
 - EN61000-4-4 Level 4

Package

- 20 PIN: SOP20 / TSSOP20
- 28 PIN: SOP28 / TSSOP28
- 32 PIN: LQFP32 (7X7)
- 44 PIN: LQFP44 (10X10)
- 48 PIN: LQFP48 (7X7)

CPU

- Super-high-speed 1T 8051 core
- The instruction set compatible with 8051
- The execution speed is about twice that of other 1T 8051
- Double data pointers (DPTRs)
- Flash ROM64 Kbytes Flash ROM
- MOVC disables addressing 0000H ~ 00FFH
- Can be rewritten 100,000 times
- APROM area allowed IAP operation in Flash can be set to 0K/1K/2K/All APROM by Code Option.

LDROM

- BootLoader code memory

- LDRAM area can be set to 0K/1K/2K/4K by Code Option

EEPROM

- Independent 6 Kbytes EEPROM
- Can be rewritten 100,000 times, has more than 100-year preservation life in the ambient temperature of 25°C

SRAM

- 256 bytes on-chip direct access RAM
- 8 Kbytes on-chip Indirect access RAM
- 80 bytes PWM&LCD RAM

Flash Programming and Emulation

- 2-wire JTAG programming and emulation interface

System clock (f_{sys})

- Built-in high frequency 32 MHz oscillator (f_{HRC})
 - can be selected and set by the programmer as: 32/16/8/4 MHz @ 2.0~5.5V
 - Frequency Error: Within $\pm 1\%$ @ -40 ~ 85°C @ 2.0 ~ 5.5V
 - Frequency Error: Within $\pm 2\%$ @ -40 ~ 105°C @ 2.0 ~ 5.5V
 - The system clock can be automatically calibrated by 32.768 kHz external crystal oscillator, after calibration HRC accuracy can be infinitely close to the accuracy of external 32.768 kHz crystal oscillator.

Built-in low-frequency crystal oscillator circuit:

- 32.768k oscillator can be connected externally as a Base Timer clock source.

Built-in low-frequency 32 kHz oscillator (LRC):

- used as the clock source for Base Timer and WDT and wake up STOP
- Frequency Error: After the register correction, within $\pm 4\%$ @ -20 ~ 85°C @ 4.0 ~ 5.5V

Low-voltage Reset (LVR)

- 4 options of reset voltage: 4.3/3.7/ 2.9/1.9V,
- the default value can be selected by the Code Option

Interrupts (INT)

- Timer 0~Timer 4, INT0~2, ADC, PWM, UART, USCIO~5, Base Timer, TK, CMP 20 interrupt sources

- External interrupt contains 3 interrupt vectors, 16 interrupt ports. All can set up rising edge, falling edge, dual edge interrupt.
- Two-level interrupt priority capability

Digital Peripheral

- GPIO: Up to 46 bidirectional independently controllable I/O ports
 - Independent setting of pull-up resistors
 - P0~P3L(P3.0/1/2/3) port source drive capacity is controlled by four levels
 - All IO ports have large sink current drive capability (50mA)
- Built-in WDT, optional clock frequency division ratio
- 5 Timers: Timer0~4, Timer1, Time2, Timer3 and Timer4
 - Time2, Timer3 and Timer4 have Capture function
 - Time2, Timer3 and Timer4 each can provide two conventional PWM
- 6-channel 16-bit conventional PWM
 - Time2, Timer3 and Timer4 each can provide two conventional PWM
- 8-channel 16-bit multi-function PWM
 - Public cycle and the duty cycle can be set separately
 - Complementary PWM waveforms with dead zones can be output
- One independent UART communication port UART0
- Six UART/SPI/TWI communication interfaces (USCI)
 - When USCI0 is set to SPI0, the driving capability of the pins corresponding to its signal port will be enhanced
- Built-in CRC check module
- Integrated with 16 * 16-bit hardware Multiplier-Divide Unit (MDU)

LCD/LED driver

- Choose one of two LCD/LED, share registers and IO ports
- 8 X 24, 6 X 26, 5 X 27, or 4X 28 segments LED driver
- LED segment port source drive capability is selectable in four levels
- 8 X 24, 6 X 26, 5 X 27, or 4X 28 segments LCD driver

Analog Peripheral

- 31-channel high sensitivity TouchKey (TK) circuit.
 - Applicable to TouchKey sensor, proximity induction and other TouchKey applications featuring high requirements on sensitivity
 - Have very strong anti-interference ability which is able to pass 10V dynamic CS test
 - Support self-capacitance and reciprocal- capacitance mode.
 - Support low power consumption mode.
 - Complete development support: High-flexible touch software library, intelligent software of debugging.
- 17-channel 12-bit ± 2 LSB ADC
 - Build-in reference voltage of 2.048V, 1.024V and 2.4V
 - The ADC reference voltages is optional: VDD, internal 2.048V, internal 1.024V and 2.4V
 - 1 internal channel can measure the voltage of the power supply
 - ADC conversion complete interruption can be set
- 1 Analog Comparator
 - 4-channel input and 1-channel reference voltage input
 - 16-level optional comparison voltage

Power Saving Mode

- IDLE Mode: can be woken up by any interrupt
- STOP Mode: can be woken up by INT0~2, Base Timer TK and CMP.

Naming Rules for 95 Series Products

Name	SC	95	F	8	6	1	7	X	P	48	R
S/R	①	②	③	④	⑤	⑥	⑦	⑧	⑨	⑩	⑪

S/R	Meaning
①	SinOne Chip abbreviation
②	Name of product series
③	Product Type (F: Flash MCU)
④	Serial Number: 7: GP Series, 8: TK series
⑤	ROM Size: 1 for 2K, 2 for 4K, 3 for 8K, 4 for 16K, 5 for 32K and 6 for 64K
⑥	Subseries Number.: 0 ~ 9, A ~ Z
⑦	Number of Pins: 0: 8pin, 1: 16pin, 2: 20pin, 3: 28pin, 5: 32pin, 6: 44pin, 7: 48pin, 8: 64pin, 9: 100pin
⑧	Version:(default, B, C, D)
⑨	Package Type: (D: DIP; M: SOP; X: TSSOP; F: QFP; P: LQFP; Q: QFN; K: SKDIP)
⑩	Number of Pins.
⑪	Packaging Mode: (U: Tube; R: Tray; T: Reel)

Ordering Information

PRODUCT ID	PACKAGE	PACK
SC95F8612BM20U	SOP20	TUBE
SC95F8612BX20U	TSSOP20	TUBE
SC95F8613BM28U	SOP28	TUBE
SC95F8613BX28U	TSSOP28	TUBE
SC95F8615BP32R	LQFP32(7X7)	TRAY
SC95F8616BP44R	LQFP44(10 X10)	TRAY
SC95F8617BP48R	LQFP48(7X7)	TRAY

Contents

1 GENERAL DESCRIPTION	1
2 FEATURES.....	2
NAMING RULES FOR 95 SERIES PRODUCTS.....	6
ORDERING INFORMATION	7
CONTENTS	8
3 PIN DESCRIPTION	12
3.1 Pin Configuration.....	12
3.1.1 48/44 Pin Definition.....	16
4 INNER BLOCK DIAGRAM	25
5 FLASH ROM AND SRAM	26
5.1 APROM and LDROM	26
5.1.1 Flash ROM Sectors	27
5.2 6K bytes independent EEPROM.....	27
5.3 96 bits Unique ID Area.....	28
5.3.1 Unique ID Read Operating Demo Program In C Language	29
5.4 User ID Area.....	29
5.5 Programming.....	30
5.6 In Application Programming (IAP)	31
5.6.1 IAP Operation Related Register	33
5.6.2 IAP Operation process.....	36
5.6.3 IAP Operating Demo Program In C Language	36
5.6.4 IAP Operation notes	37
5.7 BootLoader	38
5.7.1 BootLoader Mode operation related registers	38
5.8 Encryption	43
5.9 Code Option Area (User Programming Settings)	45
5.9.1 Customer-Option-related Registers Operation Instructions	49
5.10 SRAM.....	50
5.10.1 Internal 256 Bytes SRAM	50
5.10.2 External 8 Kbytes SRAM	52
5.10.3 External 80 bytes PWM&LCD/LED SRAM	52
6 SPECIAL FUNCTION REGISTER (SFR)	53
6.1 SFR Mapping	53
6.2 SFR Instructions	54
6.2.1 SFR.....	54
6.2.2 PWM0 Duty Cycle Adjustment Register(R/W)	61
6.2.3 PWM2~4 Duty Cycle Adjustment Register(R/W).....	61
6.2.4 LCD/LED display RAM configuration (R/W)	62
6.2.5 Introduction of Common Special Function Registers of 8051 Core.....	63

Program Counter PC	63
Accumulator ACC (E0H)	63
B Register (F0H)	63
Stack Pointer SP (81H)	64
Data Pointers DPTR0 (82H, 83H), DPTR1 (84H, 85H) And Its Selection Register DPS (86H)	65
7 POWER, RESET AND SYSTEM CLOCK	68
7.1 Power Circuit	68
7.2 Power-on Reset	68
7.2.1 Reset Stage	68
7.2.2 Loading Information Stage	68
7.2.3 Normal Operation Stage	68
7.3 Reset Modes	68
7.3.1 External Reset	69
7.3.2 Low-voltage Reset LVR	69
7.3.3 Power-on Reset (POR)	70
7.3.4 Watchdog Reset (WDT)	70
7.3.5 Software Reset	72
7.3.6 Register Reset Value	73
7.4 High- frequency System Clock Circuit	73
7.5 Low- frequency RC Oscillator and Low- frequency Clock Timer	76
7.6 Power Saving Modes	79
8 CPU AND INSTRUCTION SET	81
8.1 CPU	81
8.2 Addressing Mode	81
8.2.1 Immediate Addressing	81
8.2.2 Direct Addressing	81
8.2.3 Indirect Addressing	81
8.2.4 Register Addressing	82
8.2.5 Relative Addressing	82
8.2.6 Indexed Addressing	82
8.2.7 Bits Addressing	82
9 INTERRUPTS	84
9.1 Interrupt Source and Vector	84
9.2 Interrupt Structure Diagram	87
9.3 Interrupt Priority	88
9.4 Interrupt Processing Flow	88
9.5 Interrupt-related SFR Registers	88
10 TIMER/COUNTER T0 AND T1	101
10.1 T0 and T1-related Registers	101
10.2 T0 Operating Modes	106
10.3 T1 Operating Mode	108
11 TIMER/COUNTER T2/T3/T4	110
11.1 T2/3/4-related Registers	110

11.2 Timer 2	111
11.3 Timer 3	115
11.4 Timer 4	119
11.5 Timer 2/3/4 Operating Modes.....	122
11.5.1 Timer 2/3/4 Operating Modes	123
12 PWM2/3/4	128
12.1 PWM2/3/4 related Registers	128
12.2 PWM2/3/4 Duty Variation Characteristics.....	132
12.3 PWM2/3/4 Cycle Variation Characteristics	132
13 PWM0	133
13.1 PWM Structure Diagram.....	133
13.2 PWM0 General Configuration Register.....	135
13.2.1 PWM0 General Configuration Register	135
13.2.2 PWM0 Fault Detection Function Setting.....	141
13.3 PWM0 Independent Mode	144
13.3.1 PWM0 Independent Mode Block Diagram	144
13.3.2 PWM0 Independent Mode Duty Cycle Configuration	145
13.4 PWM0 Complementary Model	146
13.4.1 PWM0 Block Diagram of Complementary Mode	146
13.4.2 PWM Complementary Mode Duty Cycle Configuration	146
13.4.3 PWM Complementary Mode Dead Time Setting.....	148
13.4.4 PWM0 Dead Zone Output Waveform.....	148
13.5 PWM0 Waveforms and Directions.....	149
14 GENERAL-PURPOSE I/O (GPIO).....	151
14.1 GPIO Structure Diagram.....	151
14.2 I/O Port-related Registers.....	153
15 LCD/LED DISPLAY DRIVER	163
15.1 LCD/LED Display Drive-related Registers	163
15.2 LCD/LED Display RAM Configuration.....	167
15.3 LCD Waveform	169
15.3.1 1/3Bias LCD Waveform	169
15.3.2 1/4Bias LCD Waveform	171
15.4 LED Waveform	173
15.5 LCD/LED Example.....	173
15.5.1 LCD Configuration Demo Program.....	173
15.5.2 LED Configuration Demo Program.....	174
16 SERIAL INTERFACE (UART0).....	175
16.1 Baud Rate of Serial Communication.....	177
17 SPI/TWI/UART SERIAL INTERFACE (USCI)	179
17.1 SPI	183

17.1.1 SPI Operation Related Registers	184
17.1.2 Signal Description	188
17.1.3 Operating Modes	189
17.1.4 Transfer Form	190
17.1.5 Error Detection	191
17.2 TWI	191
17.2.1 Signal Description	197
17.2.2 Slave Operating Mode	198
17.2.3 Slave Mode Operation Steps	200
17.2.4 Master operating Mode	201
17.2.5 Master Mode Operation Steps	202
17.3 Serial Interface (UART)	204
18 HIGH-SPEED ANALOG-TO-DIGITAL CONVERTER (ADC)	208
18.1 ADC-related Registers	208
18.2 ADC Conversion Steps	214
19 ANALOG COMPARATOR	216
19.1 Block Diagram of Analog Comparator	216
20 HIGH SENSITIVITY TOUCHKEY CIRCUITS	220
20.1 Power Consumption of TouchKey Circuits	220
21 CRC MODULE	221
21.1 CRC Check Operation Related Registers	222
22 MULTIPLIER-DIVIDER UNIT (MDU)	228
23 ELECTRICAL CHARACTERISTICS	231
23.1 Absolute Maximum Ratings	231
23.2 Recommended Operating Conditions	231
23.3 Flash ROM Characteristics	232
23.4 DC Characteristics	232
23.5 AC Characteristics	238
23.6 ADC Characteristics	238
23.7 Analog Comparator Characteristics	240
24 APPLICATION CIRCUIT	241
25 PACKAGE INFORMATION	242
26 REVISION HISTORY	253
IMPORTANT NOTICE	254

3 Pin Description

3.1 Pin Configuration

Note: In consideration of multiplexing of TK9/TK11 and TK debugging communication ports of the SC95F861XB, if it is required to use the TK debugging function, please avoid using TK9/TK11!

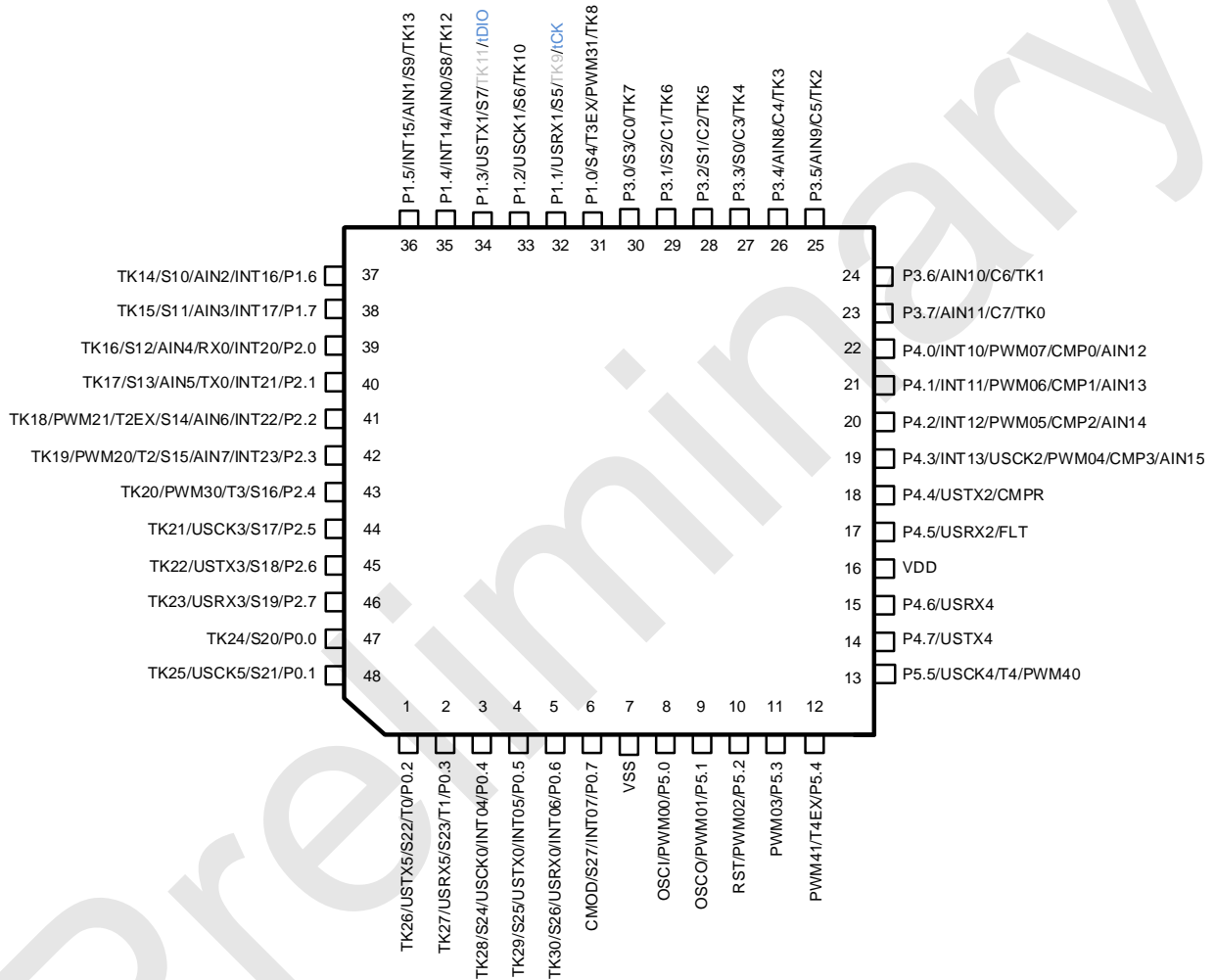

SC95F8617B Pin Diagram

Suitable for LQFP48 package

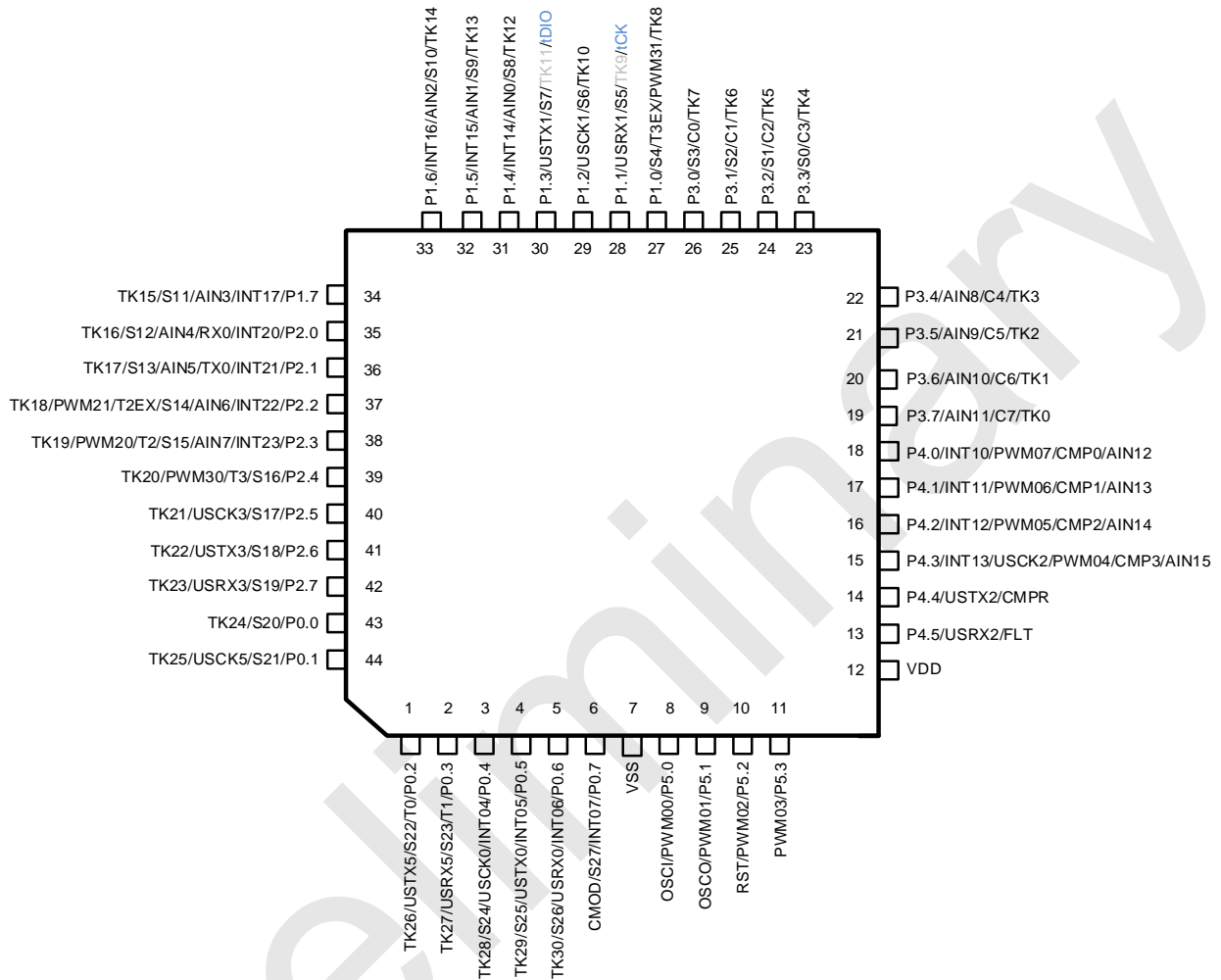

SC95F8616B Pin Diagram

Suitable for LQFP44 package

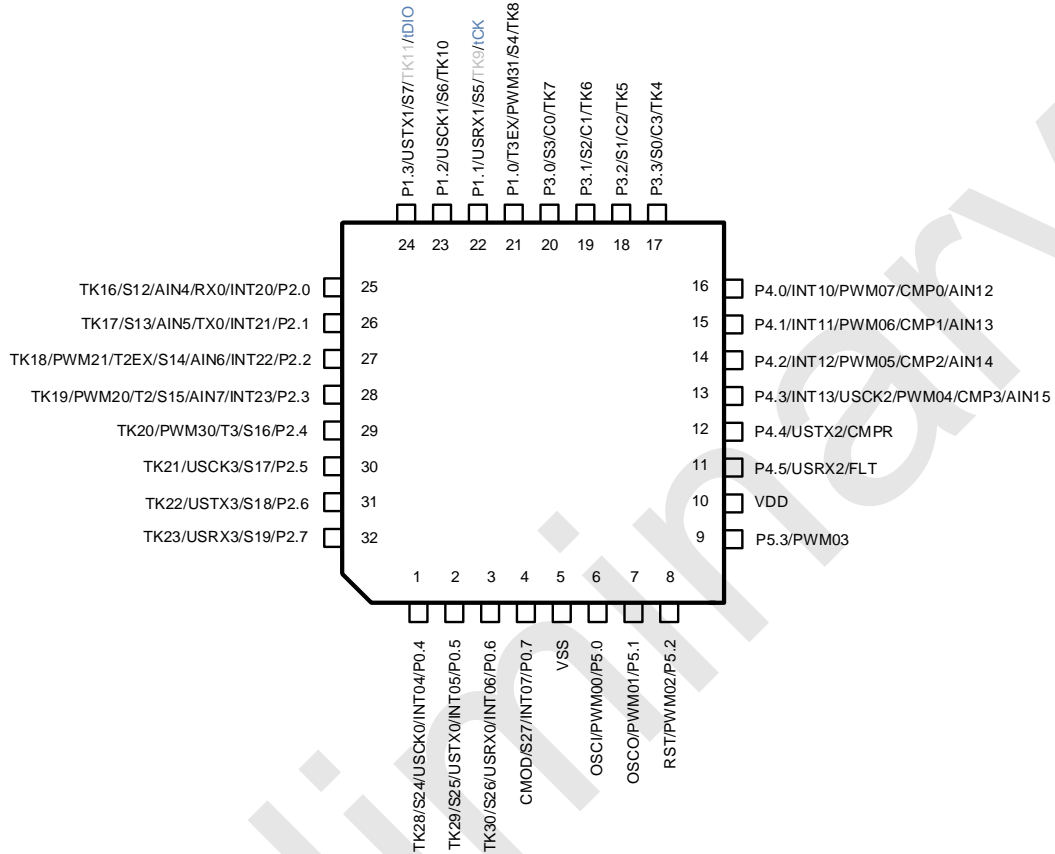

SC95F8615B Pin Diagram

Suitable for LQFP32 package

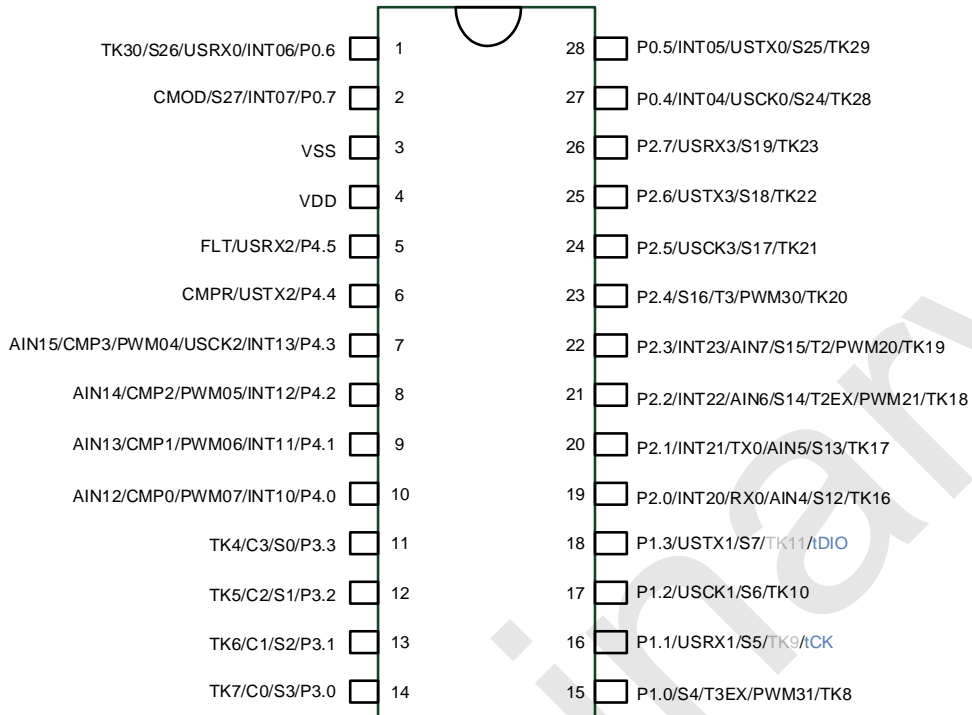

SC95F8613B Pin Diagram

Suitable for SOP28 and TSSOP28 package

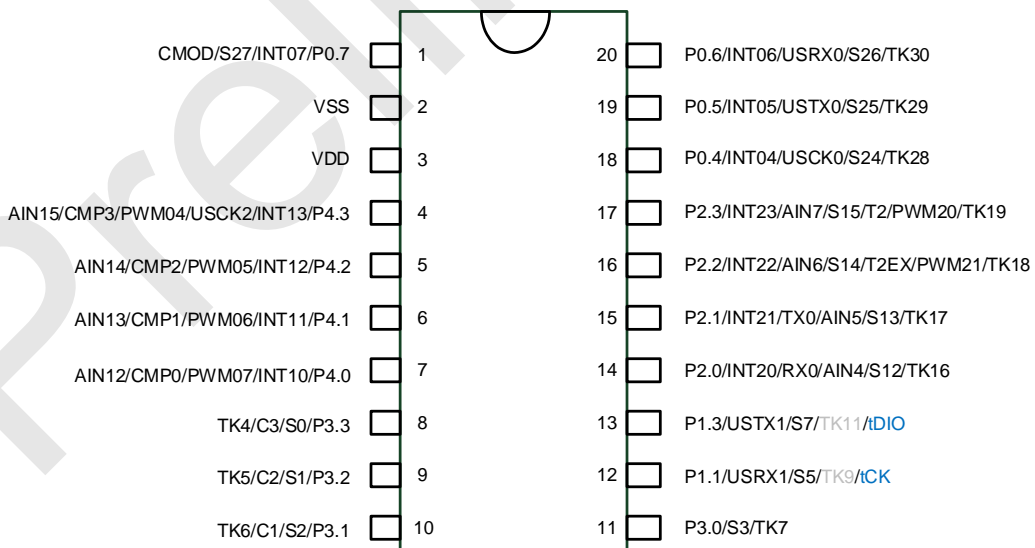

SC95F8612B Pin Diagram

Suitable for SOP20 and TSSOP20 package

3.1.1 48/44 Pin Definition

Pin number					Pin Name	Type	Description
48	44	32	28	20			
1	1	-	-	-	P0.2/T0/S22/USTX5/TK26	I/O	P0.2: GPIO P0.2 T0: Timer/Counter 0 External Input S22: LCD/LED SEG22 USTX5: USCI5 MOSI/SDA/TX TK26: TK Channel 26
2	2	-	-	-	P0.3/T1/S23/USRX5/TK27	I/O	P0.3: GPIO P0.3 T1: Timer/Counter 1 External Input S23: LCD/LED SEG23 USRX5: USCI5 MISO/RX TK27: TK Channel 27
3	3	1	27	18	P0.4/INT04/ USCK0/S24/TK28	I/O	P0.4: GPIO P0.4 INT04: Input 4 of external interrupt 0USCK0: USCI0 SCK S24: LCD/LED SEG24 TK28: TK Channel 28
4	4	2	28	19	P0.5/INT05/ USTX0/S25/TK29	I/O	P0.5: GPIO P0.5 INT05: Input 5 of external interrupt 0USTX0: USCI0 MOSI/SDA/TX S25: LCD/LED SEG25 TK29: TK Channel 29
5	5	3	1	20	P0.6/INT06/USRX0/S26/TK 30	I/O	P0.6: GPIO P0.6 INT06: Input 6 of external interrupt 0 USRX0: USCI0 MISO/RX

							S26: LCD/LED SEG26 TK30: TK Channel 30
6	6	4	2	1	P0.7/INT07/S27/CMOD	I/O	P0.7: GPIO P0.7 INT07: Input 7 of external interrupt 0 S27: LCD/LED SEG27 CMOD: Touch Key external capacitance
7	7	5	3	2	VSS	Power	Ground
8	8	6	-	-	P5.0/PWM00/OSCI	I/O	P5.0: GPIO P5.0 PWM00: PWM00 Output OSCI: 32K oscillator output
9	9	7	-	-	P5.1/PWM01/OSCO	I/O	P5.1: GPIO P5.1 PWM01: PWM01 Output OSCO: 32K oscillator output
10	10	8	-	-	P5.2/PWM02/RST	I/O	P5.2: GPIO P5.2 PWM02: PWM02 Output RST: Reset pin
11	11	9	-	-	P5.3/PWM03	I/O	P5.3: GPIO P5.3 PWM03: PWM03 Output
12	-	-	-	-	P5.4/T4EX/PWM41	I/O	P5.4: GPIO P5.4 T4EX: External capture for Timer4 PWM41: PWM41 Output
13	-	-	-	-	P5.5/USCK4/T4/PWM40	I/O	P5.5: GPIO P5.5 USCK4: USCI4 SCK T4: Timer/Counter4 external input

							PWM40: PWM40 Output
14	-	-	-	-	P4.7/USTX4	I/O	P4.7: GPIO P4.7 USTX4: USCI4 MOSI/SDA/TX
15	-	-	-	-	P4.6/USRX4	I/O	P4.6: GPIO P4.6 USRX4: USCI4 MISO/RX
16	12	10	4	3	VDD	Power	Power
17	13	11	5	-	P4.5/USRX2/FLT	I/O	P4.5: GPIO P4.5 USRX2: MISO/RX of USCI2 FLT: PWM1 fault detection input pin
18	14	12	6	-	P4.4/USTX2/CMPR	I/O	P4.4: GPIO P4.4 USTX2: MOSI/SDA/TX of USCI2 CMPR: The reference voltage of comparator input.
19	15	13	7	4	P4.3/INT13/USCK2/PWM04/CMP3/AIN15	I/O	P4.3: GPIO P4.3 INT13: Input 3 of external interrupt 1 USCK2: SCK of USCI2 PWM04: PWM04 Output CMP3: Analog comparator input channel 3 AIN15: ADC input channel 15
20	16	14	8	5	P4.2/INT12/PWM05/CMP2/AIN14	I/O	P4.2: GPIO P4.2 INT12: Input 2 of external interrupt 1 PWM05: PWM05 Output CMP2: Analog comparator input channel 2 AIN14: ADC input channel 14

21	17	15	9	6	P4.1/INT11/PWM06/CMP1/ AIN13	I/O	P4.1: GPIO P4.1 INT11: Input 1 of external interrupt 1 PWM06: PWM06 Output CMP1: Analog comparator input channel 1 AIN13: ADC input channel 13
22	18	16	10	7	P4.0/INT10/PWM07/CMP0/ AIN12	I/O	P4.0: GPIO P4.0 INT10: Input 0 of external interrupt 1 PWM07: PWM07 Output CMP0: Analog comparator input channel 0 AIN12: ADC input channel 12
23	19	-	-	-	P3.7/AIN11/C7/TK0	I/O	P3.7: GPIO P3.7 AIN11: ADC Input Channel 11 C7: LCD/LED common output 7 TK0: TK Channel 0
24	20	-	-	-	P3.6/AIN10/C6/TK1	I/O	P3.6: GPIO P3.6 AIN10: ADC input channel 10 C6: LCD/LED common output 6 TK1: TK Channel 1
25	21	-	-	-	P3.5/AIN9/C5/TK2	I/O	P3.5: GPIO P3.5 AIN9: ADC input channel 9 C5: LCD/LED common output 5 TK2: TK Channel 2
26	22	-	-	-	P3.4/AIN8/C4/TK3	I/O	P3.4: GPIO P3.4 AIN9: ADC input channel 8

							C4: LCD/LED common output 4 TK3: TK Channel 3
27	23	17	11	8	P3.3/S0/C3/TK4	I/O	P3.3: GPIO P3.3 S0: LCD/LED SEG 0 C3: LCD/LED common output 3 TK4: TK Channel 4
28	24	18	11	8	P3.2/S1/C2/TK5	I/O	P3.2: GPIO P3.2 S1: LCD/LED SEG 1 C2: LCD/LED common output 2 TK5: TK Channel 5
29	25	19	13	10	P3.1/S2/C1/TK6	I/O	P3.1: GPIO P3.1 S2: LCD/LED SEG 2 C1: LCD/LED common output 1 TK6: TK Channel 6
30	26	20	14	11	P3.0/S3/C0/TK7	I/O	P3.0: GPIO P3.0 S3: LCD/LED SEG 3 C0: LCD/LED common output 0 TK7: TK Channel 7
31	27	21	15	-	P1.0/S4/T3EX/PWM31/TK8	I/O	P1.0: GPIO P1.0 S4: LCD/LED SEG 4 T3EX: External capture for Timer3 PWM31: PWM31 Output TK8: TK Channel 8
32	28	22	16	12	P1.1/USRX1/S5/TK9/TK	I/O	P1.1: GPIO P1.1 USRX1: MISO/RX of USCI1

							<p>S5: LCD/LED SEG 5</p> <p>TK9: TK Channel 9, if it is required to use the TK debugging function, please avoid using TK9!</p> <p>tCK: Programming and Emulation Clock Pin</p>
33	29	23	17	-	P1.2/USCK1/S6/TK10	I/O	<p>P1.2: GPIO P1.2</p> <p>USCK1: SCK of USCI1</p> <p>S6: LCD/LED SEG 6</p> <p>TK10: TK Channel 10</p>
34	30	24	18	13	P1.3/USTX1/S7/TK11/tDIO	I/O	<p>P1.3: GPIO P1.3</p> <p>USTX1: MOSI/SDA/TX of USCI1</p> <p>S7: LCD/LED SEG 7</p> <p>TK11: TK channel 11, if it is required to use the TK debugging function, please avoid using TK11</p> <p>tDIO: Programming and Emulation Data Pin</p>
35	31	-	-	-	P1.4/INT14/AIN0/S8/TK12	I/O	<p>P1.4: GPIO P1.4</p> <p>INT14: Input 4 of external interrupt 1</p> <p>AIN0: ADC input channel 0</p> <p>S8: LCD/LED SEG 8</p> <p>TK12: TK Channel 12</p>
36	32	-	-	-	P1.5/INT15/AIN1/S9/TK13	I/O	<p>P1.5: GPIO P1.5</p> <p>INT15: Input 5 of external interrupt 1</p> <p>AIN1: ADC input channel 1</p> <p>S9: LCD/LED SEG 9</p> <p>TK13: TK Channel 13</p>
37	33	-	-	-	P1.6/INT16/AIN2/S10/TK14	I/O	<p>P1.6: GPIO P1.6</p> <p>INT16: Input 6 of external interrupt 1</p>

							AIN2: ADC Input Channel 2 S10: LCD/LED SEG10 TK14: TK Channel 14
38	34	-	-	-	P1.7/INT17/AIN3/S11/TK15	I/O	P1.7: GPIO P1.7 INT17: Input 7 of external interrupt 1 AIN3: ADC Input Channel 3 S11: LCD/LED SEG11 TK15: TK Channel 15
39	35	25	19	14	P2.0/INT20/RX0/AIN4/S12/TK16	I/O	P2.0: GPIO P2.0 INT20: Input 0 of external interrupt 2 RX0: UART0 Receiver AIN4: ADC Input Channel 4 S12: LCD/LED SEG12 TK16: TK Channel 16
40	36	26	20	15	P2.1/INT21/TX0/AIN5/S13/TK17	I/O	P2.1: GPIO P2.1 INT21: Input 1 of external interrupt 2 TX0: UART0 Transmitter AIN5: ADC Input Channel 5 S13: LCD/LED SEG13 TK17: TK Channel 17
41	37	27	21	16	P2.2/INT22/AIN6/S14/T2EX/PWM21/TK18	I/O	P2.2: GPIO P2.2 INT22: Input 2 of external interrupt 2 AIN6: ADC Input Channel 6 S14: LCD/LED SEG14 T2EX: External capture for Timer2 PWM21: PWM21 Output TK18: TK Channel 18
42	38	28	22	17	P2.3/INT23/AIN7/S15/T2/PWM20/TK19	I/O	P2.3: GPIO P2.3 INT23: Input 3 of external interrupt 2

							AIN7: ADC Input Channel 7 S15: LCD/LED SEG15 T2: Timer/Counter2 external input PWM20: PWM20 Output TK19: TK Channel 19
43	39	29	23	-	P2.4/S16/T3/PWM30/TK20	I/O	P2.4: GPIO P2.4 S16: LCD/LED SEG 16 T3: Timer/Counter3 external input PWM30: PWM30 Output TK20: TK Channel 20
44	40	30	24	-	P2.5/S17/USCK3/TK21	I/O	P2.5: GPIO P2.5 S17: LCD/LED SEG 17 USCK3:USCI3 SCK TK21: TK Channel 21
45	41	31	25	-	P2.6/S18/USTX3/TK22	I/O	P2.6: GPIO P2.6 S18: LCD/LED SEG 18 USTX3: USCI3 MOSI/SDA/TX TK22: TK Channel 22
46	42	32	26	-	P2.7/S19/USRX3/TK23	I/O	P2.7: GPIO P2.7 S19: LCD/LED SEG 19 USRX3: USCI3 MISO/RX TK23: TK Channel 23
47	43	-	-	-	P0.0/S20/TK24	I/O	P0.0: GPIO P0.0 S20: LCD/LED SEG 20 TK24: TK Channel 24
48	44	-	-	-	P0.1/S21/USCK5/TK25	I/O	P0.1: GPIO P0.1 S21: LCD/LED SEG 21 USCK5: USCI5 SCK

							TK25: TK Channel 25
--	--	--	--	--	--	--	---------------------

Preliminary

4 Inner Block Diagram

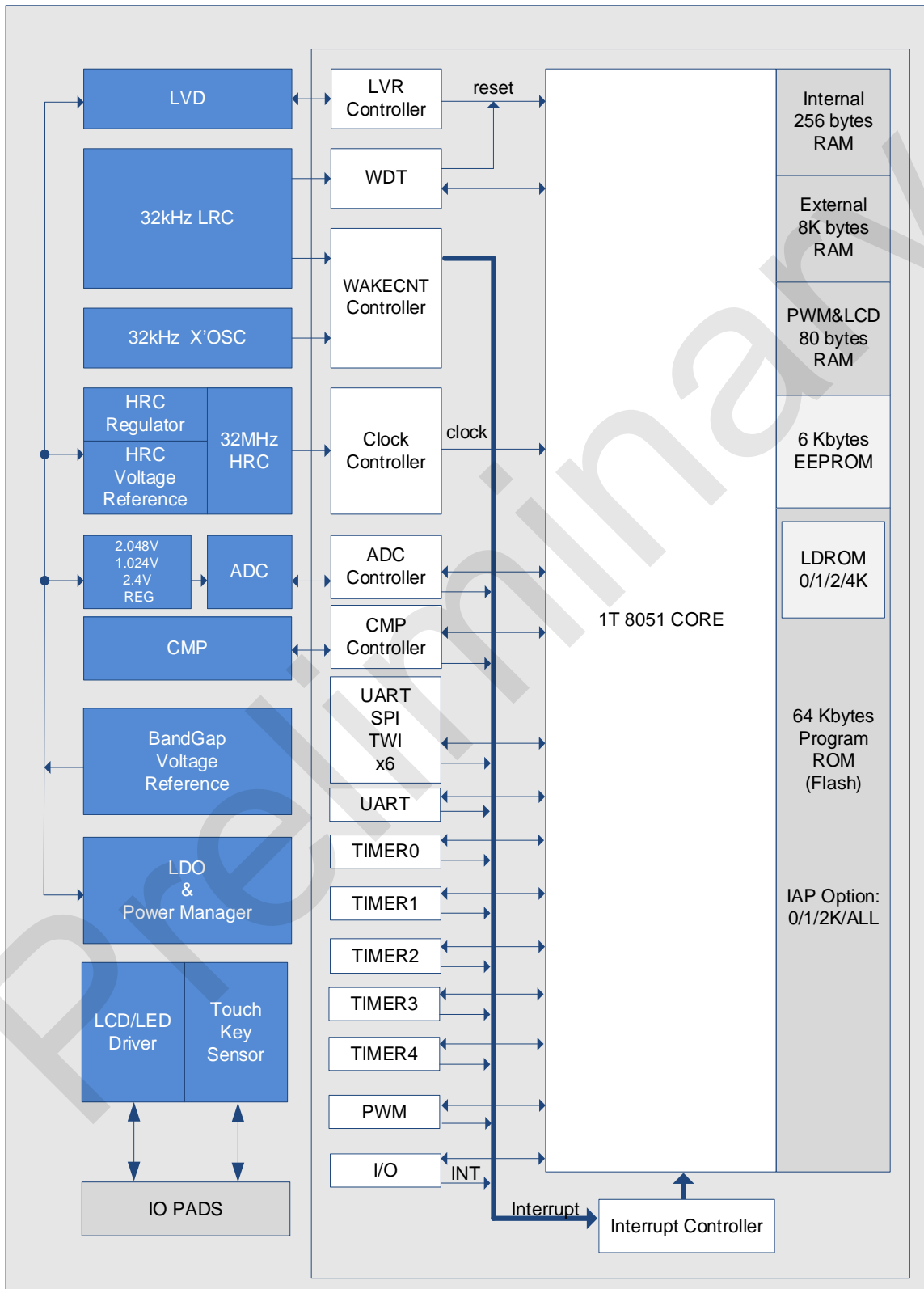

SC95F861XB BLOCK DIAGRAM

5 Flash ROM and SRAM

The Flash ROM of SC95F861XB is divided into five regions: APROM/LDROM/EEPROM/User ID/Unique ID, as shown in the following figure:

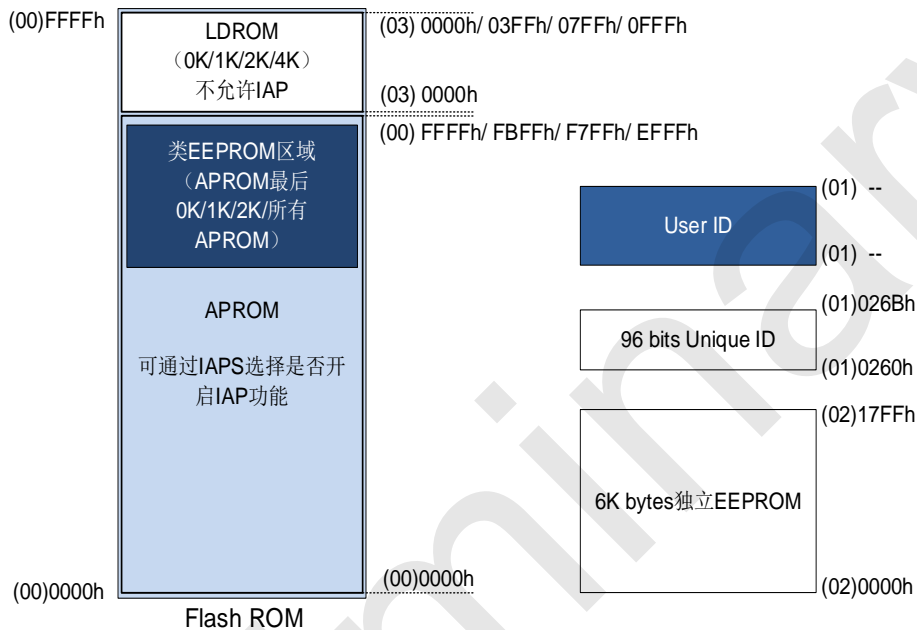

5.1 APROM and LDROM

APROM and LDROM are two independent pieces of hardware that divide ROM by LDSIZE[1:0]. They are distinguished by the extended address "00" and "03" set by IAPADE register. They can be programmed and erased by SC LINK PRO .

- The extended address of the APROM area is "00". The maximum size of the area is 64 Kbytes. It supports IAP (In Application Programming) and APROM area allowed IAP operation in Flash can be set to 0K/1K/2K/All APROM by Code Option.
- The extended address of LDROM area is "03", area size 0~4 Kbytes optional. IAP on LDROM is not allowed.

The SC95F861XB has 64 Kbytes of Flash ROM, the address is (00)0000H ~ (00)FFFFH, "00" in brackets is the extended address, which is set by the IAPADE register. Flash ROM can be programmed and erased by SC LINK PRO provided by SinOne. The characteristics of this 64 Kbytes Flash ROM are as follows:

- Divided into 128 sectors, 512 bytes per sector
- Can be rewritten 100,000 times
- The data written-in has more than 100-year preservation life in the ambient temperature of 25°C

- In ICP mode, BLANK, PROGRAM, VERIFY, ERASE and READ functions are supported. The READ function is only valid for ICs with no security encryption function enabled
- Secure Encryption: Optionally enable APROM (64 Kbytes Flash ROM) and LDROM secure encryption
- Support IAP (In Application Programming).

5.1.1 Flash ROM Sectors

The SC95F861XB has 64 Kbytes of Flash ROM divided into 128 sectors, each sector is 512 bytes, the sector to which the target address belongs will be forcibly erased by the programmer during writing, and then write data; When the user writes, must erasing it before writing.

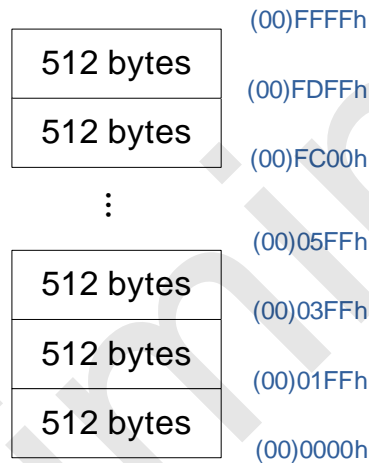

SC95F861XB 64 Kbytes Flash ROM Sectors

5.2 6K bytes independent EEPROM

The SC95F861XB has 6 Kbytes of independent EEPROM, the address is (02)000H ~ 17FFH, "02" in brackets is the extended address, which is set by the IAPADE register. Independent EEPROM can be rewritten 100,000 times and the data written-in has more than 100-year preservation life in the ambient temperature of 25°C . EEPROM supports blank checking, programming, verification, erasing and reading functions.

EEPROM divided into 12 sectors, 512 bytes per sector

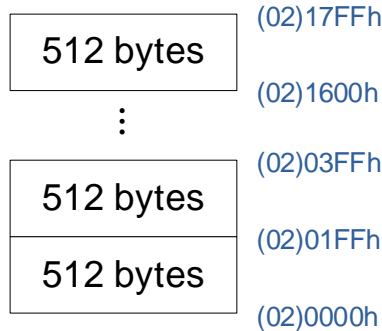

SC95F861XB EEPROM Sectors

Notes: EEPROM can be rewritten 100,000 times. User should not exceed the rated burn times of EEPROM, otherwise there will be exceptions!

5.3 96 bits Unique ID Area

The SC95F861XB provides an independent Unique ID area. A 96-bit unique code can be pre-programmed before leaving the factory to ensure the uniqueness of the chip. The only way for the user to obtain the serial number is to read the relative address (01)0260H~(01)026BH through the IAP instruction. The Unique ID range is (01)0260H ~ (01)026BH, the "01" in brackets indicates the extended address which is set by the IAPADE register. The specific operation method is as follows:

IAPADE (F4H) IAP Write to extended address register (Read/Write)

Bit number	7	6	5	4	3	2	1	0
Bit Mnemonic	IAPADER[7: 0]							
R/W	R/W	R/W	R/W	R/W	R/W	R/W	R/W	R/W
POR	0	0	0	0	0	0	0	0

Bit number	Bit Mnemonic	Description
7~0	IAPADER[7: 0]	<p>IAP Extended address:</p> <p>0x00: Both MOVC and IAP are for APROM</p> <p>0x01: For the unique ID area, read and write operations are not allowed, otherwise it may cause an exception!</p> <p>0x02: Both MOVC and IAP are for EEPROM</p> <p>0x03: This parameter takes effect only when the LDROM program is operating. Programs running in the LDROM region are allowed to perform MOVC operations on the LDROM program region. Note: LDROM operation permission is only for MOVC operation, prohibit IAP operation on LDROM, otherwise it will cause unpredictable exceptions!</p> <p>Other: reserved</p>

5.3.1 Unique ID Read Operating Demo Program In C Language

```

#include "intrins.h"

unsigned char UniqueID [12]; //store UniqueID

unsigned char code * POINT =0x0260;

unsigned char i;

EA = 0;           // Disable the global interrupt

IAPADE = 0X01;           // Expand address 0x01, select Unique ID area

for(i=0;i<12;i++)
{
    UniqueID [i]= *( POINT+i);           // Read the value of UniqueID
}

IAPADE = 0X00;           // Expand address 0x00, return to Code area

EA = 1;           // Enable global interrupt

```

5.4 User ID Area

User ID area, whose extended address is (01), is written for user in the factory. Users can read the User ID area, but cannot write the User ID area.

5.5 Programming

The SC95F861XB's Flash ROM can be programmed through tDIO, tCK, VDD, VSS, the specific connection relationship is as follows:

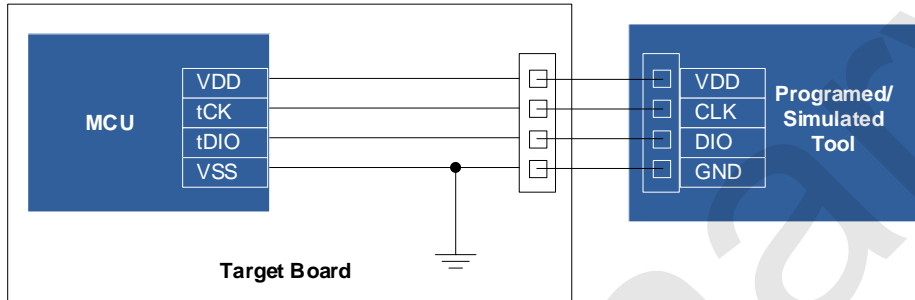

ICP mode Flash Writer programming connection diagram

tDIO,tCK is a 2-wire JTAG programming and emulation signal line. Users can configure the mode of these two ports through the Code Option when programming: JTAG Specific Mode and Normal Mode (JTAG specific port is invalid).

5.5.1 JTAG Specific Mode

tDIO,tCK are specific port for programming and emulation, and other functions multiplexed with it are not available. This mode is generally used in the online debugging stage, which is convenient for users to simulate and debug. After the JTAG special mode takes effect, the chip can directly enter the programming or emulation mode without powering on and off again.

5.5.2 Normal Mode (JTAG specific port is invalid)

The JTAG function is not available, and other functions multiplexed with it can be used normally. This mode can prevent the programming port from occupying the MCU pins, which is convenient for users to maximize the use of MCU resources.

Note: When the invalid configuration setting of the JTAG dedicated port is successful, the chip must be completely powered off and then on again to enter the programming or emulation mode, which will affect the programming and emulation in the live mode. SinOne recommends that users select the invalid configuration of the JTAG dedicated port during mass production and programming, and select the JTAG mode during the development and debugging phase.

Code Option register:

OP_CTM1 (C2H@FFH) Code Option register1 (read/write)

Bit number	7	6	5	4	3	2	1	0
-------------------	----------	----------	----------	----------	----------	----------	----------	----------

Bit Mnemonic	VREFS[1: 0]		OP_BL	DISJTG	IAPS[1: 0]		LDSIZE[1:0]	
R/W	R/W	R/W	R/W	R/W	R/W	R/W	R	
POR	n	n	n	n	n	n	n	n

Bit number	Bit Mnemonic	Description
4	DISJTG	IO/JTAG port switching control 0 : JTAG mode is enabled, P1.1 and P1.3 can only be used as tCK/tDIO. Recommended settings during R&D and commissioning 1 : Normal mode (Normal), JTAG function is invalid. The recommended setting for the mass production burning stage.

5.6 In Application Programming (IAP)

Application Programming (IAP) operations can be carried out in the APROM of SC95F861XB (0K, 1K, 2K, or all APROM ranges are optional) and 6K bytes EEPROM. Users can implement remote program updates through IAP operations. You can also obtain Unique ID field or User ID field information via IAP reads. Before IAPS write data, you must erase the Sector to which the target address belongs. The length of a Sector is 512 bytes. Flash ROM is divided into 128 sectors from (00)0000H to (00)FFFFH. The "00" in brackets is the expanded address set by the IAPADE register:

512 bytes	(00) FFFFh/ FBFFh/ F7FFh/ EFFFh
512 bytes	(00)FDFFh/ F9FFh/ F5FFh/ EDFHh
⋮	
512 bytes	(00)005FFh
512 bytes	(00)003FFh
512 bytes	(00)001FFh
512 bytes	(00)0000h

SC95F861XB 64 Kbytes Flash ROM Sectors

NOTE:

1. During the IAP erase/write process, the CPU holds the program counter, and after the IAP erase/write is complete, the program counter continues to execute subsequent instructions.
2. IAP operation in APROM area has certain risks, users need to take corresponding security measures in the software, if improper operation may cause user program rewriting! This feature is not recommended unless it is required by the user (for example, for remote application updates).
3. The EEPROM erasure count is 100,000. Do not exceed the rated EEPROM erasure count; otherwise, an exception may occur.

The user can select the IAP region range of APROM through Customer Option during programming, or set the IAP region of APROM through IAPS control bit in the program. The relevant registers are as follows: **OP_CTM1 (C2H@FFH) Code Option Register 1(Read/write)**

Bit number	7	6	5	4	3	2	1	0
Bit Mnemonic	VREFS[1: 0]		OP_BL	DISJTG	IAPS[1: 0]		LDSIZE[1:0]	
R/W	R/W	R/W	R/W	R/W	R/W	R/W	-R	
POR	n	n	n	n	n	n	n	n

Bit Number	Bit Mnemonic	Description
3~2	IAPS[1: 0]	<p>IAP spatial range selection</p> <p>00: Full Flash ROM not allows IAP operation</p> <p>01: Last 1K Flash ROM allows IAP operation</p> <p>10: Last 2K Flash ROM allows IAP operation</p> <p>11: Full Flash ROM allows IAP operation</p> <p>Note:</p> <p>1. The above setting items are invalid in BootLoader mode. The BootLoader program can perform IAP operation on the entire Flash ROM area.</p> <p>2. LDROM does not allow IAP operation under any circumstances.</p>

5.6.1 IAP Operation Related Register

Symbol	Address	Description	7	6	5	4	3	2	1	0	POR
IAPKEY	F1H	Data protection register	IAPKEY[7: 0]								0000000b
IAPADL	F2H	IAP write address low register	IAPADR[7: 0]								0000000b
IAPADH	F3H	IAP write address high register	IAPADR[15: 8]								0000000b
IAPADE	F4H	IAP write to extended address register	IAPADER[7: 0]								0000000b
IAPDAT	F5H	IAP data register	IAPDAT[7: 0]								0000000b
IAPCTL	F6H	IAP control register	BTL D	-	SERAS E	PRG	-	-	CMD[1: 0]		0x00xx00b

IAPKEY (F1H) Data Protection Register (Read/Write)

Bit number	7	6	5	4	3	2	1	0
Bit Mnemonic	IAPKEY[7: 0]							
R/W	R/W	R/W	R/W	R/W	R/W	R/W	R/W	R/W
POR	0	0	0	0	0	0	0	0

Bit Number	Bit Mnemonic	Description
------------	--------------	-------------

7~0	IAPKEY[7: 0]	<p>Open IAP function and operation time limit setting</p> <p>Write a value n greater than or equal to 0x40, which represents:</p> <p>1.Enable the IAP function;</p> <p>2.If no IAP write command is received after n system clocks, the IAP function is turned off again.</p>
-----	---------------------	---

IAPADL (F2H) IAP Write Address Low Register (read/write)

Bit number	7	6	5	4	3	2	1	0
Bit Mnemonic	IAPADR[7: 0]							
R/W	R/W	R/W	R/W	R/W	R/W	R/W	R/W	R/W
POR	0	0	0	0	0	0	0	0

Bit Number	Bit Mnemonic	Description
7~0	IAPADR[7: 0]	IAP writes the low 8 bits of the address

IAPADH (F3H) IAP Write Address High Register (read/write)

Bit number	7	6	5	4	3	2	1	0
Bit Mnemonic	IAPADR[15: 8]							
R/W	R/W	R/W	R/W	R/W	R/W	R/W	R/W	R/W
POR	0	0	0	0	0	0	0	0

Bit Number	Bit Mnemonic	Description
7~0	IAPADR[15: 8]	IAP writes the high 8 bits of the address

IAPADE (F4H) IAP Write to Extended Address Register (Read/Write)

Bit number	7	6	5	4	3	2	1	0
Bit Mnemonic	IAPADER[7: 0]							
R/W	R/W	R/W	R/W	R/W	R/W	R/W	R/W	R/W
POR	0	0	0	0	0	0	0	0

Bit Number	Bit Mnemonic	Description
7~0	IAPADER[7: 0]	<p>IAP extended address:</p> <p>0x00: Both MOVC and IAP are for code</p> <p>0x01: The Unique ID area is read but cannot be written 0x02: Both MOVC and IAP are for independent EEPROM</p> <p>0x03: MOVC is performed in the LDROM region (Note: only MOVC can be used, not IAP, this item is only valid for LDROM operation, APROM operation this item is not valid!)</p> <p>Other: reserved</p>

IAPDAT (F5H) IAP Data Register (read/write)

Bit number	7	6	5	4	3	2	1	0
Bit Mnemonic	IAPDAT[7: 0]							

R/W	R/W	R/W	R/W	R/W	R/W	R/W	R/W	R/W
POR	0	0	0	0	0	0	0	0

Bit number	Bit Mnemonic	R/W	Description
7~0	IAPDAT[7:0]	R/W	Data written by IAP

IAPCTL (F6H) IAP Control register (Read/Write)

Bit number	7	6	5	4	3	2	1	0
Bit Mnemonic	BTLD	-	SERASE	PRG	-	-	CMD[1: 0]	
R/W	R/W	-	R/W	R/W	-	-	R/W	R/W
POR	0	x	0	0	x	x	0	0

5.6.2 IAP Operation process

Please refer to the "SC95FXX6X_SC95FXX1XB IAP Operation Library Documentation Pack" for the IAP operation process of SC95F861XB.

5.6.3 IAP Operating Demo Program In C Language

The header files shared by the following routines are as follows:

```
#include "intrins.h"

unsigned int IAP_Add;

unsigned char IAP_Data;

unsigned char code * POINT =0x0000;
```

IAP operation: read data:

```
EA = 0;           // Close global interrupt

IAPADE = 0X00;    //The extended address is 0x00, selectFlash ROM

IAP_Data = *( POINT+IAP_Add); //Read the value of IAP_Add toIAP_Data

EA = 1;           // Open global interrupt
```

IAP operation: erase and write data:

Please refer to "SC95FXX6X_SC95FXX1XB IAP Operation Library Kit" if you want to implement IAP erasable operation.

5.6.4 IAP Operation notes

1. The user must erase the target sector before writing.
2. IAP operation in APROM area has certain risks, users need to take corresponding security measures in the software, if improper operation may cause user program rewriting! This feature is not recommended unless required (for remote application updates, for example);
3. When programming IC, if "APROM zone prevents IAP operation" is selected through Code Option, then IAPADE [7:0]=0x00 (APROM zone is selected), IAP cannot be operated, that is, data cannot be written, data can only be read by MOVC instruction;
4. When IAPADE is not 0x00, the MOVC and write target is non-APROM region. At this time, if there is an interrupt and MOVC operation occurs in the interrupt, the result of MOVC will be wrong and the program will run abnormally. To avoid this situation, if IAPADE is not 0x00 during IAP operation, it is important to turn off total interrupt (EA=0) before operation, and set IAPADE = 0x00 after operation before turning on total interrupt (EA=1);
5. During the IAP wipe/write process, the CPU holds the program counter, and the program counter only continues to execute subsequent instructions after the IAP wipe/write is complete;
6. The EEPROM erasure count is 100,000. Do not exceed the rated EEPROM erasure count; otherwise, an exception may occur!

5.7 BootLoader

The LDROM is used to store the bootLoader code. LDROM supports blank checking (BLANK), programming (PROGRAM), verifying (VERIFY), erasing (ERASE) and reading (READ) functions in ICP mode.

Users can realize ISP (In System Programming) function through LDROM: when ISP is executed, IC runs the boot code in LDROM area. When the boot code is executed, IC receives new program code through serial port, and then programs the received code into user code area through IAP command.

The LDROM has four address ranges:

- (03)0000H~(03)0000H (without LDROM)
- (03)0000H~(03)03FFH (1K)
- (03)0000H~(03)07FFH (2K)
- (03)0000H~(03)0FFFH (4K)

Where: "03" in the brackets above indicates the extended address, which is set by LDSIZE [1:0].

5.7.1 BootLoader Mode operation related registers

OP_CTM1 (C2H@FFH) Code Option Register1 (Read/Write)

Bit number	7	6	5	4	3	2	1	0
Bit Mnemonic	VREFS[1:0]		OP_BL	DISJTG	IAPS[1:0]		LDSIZE [1:0]	
R/W	R/W	R/W	R/W	R/W	R/W	R/W	Only read	
POR	n	n	n	n	n	n	n	n

Bit Number	Bit Mnemonic	Description
5	OP_BL	Program run area control bit 0: After the chip is reset, it enters APROM

		<p>1: After the chip is reset, it enters LDROM</p> <p>① The MOVC and IAP restrictions for APROM are as follows:</p> <table border="1" data-bbox="624 461 1436 797"> <thead> <tr> <th>Operation</th> <th>Is it operable?</th> </tr> </thead> <tbody> <tr> <td>LDROM MOVC</td> <td>x</td> </tr> <tr> <td>APROM MOVC</td> <td>Only the first 256 bytes cannot be MOVC</td> </tr> <tr> <td>LDROM IAP</td> <td>x</td> </tr> <tr> <td>APROM IAP</td> <td>√</td> </tr> </tbody> </table> <p>② The MOVC and IAP restrictions for LDROM are as follows:</p> <table border="1" data-bbox="624 896 1436 1234"> <thead> <tr> <th>Operation</th> <th>Is it operable?</th> </tr> </thead> <tbody> <tr> <td>LDROM MOVC</td> <td>√</td> </tr> <tr> <td>APROM MOVC</td> <td>√</td> </tr> <tr> <td>LDROM IAP</td> <td>x</td> </tr> <tr> <td>ALL APROM IAP, not restricted by IAPRANGE</td> <td>√</td> </tr> </tbody> </table>	Operation	Is it operable?	LDROM MOVC	x	APROM MOVC	Only the first 256 bytes cannot be MOVC	LDROM IAP	x	APROM IAP	√	Operation	Is it operable?	LDROM MOVC	√	APROM MOVC	√	LDROM IAP	x	ALL APROM IAP, not restricted by IAPRANGE	√
Operation	Is it operable?																					
LDROM MOVC	x																					
APROM MOVC	Only the first 256 bytes cannot be MOVC																					
LDROM IAP	x																					
APROM IAP	√																					
Operation	Is it operable?																					
LDROM MOVC	√																					
APROM MOVC	√																					
LDROM IAP	x																					
ALL APROM IAP, not restricted by IAPRANGE	√																					
1~0	LDSIZE [1:0]	<p>LDROM space range selection</p> <p>00: None LDROM, the APROM address is 0000H to FFFFH</p> <p>01: The last 1K APROM area of the Flash ROM is LDROM, and the APROM address is 0000H-FBFFh</p> <p>10: The last 2K APROM area of the Flash ROM is LDROM, and the APROM address is 0000H-F7FFh</p> <p>11: The last 4K APROM area of the Flash ROM is LDROM, and the APROM address is 0000H-FFFFh</p> <p>NOTE: LDROM not allow IAP operation in anyways</p>																				

IAPKEY (F1H) Data Protection Register (Read/Write)

Bit number	7	6	5	4	3	2	1	0
-------------------	----------	----------	----------	----------	----------	----------	----------	----------

Bit Mnemonic	IAPKEY[7: 0]							
R/W	R/W	R/W	R/W	R/W	R/W	R/W	R/W	R/W
POR	0	0	0	0	0	0	0	0

Bit number	Bit Mnemonic	Description
7~0	IAPKEY[7: 0]	Open IAP and operation time limit setting Write a value n greater than or equal to 0x40, which represents: <ol style="list-style-type: none"> 1. Enable the IAP; 2. If no IAP write command is received after n system clocks, the IAP is turned off again.

IAPADL (F2H) IAP Write Low Address Register (Read/Write)

Bit number	7	6	5	4	3	2	1	0
Bit Mnemonic	IAPADR[7: 0]							
R/W	R/W	R/W	R/W	R/W	R/W	R/W	R/W	R/W
POR	0	0	0	0	0	0	0	0

Bit number	Bit Mnemonic	Description
7~0	IAPADR[7: 0]	IAP writes the low 8 bits of the address

IAPADH (F3H) IAP Write High Address Register (Read/Write)

Bit number	7	6	5	4	3	2	1	0
Bit Mnemonic	IAPADR[15: 8]							
R/W	R/W	R/W	R/W	R/W	R/W	R/W	R/W	R/W
POR	0	0	0	0	0	0	0	0

Bit number	Bit Mnemonic	Description
7~0	IAPADR[15: 8]	IAP writes the upper 8 bits of the address

IAPADE (F4H) IAP Write to Extended Address Register (Read/Write)

Bit number	7	6	5	4	3	2	1	0
Bit Mnemonic	IAPADER[7: 0]							
R/W	R/W	R/W	R/W	R/W	R/W	R/W	R/W	R/W
POR	0	0	0	0	0	0	0	0

Bit number	Bit Mnemonic	Description
7~0	IAPADER[7: 0]	IAP extended address: 0x00: Both MOV C and IAP are for Flash ROM 0x01: The Unique ID area is read but cannot be written 0x02: Both MOV C and IAP are for independent EEPROM

		0x03: MOVC is performed in the LDROM region (Note: only MOVC can be used, not IAP, this item is only valid for LDROM operation, APROM operation this item is not valid!) Other: reserved
--	--	--

IAPDAT (F5H) IAP Data Register (Read/Write)

Bit number	7	6	5	4	3	2	1	0
Bit Mnemonic	IAPDAT[7: 0]							
R/W	R/W	R/W	R/W	R/W	R/W	R/W	R/W	R/W
POR	0	0	0	0	0	0	0	0

Bit number	Bit Mnemonic	Description
7~0	IAPDAT[7:0]	Data written by IAP

IAPCTL (F6H) IAP Control Register (Read/Write)

Bit number	7	6	5	4	3	2	1	0
Bit Mnemonic	BTLD	-	SERASE	PRG	-	-	CMD[1: 0]	
R/W	R/W	-	R/W	R/W	-	-	R/W	R/W
POR	0	x	0	0	x	x	0	0

Bit number	Bit Mnemonic	Description
------------	--------------	-------------

7	BTLD	BootLoader control bit 0: The program starts to run from the main program area (main program) after Reset; 1: The program starts to run from the BootLoader area after Reset
---	-------------	--

PCON (87h) Power Management Control Register (write only, *not readable*)

Bit number	7	6	5	4	3	2	1	0
Bit Mnemonic	SMOD	-	-	-	RST	-	STOP	IDL
R/W	write only	-	-	-	write only	-	write only	write only
POR	0	x	x	x	n	x	0	0

Bit number	Bit Mnemonic	Description
3	RST	Software reset control bit: Write status: 0: The program runs normally; 1: The CPU resets immediately after this bit is written to "1"

Bootloader Notes:

1. The user must erase the target sector before writing LDR0M;
2. For the specific operation method, please refer to the description document " SinOne hardware BootLoader Function Implementation Application Guide" provided by SinOne.

5.8 Encryption

Users can choose whether to encrypt the SC95F861XB's ROM through the settings on the computer program:

1. If the encryption function is disabled, users can read the last data written in APROM and LDROM by SC LINK;
2. If the encryption function is enabled, the data written in APROM (64 Kbytes Flash ROM) and LDROM will never be read from outside. It is recommended to enable the encryption function during mass production;
3. The only way to release security encryption is to re-programming
4. The encryption has no effect on iap read and write operation

For the specific operation method, please refer to the chapter of Secure Encryption and Reading in the "SOC LINK Series Programmer & Simulator User Manual".

5.9 Code Option Area (User Programming Settings)

Symbol	OPINX Address	Instructions	bit7	bit6	bit5	bit4	bit3	bit2	bit1	bit0
OP_CTM0	C1H@FFH	Code Option register 0	ENWDT	ENXTL	SCLKS[1:0]		DISRST	DISLVR	LVRS[1:0]	
OP_CTM1	C2H@FFH	Code Option register 1	VREFS[1:0]		OPBL	DISJTG	IAPS[1:0]		LDSIZE[1:0]	
OP_HRCR	83H@FFH	System clock change register	OP_HRCR[7:0]							

IFB Address	Symbol	Write read	Instructions
OP_CTM0[7]	ENWDT	R/W	WDT Switch 0: WDT invalid 1: WDT valid(WDT stops counting during IAP execution)
OP_CTM0[6]	ENXTL	R/W	External 32K crystal selector switch 0: External 32K crystal Interface disable, P5.0 and P5.1 valid 1: External 32K crystal Interface enable, P5.0 and P5.1 invalid
OP_CTM0[5~4]	SCLKS [1:0]	R/W	System clock frequency selection bits 00: System clock frequency is HRC frequency divided by 1; 01: System clock frequency is HRC frequency divided by 2; 10: System clock frequency is HRC frequency divided by 4; 11: System clock frequency is HRC frequency divided by 8;

OP_CTM0[3]	DISRST	Read only	IO/RST Selection bit 0: configure P5.2 as External Reset input pin 1: configure P5.2 as GPIO						
OP_CTM0[2]	DISLVR	R/W	LVR control bit 0: LVR valid 1: LVR invalid						
OP_CTM0[1~0]	LVRS [1:0]	R/W	LVR voltage selection control 11: 4.3V reset 10: 3.7V reset 01: 2.9V reset 00: 1.9V reset						
OP_CTM1[7~6]	VREFS [1:0]	R/W	Reference voltage selection 00: Configure ADC VREF as VDD; 01: Configure ADC VREF as internal 2.048V 10: Configure ADC VREF as internal 1.024V 11: Configure ADC VREF as internal 2.4V						
OP_CTM1[5]	OP_BL	R/W	Program run area control bit 0: After the chip is reset, it enters APROM 1: After the chip is reset, it enters LDROM 1. The MOV C and IAP restrictions for APROM are as follows: <table border="1" data-bbox="608 1756 1444 2038"> <thead> <tr> <th>Operation</th> <th>Is it operable?</th> </tr> </thead> <tbody> <tr> <td>LDROM MOV C</td> <td>x</td> </tr> <tr> <td>APROM MOV C</td> <td>Only the first 256 bytes cannot be MOV C</td> </tr> </tbody> </table>	Operation	Is it operable?	LDROM MOV C	x	APROM MOV C	Only the first 256 bytes cannot be MOV C
Operation	Is it operable?								
LDROM MOV C	x								
APROM MOV C	Only the first 256 bytes cannot be MOV C								

			<table border="1"> <tr> <td>LDRON IAP</td> <td>x</td> </tr> <tr> <td>APROM IAP</td> <td>√</td> </tr> </table> <p>2. The MOVN and IAP restrictions for LDRON are as follows:</p> <table border="1"> <thead> <tr> <th>Operation</th> <th>Is it operable?</th> </tr> </thead> <tbody> <tr> <td>LDRON MOVN</td> <td>√</td> </tr> <tr> <td>APROM MOVN</td> <td>√</td> </tr> <tr> <td>LDRON IAP</td> <td>x</td> </tr> <tr> <td>ALL APROM IAP, not restricted by IAPRANGE</td> <td>√</td> </tr> </tbody> </table>	LDRON IAP	x	APROM IAP	√	Operation	Is it operable?	LDRON MOVN	√	APROM MOVN	√	LDRON IAP	x	ALL APROM IAP, not restricted by IAPRANGE	√
LDRON IAP	x																
APROM IAP	√																
Operation	Is it operable?																
LDRON MOVN	√																
APROM MOVN	√																
LDRON IAP	x																
ALL APROM IAP, not restricted by IAPRANGE	√																
OP_CTM1[4]	DISJTG	R/W	IO/JTAG Port switching control 0: JTAG mode is enabled, P1.1 and P1.3 can only be used as tCK/tDIO. 1: Normal mode (Normal), JTAG function is invalid.														
OP_CTM1[3~2]	IAPS[1:0]	R/W	IAP spatial range selection 00: All Flash ROM not allows IAP operation 01: Last 1K Flash ROM allows IAP operation 10: Last 2K Flash ROM allows IAP operation 11: All Flash ROM allows IAP operation Note: 1. The preceding Settings are invalid in BootLoader mode, and the BootLoader program can perform IAP operations on the entire APROM region 2. LDRON does not allows IAP operation														
OP_CTM1[1:0]	LDSIZE[1:0]	Read only	LDRON space range selection 00: None LDRON, the APROM address is 0000H to FFFFH														

			<p>01: The last 1K APROM area of the Flash ROM is LDROM, and the APROM address is 0000H-FBFFh</p> <p>10: The last 2K APROM area of the Flash ROM is LDROM, and the APROM address is 0000H-F7FFh</p> <p>11: The last 4K APROM area of the Flash ROM is LDROM, and the APROM address is 0000H-EFFFh</p> <p>NOTE: LDROM not allow IAP operation in anyways</p>																
OP_HRCR	OP_HRCR[7:0]	R/W	<p>HRC frequency change register</p> <p>User can change the high-frequency oscillator frequency f_{HRC} by modifying the value of this register, and then change the system clock frequency f_{sys}:</p> <ol style="list-style-type: none"> The initial value of OP_HRCR[7: 0] after power-on OP_HRCR[s] is a fixed value to ensure that f_{HRC} is 32MHz, OP_HRCR[s] of each IC may be different When the initial value is OP_HRCR[s], the system clock frequency f_{sys} of the IC can be set to an accurate 32/16/8/4MHz through the Option item. When OP_HRCR [7: 0] changes by 1, the f_{sys} frequency changes by about 0.18% <p>The relationship between OP_HRCR [7: 0] and f_{sys} output frequency is as follows:</p> <table border="1"> <thead> <tr> <th>OP_HRCR [7: 0] Value</th> <th>f_{sys} actual output frequency (32M as an example)</th> </tr> </thead> <tbody> <tr> <td>OP_HRCR [s]-n</td> <td>$32000*(1-0.18\%*n)$kHz</td> </tr> <tr> <td>...</td> <td>....</td> </tr> <tr> <td>OP_HRCR [s]-2</td> <td>$32000*(1-0.18\%*2) = 31\ 884.8$kHz</td> </tr> <tr> <td>OP_HRCR [s]-1</td> <td>$32000*(1-0.18\%*1) = 31\ 942.4$kHz</td> </tr> <tr> <td>OP_HRCR [s]</td> <td>32000kHz</td> </tr> <tr> <td>OP_HRCR [s]+1</td> <td>$32000*(1+0.18\%*1) = 32\ 057.6$kHz</td> </tr> <tr> <td>OP_HRCR [s]+2</td> <td>$32000*(1+0.18\%*2) = 32\ 115.2$kHz</td> </tr> </tbody> </table>	OP_HRCR [7: 0] Value	f_{sys} actual output frequency (32M as an example)	OP_HRCR [s]-n	$32000*(1-0.18\%*n)$ kHz	OP_HRCR [s]-2	$32000*(1-0.18\%*2) = 31\ 884.8$ kHz	OP_HRCR [s]-1	$32000*(1-0.18\%*1) = 31\ 942.4$ kHz	OP_HRCR [s]	32000kHz	OP_HRCR [s]+1	$32000*(1+0.18\%*1) = 32\ 057.6$ kHz	OP_HRCR [s]+2	$32000*(1+0.18\%*2) = 32\ 115.2$ kHz
OP_HRCR [7: 0] Value	f_{sys} actual output frequency (32M as an example)																		
OP_HRCR [s]-n	$32000*(1-0.18\%*n)$ kHz																		
...																		
OP_HRCR [s]-2	$32000*(1-0.18\%*2) = 31\ 884.8$ kHz																		
OP_HRCR [s]-1	$32000*(1-0.18\%*1) = 31\ 942.4$ kHz																		
OP_HRCR [s]	32000kHz																		
OP_HRCR [s]+1	$32000*(1+0.18\%*1) = 32\ 057.6$ kHz																		
OP_HRCR [s]+2	$32000*(1+0.18\%*2) = 32\ 115.2$ kHz																		

		
			OP_HRCR [s]+n	32000*(1+0.18%*n)kHz
		<p>Note:</p> <ol style="list-style-type: none"> 1. The OP_HRCR[7:0] value of IC after each power-on is the value of the high-frequency oscillator frequency fHRC closest to 32MHz; The user corrects the HRC value after each power-on so that the IC's system clock frequency fSYS works at the user's desired frequency; 2. In order to ensure the reliable operation of IC, the highest operating frequency of IC should not exceed 10% of 32MHz, i.e. 35.2MHz; 3. Confirm that the change of HRC frequency will not affect other functions. 		

5.9.1 Customer-Option-related Registers Operation Instructions

Option-related SFRs reading and writing operations are controlled by both OPINX and OPREG registers, with their respective position of Option SFR depending on OPINX and its value written to option-related SFR depending on register OPREG:

Symbol	Address	Instructions		POR
OPINX	FEH	Option pointer	OPINX[7: 0]	00000000b
OPREG	FFH	Option register	OPREG[7: 0]	nnnnnnnb

The OPINX register stores the address of the related OPTION register when operating the Option related SFR, and the OPREG register stores the corresponding value.

For example: To set ENWDT (OP_CTM0.7) to 1, the specific operation method is as follows:

C language example:

```
OPINX = 0xC1;           // Write the address of OP_CTM0 to the OPINX register
OPREG |= 0x80;         // Set 1 for OP_CTM0.7
```

Assembly language example:

MOV OPINX,#C1H ; Write the address of OP_CTM0 to the OPINX register

ORL OPREG,#80H ; Set 1 for OP_CTM0.7

Note: It is forbidden to write any value beyond SFR address of Customer Option region into OPINX register! Or else, it may cause abnormal system operation.

5.10 SRAM

The SRAM structure of the SC95F861XB is as follows:

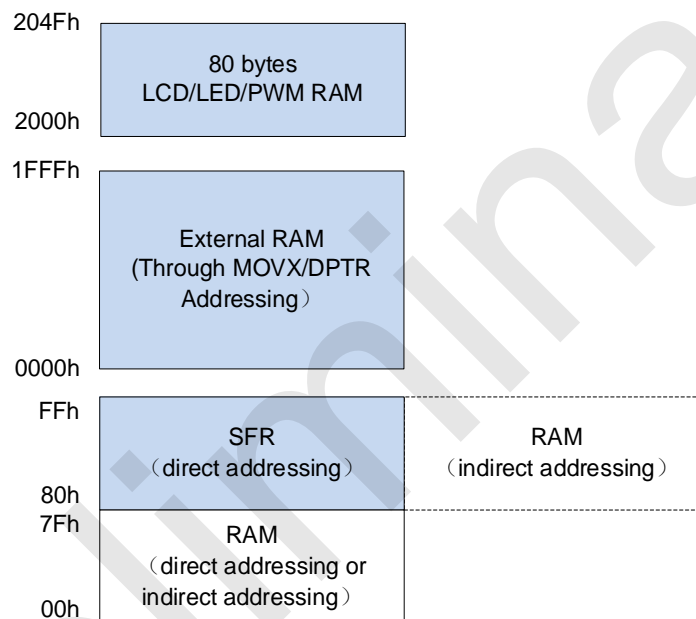

The SRAM of the SC95F861XB MCU is divided into internal 256 bytes RAM, external 8192 bytes RAM and 80 bytes PWM&LCD RAM. The address range of the internal RAM is 00H~FFH, where the high 128 bytes (address 80H~FFH) can only be indirectly addressed, and the low 128 bytes (address 00H~7FH) can be directly or indirectly addressed.

The address of the special function register SFR is also 80H~FFH. But the difference between SFR and internal high 128 bytes SRAM is: SFR register is directly addressed, while internal high 128 bytes SRAM can only be indirectly addressed.

The address of the external RAM is 0000H~1FFFFH, but it needs to be addressed by the MOVX instruction.

5.10.1 Internal 256 Bytes SRAM

The internal low 128 bytes SRAM area can be divided into three parts:

① Operating register group 0~3, address 00H~1FH, the combination of RS0 and RS1 in the program status word register PSW determines the operating register currently used, using operating register group 0~ 3 can speed up the operation;

- ② Bit addressing area 20H~2FH, this area can be used as ordinary RAM or bit-wise addressing RAM; when addressing by bit, the bit address is 00H~7FH, (The address is programmed bit by bit, which is different from the general SRAM coded by byte), which can be distinguished by instructions in the program;
- ③ User RAM and stack area, after the SC95F861XB is reset, the 8-bit stack pointer points to the stack area. Users generally set the initial value during initialization. It is recommended to set the initial value between E0H ~ FFH..

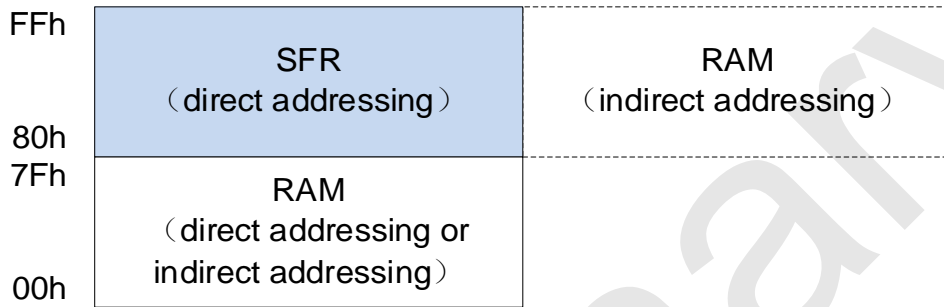

Internal 256 bytes RAM structure diagram

The internal low 128 bytes RAM structure is as follows:

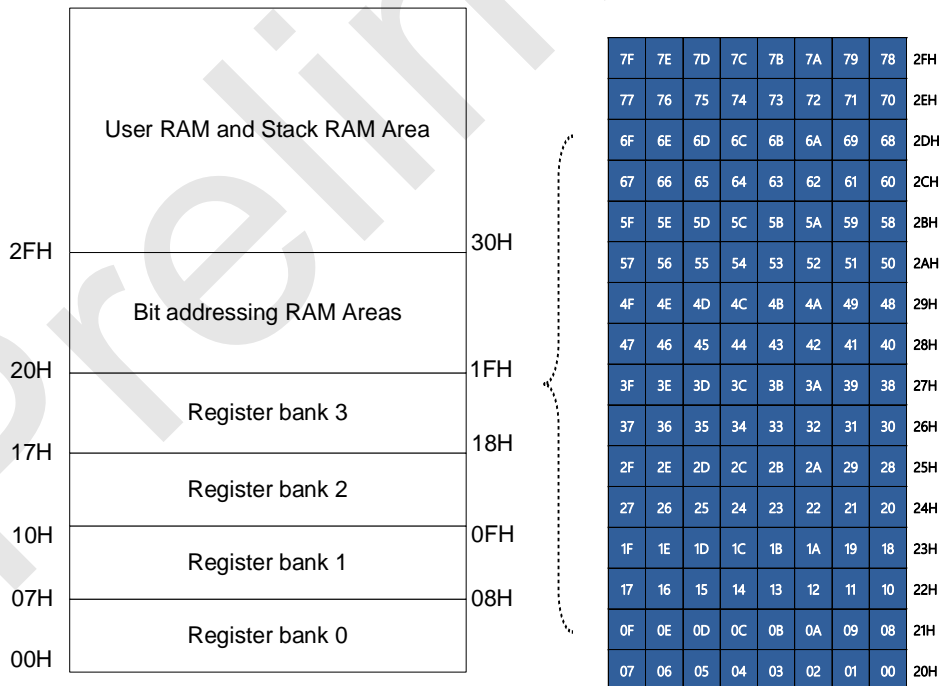

SRAM structure diagram

5.10.2 External 8 Kbytes SRAM

External 8192 bytes RAM can be accessed through MOVX @DPTR, A; you can also use MOVX A, @Ri or MOVX @Ri, A with EXADH register to access external 8192 bytes RAM: EXADH register stores the high address of external SRAM, Ri register stores the low 8 bits of the external SRAM.

EXADH (F7H) External SRAM Operation Address High Bit (read/write)

Bit number	7	6	5	4	3	2	1	0
Bit Mnemonic	-	-	-	EXADH [4: 0]				
POR	x	x	x	0	0	0	0	0

Bit number	Bit Mnemonic	Description
4~0	EXADH [4: 0]	High-bit of external SRAM operation address
7~5	-	reserved

5.10.3 External 80 bytes PWM&LCD/LED SRAM

The 2000H~204FH of the RAM address are used as PWM&LCD/LED SRAM of 80 bytes, among them:

1. The PWM duty cycle adjustment register occupies 2034H~204FH and can **be read and written.**;
2. LCD/LED display RAM occupies 2000H~201BH and can **be read and written.**

6 Special Function Register (SFR)

6.1 SFR Mapping

The SC95F861XB provides some registers equipped with special functions, called SFR. The addresses of these registers are located at 80H~FFH, some are bit-addressable, and others are not. It is very convenient for these bit addressable registers to change the value of single bit, of which the address is end up with figure "0" or "8". All SFR shall use direct addressing for addressing.

The SC95F861XB SFR Map is as follows:

	0/8	1/9	2/A	3/B	4/C	5/D	6/E	7/F
F8h	-	-	-	BTMCON	CRCINX	CRCREG	OPINX	OPREG
F0h	B	IAPKEY	IAPADL	IAPADH	IAPADE	IAPDAT	IAPCTL	EXADH
E8h	-	EXA0	EXA1	EXA2	EXA3	EXBL	EXBH	OPERCON
E0h	ACC	-	-	-	-	-	-	-
D8h	P5	P5CON	P5PH	-	USXINX	-	-	-
D0h	PSW	PWMCFG	PWMCON0	PWMCON1	PWMPDL	PWMPDH	PWMDFR	PWMFLT
C8h	TXCON	TXMOD	RCAPXL	RCAPXH	TLX	THX	TXINX	WDTCON
C0h	P4	P4CON	P4PH	-	USXCON0	USXCON1	USXCON2	USXCON3
B8h	IP	IP1	IP2	INT0R	INT1F	INT1R	INT2F	INT2R
B0h	P3	P3CON	P3PH	P3VO	INT0F	ADCCFG2	CMPCFG	CMPCON
A8h	IE	IE1	IE2	ADCCFG0	ADCCFG1	ADCCON	ADCVL	ADCVH
A0h	P2	P2CON	P2PH	P2VO	US1CON0	US1CON1	US1CON2	US1CON3
98h	SCON	SBUF	P0CON	P0PH	P0VO	US0CON1	US0CON2	US0CON3

90h	P1	P1CON	P1PH	DDRCON	P1VO	US0CON0	IOHCON0	IOHCON1
88h	TCON	TMOD	TL0	TL1	TH0	TH1	TMCON	OTCON
80h	P0	SP	DPL	DPH	DPL1	DPH1	DPS	PCON
	Bit addressable	Non-bit addressable						

Note: The empty part of the SFR register are not recommended for users.

6.2 SFR Instructions

6.2.1 SFR

SFR specific explanations are as follows:

Mnemonic	Add	Description	7	6	5	4	3	2	1	0	POR
P0	80H	P0 port data register	P07	P06	P05	P04	P03	P02	P01	P00	0000000b
SP	81H	Stack pointer	SP[7: 0]								0000111b
DPL	82H	DPTR data pointer low	DPL[7: 0]								0000000b
DPH	83H	DPTR data pointer high	DPH[7: 0]								0000000b
DPL1	84H	DPTR1 data pointer low	DPL1[7: 0]								0000000b
DPH1	85H	DPTR1 data pointer high	DPH1[7: 0]								0000000b
DPS	86H	DPTR selection register	ID1	ID0	TSL	AU1	AU0	-	-	SEL	0000xx0b
PCON	87H	Power management control register	SMOD	-	-	-	RST	-	STOP	IDL	0xx0x00b
TCON	88H	Timer control register	TF1	TR1	TF0	TR0	IE1	-	IE0	-	0000x0xb

TMOD	89H	Timer operating mode register	-	C/T1	M11	M01	-	C/T0	M10	M00	x000x000b
TL0	8AH	Low 8 bits of timer 0	TL0[7: 0]								00000000b
TL1	8BH	Low 8 bits of timer 1	TL1[7: 0]								00000000b
TH0	8CH	Timer 0 high 8 bits	TH0[7: 0]								00000000b
TH1	8DH	Timer 1 high 8 bits	TH1[7: 0]								00000000b
TMCON	8EH	Timer frequency control register	USMDX[1: 0]	-	-	-	-	T1FD	T0FD	00xxxx00b	
OTCON	8FH	Output control register	USMD1[1: 0]	USMD0[1: 0]		VOIRS[1: 0]		SCS	BIAS	00000000b	
P1	90H	P1 port data register	P17	P16	P15	P14	P13	P12	P11	P10	00000000b
P1CON	91H	P1 port input/output control register	P1C7	P1C6	P1C5	P1C4	P1C3	P1C2	P1C1	P1C0	00000000b
P1PH	92H	P1 port pull-up resistor control register	P1H7	P1H6	P1H5	P1H4	P1H3	P1H2	P1H1	P1H0	00000000b
DDRCON	93H	Display drive control register	DDR0N	DMOD	DUTY[1: 0]		VLCD[3: 0]			00000000b	
P1VO	94H	P1 port display driver output register	P17VO	P16VO	P15VO	P14VO	P13VO	P12VO	P11VO	P10VO	00000000b
US0CON0	95H	USC10 control register 0	US0CON0[7: 0]								00000000b
IOHCON0	96H	IOH setting register 0	P1H[1: 0]		P1L[1: 0]		P0H[1: 0]		P0L[1: 0]		00000000b
IOHCON1	97H	IOH setting register 1	-	-	P3L[1: 0]		P2H[1: 0]		P2L[1: 0]		xx000000b
SCON	98H	Serial control register	SM0	SM1	SM2	REN	TB8	RB8	TI	RI	00000000b
SBUF	99H	Serial data buffer register	SBUF[7: 0]								00000000b

P0CON	9AH	P0 port input/output control register	P0C7	P0C6	P0C5	P0C4	P0C3	P0C2	P0C1	P0C0	0000000b
P0PH	9BH	P0 port pull-up resistor control register	P0H7	P0H6	P0H5	P0H4	P0H3	P0H2	P0H1	P0H0	0000000b
P0VO	9CH	P0 port display driver output register	P07VO	P06VO	P05VO	P04VO	P03VO	P02VO	P01VO	P00VO	0000000b
US0CON1	9DH	USCI0 control register 1	US0CON1[7: 0]								0000000b
US0CON2	9EH	USCI0 control register 2	US0CON2[7: 0]								0000000b
US0CON3	9FH	USCI0 control register 3	US0CON3[7: 0]								0000000b
P2	A0H	P2 port data register	P27	P26	P25	P24	P23	P22	P21	P20	0000000b
P2CON	A1H	P2 port input/output control register	P2C7	P2C6	P2C5	P2C4	P2C3	P2C2	P2C1	P2C0	0000000b
P2PH	A2H	P2 port pull-up resistor control register	P2H7	P2H6	P2H5	P2H4	P2H3	P2H2	P2H1	P2H0	0000000b
P2VO	A3H	P2 port display driver output register	P27VO	P26VO	P25VO	P24VO	P23VO	P22VO	P21VO	P20VO	0000000b
US1CON0	A4H	USCI1 control register 0	US1CON0[7: 0]								0000000b
US1CON1	A5H	USCI1 control register 1	US1CON1[7: 0]								0000000b
US1CON2	A6H	USCI1 control register 2	US1CON2[7: 0]								0000000b
US1CON3	A7H	USCI1 control register 3	US1CON3[7: 0]								0000000b
IE	A8H	Interrupt enable register	EA	EADC	ET2	EUART	ET1	EINT1	ET0	EINT0	0000000b
IE1	A9H	Interrupt enable register 1	ET4	ET3	ECMP	ETK	EINT2	EBTM	EPWM	EUSCI0	0000000b

IE2	AAH	Interrupt enable register 2	-	-	-	EUSCI5	EUSCI4	EUSCI3	EUSCI2	EUSCI1	xxx00000b
ADCCFG0	ABH	ADC setting register 0	EAIN7	EAIN6	EAIN5	EAIN4	EAIN3	EAIN2	EAIN1	EAIN0	00000000b
ADCCFG1	ACH	ADC setting register 1	EAIN15	EAIN14	EAIN13	EAIN12	EAIN11	EAIN10	EAIN9	EAIN8	00000000b
ADCCON	ADH	ADC control register	ADCEN	ADCS	EOC/ADCIF	ADCIS[4: 0]				00000000b	
ADCVL	AEH	ADC Conversion Value Register	ADCV[3: 0]				-	-	-	-	1111xxxxb
ADCVH	AFH	ADC Conversion Value Register	ADCV[11: 4]							11111111b	
P3	B0H	P3 port data register	P37	P36	P35	P34	P33	P32	P31	P30	00000000b
P3CON	B1H	P3 port input/output control register	P3C7	P3C6	P3C5	P3C4	P3C3	P3C2	P3C1	P3C0	00000000b
P3PH	B2H	P3 port pull-up resistor control register	P3H7	P3H6	P3H5	P3H4	P3H3	P3H2	P3H1	P3H0	00000000b
P3VO	B3H	P3 port display driver output register	P37VO	P36VO	P35VO	P34VO	P33VO	P32VO	P31VO	P30VO	00000000b
INT0F	B4H	INT0 falling edge interrupt control register	INT0F7	INT0F6	INT0F5	INT0F4	-	-	-	-	0000xxxxb
ADCCFG2	B5H	ADC setting register 2	-	-	-	LOWSP[2: 0]			-	-	xxx000xxb
CMPCFG	B6H	Analog comparator setting register	-	-	-	CMPP	CMPIM[1: 0]		CMPIS[1: 0]		xxx00000b
CMPCON	B7H	Analog Comparator Control Register	CMPEN	CMPIF	CMPSTA	-	CMPRF[3: 0]				000x0000b
IP	B8H	Interrupt priority control register	-	IPADC	IPT2	IPUART	IPT1	IPINT1	IPT0	IPINT0	x0000000b
IP1	B9H	Interrupt priority control register 1	IPT4	IPT3	IPCMP	IPTK	IPINT2	IPBTM	IPPWM	IPSSIO	00000000b

IP2	BAH	Interrupt priority control register 2	-	-	-	IPUSCI5	IPUSCI4	IPUSCI3	IPUSCI2	IPUSCI1	xxx00000b
INT0R	BBH	INT0 rising edge interrupt control register	INT0R7	INT0R6	INT0R5	INT0R4	-	-	-	-	0000xxxxb
INT1F	BCH	INT1 falling edge interrupt control register	INT1F7	INT1F6	INT1F5	INT1F4	INT1F3	INT1F2	INT1F1	INT1F0	00000000b
INT1R	BDH	INT1 rising edge interrupt control register	INT1R7	INT1R6	INT1R5	INT1R4	INT1R3	INT1R2	INT1R1	INT1R0	00000000b
INT2F	BEH	INT2 falling edge interrupt control register	-	-	-	-	INT2F3	INT2F2	INT2F1	INT2F0	xxxx0000b
INT2R	BFH	INT2 rising edge interrupt control register	-	-	-	-	INT2R3	INT2R2	INT2R1	INT2R0	xxxx0000b
P4	C0H	P4 port data register	P47	P46	P45	P44	P43	P42	P41	P40	00000000b
P4CON	C1H	P4 port input/output control register	P4C7	P4C6	P4C5	P4C4	P4C3	P4C2	P4C1	P4C0	00000000b
P4PH	C2H	P4 port pull-up resistor control register	P4H7	P4H6	P4H5	P4H4	P4H3	P4H2	P4H1	P4H0	00000000b
USXCON0	C4H	USCI2/3/4/5 control register 0	USXCON0[7: 0]								00000000b
USXCON1	C5H	USCI2/3/4/5 control register 1	USXCON1[7: 0]								00000000b
USXCON2	C6H	USCI2/3/4/5 control register 2	USXCON2[7: 0]								00000000b
USXCON3	C7H	USCI2/3/4/5 control register 3	USXCON3[7: 0]								00000000b
TXCON	C8H	Timer 2/3/4 control register	TFX	EXFX	RCLKX	TCLKX	EXENX	TRX	C/TX	CP/RLX	00000000b
TXMOD	C9H	Timer 2/3/4 operating mode register	TXFD	-	EPWMN1	EPWMN0	INVN1	INVN0	TXOE	DCXEN	0x000000b

RCAPXL	CAH	Timer 2/3/4 reload low 8 bits	RCAPXL[7: 0]								0000000b
RCAPXH	CBH	Timer 2/3/4 reload high 8 bits	RCAPXH[7: 0]								0000000b
TLX	CCH	Timer 2/3/4 low 8 bits	TLX[7: 0]								0000000b
THX	CDH	Timer 2/3/4 high 8 bits	THX[7: 0]								0000000b
TXINX	CEH	Timer control register pointer	-	-	-	-	-	TXINX[2: 0]			xxxx010b
WDTCON	CFH	WDT control register	-	-	-	CLRWDT	-	WDTCKS[2: 0]			xxx0x000b
PSW	D0H	Program status word register	CY	AC	F0	RS1	RS0	OV	F1	P	0000000b
PWMCFG	D1H	PWM0 setting register	INV7	INV6	INV5	INV4	INV3	INV2	INV1	INV0	0000000b
PWMCON0	D2H	PWM0 control register0	ENPWM	PWMIF	PWMCK[1: 0]		-	-	PWMMD[1:0]		0000xx00b
PWMCON1	D3H	PWM0 control register 1	ENPWM7	ENPWM6	ENPWM5	ENPWM4	ENPWM3	ENPWM2	ENPWM1	ENPWM0	x0000000b
PWMPDL	D4H	PWM0 period register low 8 bits	PWMPDL[7:0]								0000000b
PWMPDH	D5H	PWM0 period register high 8 bits	PWMPDH[7:0]								0000000b
PWMDFR	D6H	PWM0 dead time setting register	PDF1[3: 0]				PDR1[3: 0]				0000000b
PWMFLT	D7H	PWM0 fault detection setting register	FLTEN1	FLTSTA1	FLTMD1	FLTLV1	-	-	FLTDT1[1: 0]		0000xx00b
P5	D8H	P5 port data register	-	-	P55	P54	P53	P52	P51	P50	xx000000b
P5CON	D9H	P5 port input/output control register	-	-	P5C5	P5C4	P5C3	P5C2	P5C1	P5C0	xx000000b
P5PH	DAH	P5 port pull-up resistor control register	-	-	P5H5	P5H4	P5H3	P5H2	P5H1	P5H0	xx000000b

USXINX	DCH	USCI2/3/4/5 Control register pointer	-	-	-	-	-	-	USCIX[2:0]	xxxx000b	
ACC	E0H	accumulator	ACC[7: 0]							0000000b	
EXA0	E9H	Extended Accumulator 0	EXA[7: 0]							0000000b	
EXA1	EAH	Extended Accumulator 1	EXA[15: 8]							0000000b	
EXA2	EBH	Extended Accumulator 2	EXA[23: 16]							0000000b	
EXA3	ECH	Extended Accumulator 3	EXA[31: 24]							0000000b	
EXBL	EDH	Extended B register L	EXB [7: 0]							0000000b	
EXBH	EEH	Extended B register H	EXB [15: 8]							0000000b	
OPERCON	EFH	Arithmetic control register	OPERS	MD	-	-	-	-	CRCRST	CRCSTA	00xxx00b
B	F0H	B register	B[7: 0]							0000000b	
IAPKEY	F1H	IAP protection register	IAPKEY[7: 0]							0000000b	
IAPADL	F2H	IAP write address low register	IAPADR[7: 0]							0000000b	
IAPADH	F3H	IAP write address high register	IAPADR[15: 8]							0000000b	
IAPADE	F4H	IAP write to extended address register	IAPADER[7: 0]							0000000b	
IAPDAT	F5H	IAP data register	IAPDAT[7: 0]							0000000b	
IAPCTL	F6H	IAP control register	BTLD	-	SERASE	PRG	-	-	CMD[1: 0]		0x00xx00b
EXADH	F7H	High-bit address of external SRAM operation address	-	-	-	EXADH [4: 0]				xxx0000b	

BTMCON	FBH	Low frequency timer control register	ENBTM	BTMIF	-	-	BTMFS[3: 0]	00xx0000b
CRCINX	FCH	CRC pointer	CRCINX[7: 0]					00000000b
CRCREG	FDH	CRC register	CRCREG[7: 0]					nnnnnnnbn
OPINX	FEH	Option pointer	OPINX[7: 0]					00000000b
OPREG	FFH	Option register	OPREG[7: 0]					nnnnnnnbn

6.2.2 PWM0 Duty Cycle Adjustment Register(R/W)

ADD	7	6	5	4	3	2	1	0	POR
2040H	PDT00[15:8]								00000000b
2041H	PDT00[7:0]								00000000b
2042H	PDT01[15:8]								00000000b
2043H	PDT01[7:0]								00000000b
2044H	PDT02[15:8]								00000000b
2045H	PDT02[7:0]								00000000b
2046H	PDT03[15:8]								00000000b
2047H	PDT03[7:0]								00000000b
2048H	PDT04[15:8]								00000000b
2049H	PDT04[7:0]								00000000b
204AH	PDT05[15:8]								00000000b
204BH	PDT05[7:0]								00000000b
204CH	PDT06[15:8]								00000000b
204DH	PDT06[7:0]								00000000b
204EH	PDT07[15:8]								00000000b
204FH	PDT07[7:0]								00000000b

6.2.3 PWM2~4 Duty Cycle Adjustment Register(R/W)

ADD	7	6	5	4	3	2	1	0	POR
2034H	PDT20[15:8]								00000000b
2035H	PDT20[7:0]								00000000b
2036H	PDT21[15:8]								00000000b
2037H	PDT21[7:0]								00000000b
2038H	PDT30[15:8]								00000000b
2039H	PDT30[7:0]								00000000b
203AH	PDT31[15:8]								00000000b
203BH	PDT31[7:0]								00000000b
203CH	PDT40[15:8]								00000000b
203DH	PDT40[7:0]								00000000b
203EH	PDT41[15:8]								00000000b
203FH	PDT41[7:0]								00000000b

6.2.4 LCD/LED display RAM configuration (R/W)

ADD	7	6	5	4	3	2	1	0
	COM7	COM6	COM5	COM4	COM3	COM2	COM1	COM0
2000H	SEG0	SEG0	SEG0	SEG0	SEG0	SEG0	SEG0	SEG0
2001H	SEG1	SEG1	SEG1	SEG1	SEG1	SEG1	SEG1	SEG1
2002H	SEG2	SEG2	SEG2	SEG2	SEG2	SEG2	SEG2	SEG2
2003H	SEG3	SEG3	SEG3	SEG3	SEG3	SEG3	SEG3	SEG3
2004H	SEG4	SEG4	SEG4	SEG4	SEG4	SEG4	SEG4	SEG4
2005H	SEG5	SEG5	SEG5	SEG5	SEG5	SEG5	SEG5	SEG5
2006H	SEG6	SEG6	SEG6	SEG6	SEG6	SEG6	SEG6	SEG6
2007H	SEG7	SEG7	SEG7	SEG7	SEG7	SEG7	SEG7	SEG7
2008H	SEG8	SEG8	SEG8	SEG8	SEG8	SEG8	SEG8	SEG8
2009H	SEG9	SEG9	SEG9	SEG9	SEG9	SEG9	SEG9	SEG9
200AH	SEG10	SEG10	SEG10	SEG10	SEG10	SEG10	SEG10	SEG10

ADD	7	6	5	4	3	2	1	0
	COM7	COM6	COM5	COM4	COM3	COM2	COM1	COM0
200BH	SEG11	SEG11	SEG11	SEG11	SEG11	SEG11	SEG11	SEG11
200CH	SEG12	SEG12	SEG12	SEG12	SEG12	SEG12	SEG12	SEG12
200DH	SEG13	SEG13	SEG13	SEG13	SEG13	SEG13	SEG13	SEG13
200EH	SEG14	SEG14	SEG14	SEG14	SEG14	SEG14	SEG14	SEG14
200FH	SEG15	SEG15	SEG15	SEG15	SEG15	SEG15	SEG15	SEG15
2010H	SEG16	SEG16	SEG16	SEG16	SEG16	SEG16	SEG16	SEG16
2011H	SEG17	SEG17	SEG17	SEG17	SEG17	SEG17	SEG17	SEG17
2012H	SEG18	SEG18	SEG18	SEG18	SEG18	SEG18	SEG18	SEG18
2013H	SEG19	SEG19	SEG19	SEG19	SEG19	SEG19	SEG19	SEG19
2014H	SEG20	SEG20	SEG20	SEG20	SEG20	SEG20	SEG20	SEG20
2015H	SEG21	SEG21	SEG21	SEG21	SEG21	SEG21	SEG21	SEG21
2016H	SEG22	SEG22	SEG22	SEG22	SEG22	SEG22	SEG22	SEG22
2017H	SEG23	SEG23	SEG23	SEG23	SEG23	SEG23	SEG23	SEG23
2018H	SEG24	SEG24	SEG24	SEG24	SEG24	SEG24	SEG24	SEG24
2019H	SEG25	SEG25	SEG25	SEG25	SEG25	SEG25	SEG25	SEG25
201AH	SEG26	SEG26	SEG26	SEG26	SEG26	SEG26	SEG26	SEG26
201BH	SEG27	SEG27	SEG27	SEG27	SEG27	SEG27	SEG27	SEG27

6.2.5 Introduction of Common Special Function Registers of 8051 Core

Program Counter PC

The program counter PC does not belong to the SFR register. The PC has 16 bits and is a register used to control the order of execution of instructions. After the MCU is powered on or reset, the PC value is 0000H, which means that the MCU program starts executing the program from the 0000H address.

Accumulator ACC (E0H)

The accumulator ACC is one of the most commonly used registers of the 8051 core single-chip microcomputer, and A is used as a mnemonic in the instruction set. Commonly used to store operands and results that participate in calculations or logical operations.

B Register (F0H)

The B register must be used with the accumulator A in multiplication and division operations. The multiplication instruction MUL A, B multiplies the 8-bit unsigned number in accumulator A and register B. The low-bit byte of the resulting 16-bit product is placed in A, and the high-bit byte is placed in B. The division instruction DIV A, B divides A by B, the integer quotient is placed in A, and the remainder is placed in B. Register B can also be used as a general temporary storage register.

Stack Pointer SP (81H)

The stack pointer is an 8-bit special register that indicates the location of the top of the stack in general-purpose RAM. After the Microcontroller unit (MCU) is reset, the initial value of SP is 07H, that is, the stack will increase upward from 08H. 08H~1FH is operating register group 1~3.

PSW (D0H) Program Status Word Register (read/write)

Bit number	7	6	5	4	3	2	1	0
Bit Mnemonic	CY	AC	F0	RS1	RS0	OV	F1	P
R/W	R/W	R/W	R/W	R/W	R/W	R/W	R/W	R/W
POR	0	0	0	0	0	0	0	0

Bit number	Bit Mnemonic	Description
7	CY	Flag 1: When there is a carry in the highest bit of addition, or a borrow in the highest bit of subtraction 0: When there is no carry in the highest bit of addition, or there is no borrow in the highest bit of subtraction
6	AC	Carry auxiliary flag (can be easily adjusted during the addition and subtraction of BCD code) 1: When the addition operation has a carry in bit3, or the subtraction operation has a borrow in bit3 0: No borrowing, carry
5	F0	User flag

4~3	RS1,RS0	Operating register group selection bits:		
		RS1	RS0	Operating register set currently in use 0~3
		0	0	TEAM 0 (00H~07H)
		0	1	TEAM 1 (08H~0FH)
		1	0	TEAM 2 (10H~17H)
		1	1	TEAM 3 (18H~1FH)
2	OV	Overflow flag		
1	F1	F1 flag User-defined flag		
0	P	Parity flag. This flag bit is the parity value of the number of 1s in the accumulator ACC. 1: The number of 1s in ACC is odd 0: The number of 1s in ACC is even (including 0)		

Data Pointers DPTR0 (82H, 83H), DPTR1 (84H, 85H) And Its Selection Register DPS (86H)

The SC95F861XB has two data pointers DPTR0 and DPTR1. Data pointers DPTR0/DPTR1 are 16-bit special registers, which are composed of low 8-bit DPL/DPL1 and high 8-bit DPH/DPH1. DPTR0/DPTR1 is a register that can directly perform 16-bit operations, and can also operate on DPL and DPH in bytes respectively. The selection and operating status of the data pointer DPTR0/DPTR1 are set by the data pointer selection register DPS.

DPS(86H)Data Pointer Selection Register (read/write)

Bit number	7	6	5	4	3	2	1	0
Bit Mnemonic	ID1	ID0	TSL	AU1	AU0	-	-	SEL

R/W	R/W	R/W	R/W	R/W	R/W	-	-	R/W
POR	0	0	0	0	0	x	x	0

Bit number	Bit Mnemonic	Description
7	ID1	<p>DPTR1 plus or minus control bit</p> <p>0: When AU1=1, whenever the MOVC/MOVX @DPTR is executed, the current DPTR1 will automatically increase by 1.</p> <p>1: When AU1=1, whenever MOVC/MOVX @DPTR is executed, the current DPTR1 will automatically decrease by 1.</p>
6	ID0	<p>DPTR plus or minus control bit</p> <p>0: When AU0=1, whenever MOVC/MOVX @DPTR is executed, the current DPTR0 will automatically increase by 1.</p> <p>1: When AU0=1, whenever MOVC/MOVX @DPTR is executed, the current DPTR0 will automatically decrease by 1.</p>
5	TSL	<p>SEL flip control bit</p> <p>0: Whenever MOVC/MOVX @DPTR is executed, DPS.0 (SEL) does not flip</p> <p>1: Whenever MOVC/MOVX @DPTR is executed, DPS.0 (SEL) flips once</p>
4	AU1	<p>DPTR1 automatic plus and minus control bit</p> <p>0: None</p> <p>1: Whenever MOVC/MOVX @DPTR is executed, the current DPTR1 will increase or decrease by 1 (depending on ID1)</p>
3	AU0	<p>DPTR automatic plus and minus control bit</p> <p>0: None</p> <p>1: Whenever MOVC/MOVX @DPTR is executed, the current DPTR0 will increase or decrease by 1 (depending on ID0)</p>

0	SEL	DPTR0, DPTR1 selection bits 0: MOVC/MOVX @DPTR object is DPTR0 1: MOVC/MOVX @DPTR object is DPTR1
2~1	-	reserved

Preliminary

7 Power, Reset And System Clock

7.1 Power Circuit

The SC95F861XB power supply system includes BG, LDO, POR, LVR and other circuits, which can achieve reliable operation in the range of 2.0~5.5V. In addition, the IC has a built-in, accurate 2.048V, 1.024V and 2.4V voltage that can be used as an internal reference voltage for the ADC. Users can find the specific settings in the [18 analog-to-digital converter \(ADC\)](#).

7.2 Power-on Reset

After the SC95F861XB power-on, the processes carried out before execution of client software are as follows:

- Reset stage
- Loading information stage
- Normal operation stage

7.2.1 Reset Stage

The SC95F861XB will always be reset until the voltage supplied to SC95F861XB is higher than a certain voltage, and the internal Clock starts to be effective. The duration of reset stage is related to rising speed of external power. Once the external supply voltage is up to built-in POR voltage, the reset stage would be completed.

7.2.2 Loading Information Stage

There is a warm-up counter inside The SC95F861XB. During the reset stage, the warm-up counter is cleared to 0 until the voltage exceeds the POR voltage, the internal RC oscillator starts to oscillate, and the warm-up counter starts counting. When the internal warm-up counter counts to a certain number, every certain number of HRC clocks will read a byte of data from the IFB (including Code Option) in the Flash ROM and store it in the internal system register. This reset signal will not end until the warm-up is completed.

7.2.3 Normal Operation Stage

After finishing the Loading Information stage, The SC95F861XB starts to read the instruction code from Flash and enters the normal operation stage. The LVR voltage is the set value of Code Option written by the user.

7.3 Reset Modes

The SC95F861XB has 5 reset methods, the first four are hardware reset:

1. External reset
2. Low-voltage reset LVR
3. Power-on reset POR
4. Watchdog WDT reset
5. Software reset.

The circuit diagram of the reset part of the SC95F861XB is as follows:

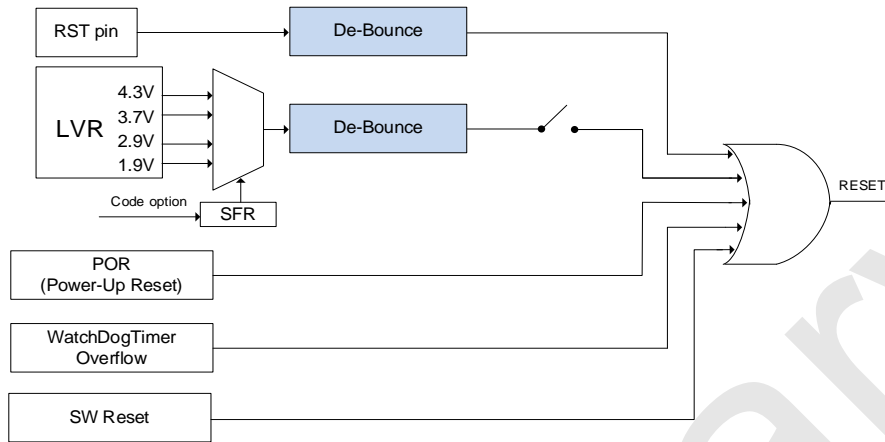

SC95F861XB Reset circuit diagram

After reset the boot area:

After the external RST reset, low voltage reset LVR, power-on reset POR, watchdog WDT, the chip starts from the boot region (APROM/LDROM) set by the user OP_BL.

After the software is reset, the chip is started according to the boot region (APROM/LDROM) set by BTLD (IAPCTL.7).

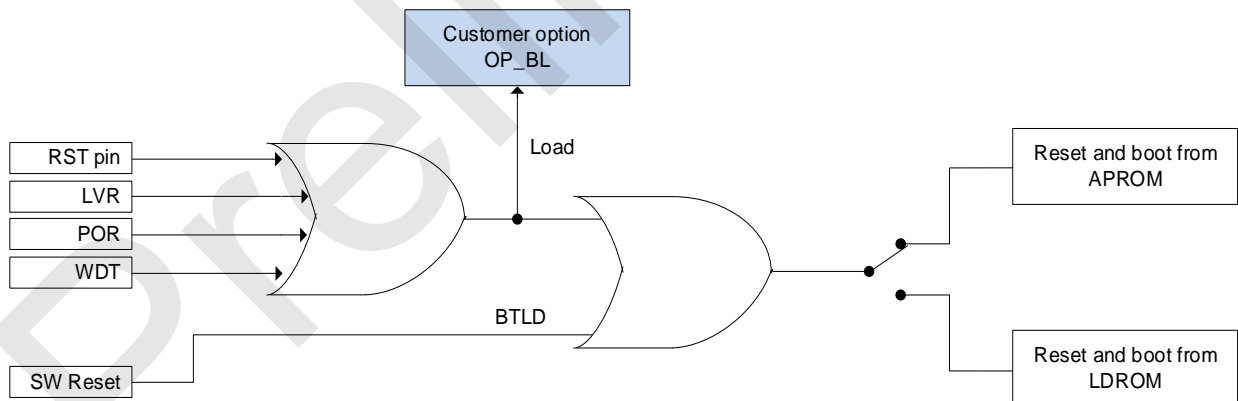

SC95F861XB's boot area switch after reset

7.3.1 External Reset

External reset is a reset pulse signal of a certain width given to SC95F861XB from external RST pin to realize the reset of SC95F861XB. The user can configure the P5.2/RST pin as RST (reset pin) by Code Option.

7.3.2 Low-voltage Reset LVR

The SC95F861XB provides a low-voltage reset circuit. There are 4-level LVR voltage options: 4.3V, 3.7V, 2.9V, 1.9V. The default value is the Option value written by the user. A reset occurs when the VDD voltage is less than the threshold voltage for low-voltage reset and the duration is greater than T_{LVR} . Among them, T_{LVR} is the buffering time of LVR, about 30 μ s.

OP_CTM0(C1H@FFH) Code Option Register 0 (read/write)

Bit number	7	6	5	4	3	2	1	0
Bit Mnemonic	ENWDT	ENXTL	SCLKS[1: 0]		DISRST	DISLVR	LVRs[1: 0]	
R/W	R/W	R/W	R/W		read only	R/W	R/W	
POR	n	n	n		n	n	n	

Bit number	Bit Mnemonic	Description
2	DISLVR	LVR enable setting 0: LVR valid 1: LVR invalid
1~0	LVRs [1: 0]	LVR voltage threshold selection control 11: 4.3V 10: 3.7V 01: 2.9V 00: 1.9V

7.3.3 Power-on Reset (POR)

The SC95F861XB has a power-on reset circuit inside. When the power supply voltage VDD reaches the POR reset voltage, the system automatically resets.

7.3.4 Watchdog Reset (WDT)

The SC95F861XB has a WDT, the clock source of which is the internal 32 kHz LRC. The user can choose whether to enable the watchdog reset function by Code Option.

OP_CTM0 (C1H@FFH) Code Option Register 0 (read/write)

Bit number	7	6	5	4	3	2	1	0
Bit Mnemonic	ENWDT	ENXTL	SCLKS[1: 0]		DISRST	DISLVR	LVRS[1: 0]	
R/W	R/W	R/W	R/W		read only	R/W	R/W	
POR	n	n	n		n	n	n	

Bit number	Bit Mnemonic	Description
7	ENWDT	WDT control bit (This bit is transferred by the system to the value set by the user Code Option) 1: WDT valid 0: WDT invalid

WDTCON (CFH) WDT Control Register (read/write)

Bit number	7	6	5	4	3	2	1	0
Bit Mnemonic	-	-	-	CLRWDT	-	WDTCKS[2: 0]		
R/W	-	-	-	R/W	-	R/W		
POR	x	x	x	0	x	0	0	0

Bit number	Bit Mnemonic	Description
4	CLRWDT	Clear WDT (Only valid when set to 1)

		1: WDT counter restart, cleared by system hardware																		
2~0	WDTCKS [2: 0]	Watchdog clock selection <table border="1"> <thead> <tr> <th>WDTCKS[2: 0]</th> <th>WDT overflow time</th> </tr> </thead> <tbody> <tr> <td>000</td> <td>500ms</td> </tr> <tr> <td>001</td> <td>250ms</td> </tr> <tr> <td>010</td> <td>125ms</td> </tr> <tr> <td>011</td> <td>62.5ms</td> </tr> <tr> <td>100</td> <td>31.5ms</td> </tr> <tr> <td>101</td> <td>15.75ms</td> </tr> <tr> <td>110</td> <td>7.88ms</td> </tr> <tr> <td>111</td> <td>3.94ms</td> </tr> </tbody> </table>	WDTCKS[2: 0]	WDT overflow time	000	500ms	001	250ms	010	125ms	011	62.5ms	100	31.5ms	101	15.75ms	110	7.88ms	111	3.94ms
WDTCKS[2: 0]	WDT overflow time																			
000	500ms																			
001	250ms																			
010	125ms																			
011	62.5ms																			
100	31.5ms																			
101	15.75ms																			
110	7.88ms																			
111	3.94ms																			
7~5,3	-	Reserved																		

7.3.5 Software Reset

PCON (87h) Power Management Control Register (write only, *unreadable*)

Bit number	7	6	5	4	3	2	1	0
Bit Mnemonic	SMOD	-	-	-	RST	-	STOP	IDL
R/W	write only	-	-	-	Write only	-	Write only	Write only

POR	0	x	x	x	n	x	0	0
-----	---	---	---	---	---	---	---	---

Bit number	Bit Mnemonic	Description
3	RST	Software reset control bit: Write status: 0: The program runs normally; 1: The CPU resets immediately after this bit is written to "1"

7.3.6 Register Reset Value

When The SC95F861XB is in reset state, most registers will return to their initial state. The watchdog (WDT) is turned off. The initial value of the program counter PC is 0000h, and the initial value of the stack pointer SP is 07h. The "hot restart" Reset (such as WDT, LVR, software reset, etc.) will not affect the SRAM, and the SRAM value is always the value before the reset. The loss of SRAM content will occur when the power supply voltage is so low that the RAM cannot be saved.

The initial values of the power-on reset of the SFR register see [6.2.1 SFR](#).

7.4 High- frequency System Clock Circuit

The SC95F861XB has a built-in high-precision high-frequency oscillator (HRC) with adjustable oscillation frequency. The HRC is accurately adjusted to 32 MHz@5V/25°C at the factory. Users can set the system clock to 32/16/ 8/4 MHz through the Code Option when programming. This HRC will have a certain drift under the influence of the ambient temperature and operating voltage:

- 2.0V ~ 5.5V,-40 ~ 85°C application environment, frequency error does not exceed ±1%
- -40 ~ 105°C application environment, does not exceed ±2%

The HRC can be automatically calibrated by connecting an external 32.768 kHz crystal oscillator. After calibration, HRC precision can be infinitely close to the precision of external 32.768kHz crystal oscillator.

Users only need to connect an external 32.768 kHz crystal oscillator, and set the external 32.768 kHz crystal oscillator function through the Code Opiton when programming. The HRC self-calibration function is automatically turned on after the IC is powered on.

Note:

1. The clock source of the PWM and TK circuits is fixed at $f_{HRC} = 32 \text{ MHz}$.

2. After the external 32.768kHz crystal oscillator function is enabled, the HRC self-calibration function will start synchronously. At this point, if the external 32.768kHz crystal oscillator is not connected or abnormally connected, the HRC calibration value will have unexpected deviation, resulting in abnormal HRC frequency value.

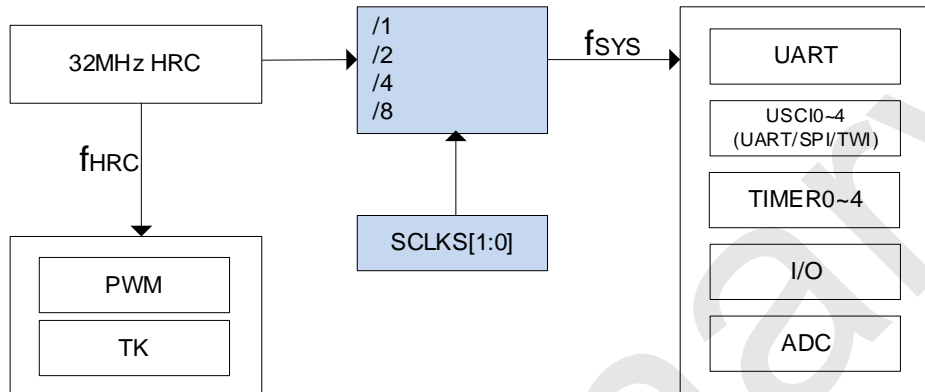

SC95F861XB Internal clock relationship

OP_CTM0 (C1H@FFH) Code Option Register 0 (read/write)

Bit number	7	6	5	4	3	2	1	0
Bit Mnemonic	ENWDT	ENXTL	SCLKS[1: 0]		DISRST	DISLVR	LVRS[1: 0]	
R/W	R/W	R/W	R/W		read only	R/W	R/W	
POR	n	n	n		n	n	n	

Bit number	Bit Mnemonic	Description
5~4	SCLKS[1: 0]	System clock frequency selection bits 00: System clock frequency is HRC frequency divided by 1; 01: System clock frequency is HRC frequency divided by 2;

		10: System clock frequency is HRC frequency divided by 4; 11: System clock frequency is HRC frequency divided by 8;
--	--	--

Note: The SC95F861XB has a special function: the user can modify the value of SFR to adjust the HRC frequency within a certain range. The user can achieve this by configuring the OP_HRCR register. **Note:** HRC can be automatically calibrated by connecting a 32.768 kHz crystal oscillator. Therefore, if the user uses the 32.768 kHz external crystal oscillator function, the HRC frequency will always be corrected to 32 MHz. At this time, adjusting OP_HRCR cannot change the HRC frequency.

OP_HRCR (83h@FFH) System Clock Change Register (read/write)

Bit number	7	6	5	4	3	2	1	0
Bit Mnemonic	OP_HRCR[7: 0]							
R/W	R/W							
POR	n	n	n	n	n	n	n	n

Bit number	Bit Mnemonic	Description
7~0	OP_HRCR[7: 0]	<p>HRC frequency change register</p> <p>The user can change the high-frequency oscillator frequency f_{HRC} by modifying the value of this register, and then change the system clock frequency f_{sys} of the IC:</p> <p>The initial value of OP_HRCR[7: 0] after power-on OP_HRCR[s] is a fixed value to ensure that f_{HRC} is 32 MHz, OP_HRCR[s] of each IC may be different</p> <p>When the initial value is OP_HRCR[s], the system clock frequency f_{sys} of the IC can be set to an accurate 32/16/8/4 MHz through the Option item. When OP_HRCR [7: 0] changes by 1, the f_{sys} frequency changes by about 0.18%</p> <p>The relationship between OP_HRCR [7: 0] and HRC output frequency is as follows:</p>

		OP_HRCR [7: 0] value	fsys actual output frequency (32M as an example)
		OP_HRCR [s]-n	$32000 * (1 - 0.18\% * n)$ kHz
	
		OP_HRCR [s]-2	$32000 * (1 - 0.18\% * 2) = 31\ 884.8$ kHz
		OP_HRCR [s]-1	$32000 * (1 - 0.18\% * 1) = 31\ 942.4$ kHz
		OP_HRCR [s]	32000 kHz
		OP_HRCR [s]+1	$32000 * (1 + 0.18\% * 1) = 32\ 057.6$ kHz
		OP_HRCR [s]+2	$32000 * (1 + 0.18\% * 2) = 32\ 115.2$ kHz
	
		OP_HRCR [s]+n	$32000 * (1 + 0.18\% * n)$ kHz
		<p>Note:</p> <ol style="list-style-type: none"> 1. After each power-on of the IC, the value of OP_HRCR[7: 0] is the value of the HRC closest to 32/16/8/4 MHz; With the help of EEPROM, the user can correct the value of HRC after each power-on to allow HRC of the IC to work at Frequency required by users; 2. In order to ensure the reliable operation of the IC, the maximum operating frequency of the IC should not exceed 10% of 32 MHz, that is 35.2 MHz; 3. Please confirm that the change of HRC frequency will not affect other functions. 	

7.5 Low- frequency RC Oscillator and Low- frequency Clock Timer

The SC95F861XB built-in a 32 kHz RC and 32.768 kHz crystal oscillator circuit, can be used as the Base Timer clock. source.SC95F861XB, which The oscillator is directly connected to a Base Timer, which can wake the CPU from STOP mode and generate an interrupt.

BTMCON (FBH) Low-frequency Timer Control Register (read/write)

Bit number	7	6	5	4	3	2	1	0
Bit Mnemonic	ENBTM	BTMIF	-	-	BTMFS[3: 0]			
R/W	R/W	R/W	-	-	R/W			
POR	0	0	x	x	0	0	0	0

Bit number	Bit Mnemonic	Description
7	ENBTM	Low frequency Base Timer start control 0: Base Timer and its clock source do not start 1: Base Timer and its clock source start
6	BTMIF	Base Timer interrupt application flag When the CPU accepts the Base Timer interrupt, this flag will be automatically cleared by hardware.
3~0	BTMFS [3: 0]	Low frequency clock interrupt frequency selection 0000: An interrupt is generated every 15.625ms 0001: An interrupt is generated every 31.25ms 0010: An interrupt is generated every 62.5ms 0011: An interrupt is generated every 125ms 0100: An interrupt is generated every 0.25 seconds 0101: An interrupt is generated every 0.5 seconds 0110: An interrupt is generated every 1.0 seconds 0111: An interrupt is generated every 2.0 seconds 1000: An interrupt is generated every 4.0ms

		1001: An interrupt is generated every 8.0 seconds 1010: An interrupt is generated every 16.0 seconds 1011: An interrupt is generated every 32.0 seconds 1100~1111: reserved
5~4	-	reserved

OP_CTM0 (C1H@FFH) Code Option Register 0 (read/write)

Bit number	7	6	5	4	3	2	1	0
Bit Mnemonic	ENWDT	ENXTL	SCLKS[1: 0]		DISRST	DISLVR	LVRS[1: 0]	
R/W	R/W	R/W	R/W		R/W	read only	R/W	
POR	n	n	n		n	n	n	

Bit number	Bit Mnemonic	Description
6	ENXTL	External 32.768kHz crystal selector switch 0: The external 32.768kHz crystal is off, P5.0 and P5.1 are valid, and the internal LRC is valid; 1: The external 32.768kHz crystal is turned on, P5.0 and P5.1 are invalid, and the internal LRC is invalid.

Note: HRC can be automatically calibrated by connecting a 32.768 kHz crystal oscillator. Therefore, if the user uses the 32.768 kHz external crystal oscillator function, the HRC frequency will always be corrected to 32 MHz. At this time, adjusting OP_HRCR cannot change the HRC frequency.

The connection circuit used by P5.0/P5.1 external 32.768kHz oscillator as BaseTimer is as follows:

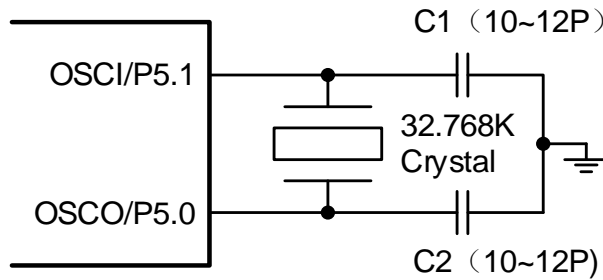

32.768kHz external crystal connection diagram

The internal and external oscillation selection relationship of Base Timer is as follows:

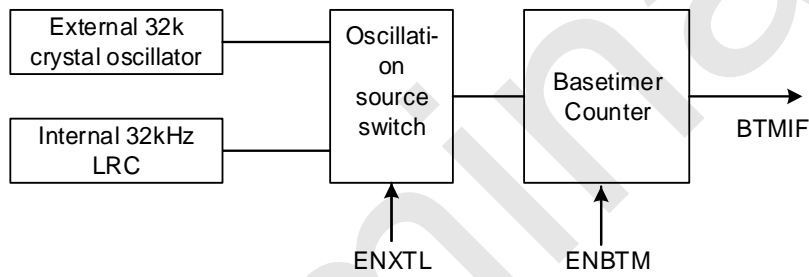

Base Timer Structure diagram

7.6 Power Saving Modes

The SC95F861XB supports two different software selectable power-reducing modes: IDLE and STOP. These modes are accessed through the PCON register.

Setting the PCON.1 bit enters STOP mode. STOP mode stops the internal high-frequency oscillator in order to minimize power consumption. In STOP mode, users can wake up the SC95F861XB through external interrupts INT0~2, Base Timer, TK and CMP interrupt. Also STOP mode can be awakened by an external reset.

Setting the PCON.0 bit enters IDLE mode. In IDLE mode the program stops running and all CPU states are saved before entering IDLE mode. IDLE mode can be woken up by any interrupt.

PCON (87H) Power Management Control Register (read/write) (write only, *not readable*)

Bit number	7	6	5	4	3	2	1	0
Bit Mnemonic	SMOD	-	-	-	RST	-	STOP	IDL

R/W	Write only	-	-	-	Write only	-	Write only	Write only
POR	0	x	x	x	n	x	0	0

Bit number	Bit Mnemonic	Description
1	STOP	STOP mode bit. Setting this bit activates STOP mode operation.
0	IDL	IDLE mode bit. Setting this bit activates IDLE mode operation.

Notes: When Configuring MCU to enter STOP or IDLE mode, the instruction of configuring PCON register should be followed by 8 “NOP” instructions rather than other instructions. Or else, it will be unable to execute following instructions normally after wake-up!

For example: set MCU to enter STOP mode:

Example in C Language

```
#include"intrins.h"
```

```
PCON |= 0x02; // PCON bit1 STOP bit write 1, configure the MCU to enter STOP mode
```

```
_nop_(); // At least 8 _nop_() are required
```

```
_nop_();
```

```
_nop_();
```

```
_nop_();
```

```
_nop_();
```

```
_nop_();
```

```
_nop_();
```

```
_nop_();
```

```
.....
```

Assembly Language:

```
ORL PCON,#02H ; PCON bit1 STOP bit write 1, configure the MCU to enter STOP mode
```

NOP ; At least 8 NOPs are requiredNOP

NOP

NOP

NOP

NOP

NOP

NOP

.....

8 CPU and Instruction Set

8.1 CPU

The SC95F861XB is built around an enhanced super-high-speed 1T 8051 core, and its instructions are fully compatible with classic 8051 core.

8.2 Addressing Mode

The addressing modes of 1T 8051 CPU instructions of the SC95F861XB are: ① Immediate Addressing ② Direct Addressing ③ Indirect Addressing ④ Register Addressing ⑤ Relative Addressing ⑥ Indexed Addressing ⑦ Bit Addressing.

8.2.1 Immediate Addressing

Immediate addressing is also called immediate data addressing. It directly gives the operands participating in the operation in the instruction operand. Examples of instructions are as follows:

MOV A, #50H (This instruction moves the immediate value 50H to accumulator A)

8.2.2 Direct Addressing

In direct addressing mode, the instruction operand field gives the address of the operand to participate in the operation. The direct addressing mode can only be used to represent special function registers, internal data registers, and bit address spaces. The special function registers and bit address spaces can only be accessed by direct addressing.

Examples are as follows:

ANL 50H, #91H

(indicating that the number in the 50H unit is ANDed with the immediate 91H, and the result is stored in the 50H unit. 50H is direct address, representing a unit in the internal data register RAM.)

8.2.3 Indirect Addressing

Indirect addressing is indicated by adding the "@" symbol before R0 or R1. Assuming that the data in R1 is 40H, and the data in the internal data memory 40H unit is 55H, the instruction is

```
MOV A, @R1 (Move data 55H to accumulator A).
```

8.2.4 Register Addressing

When register addressing, operate on the selected operating registers R7~R0, accumulator A, general register B, address register and carry C. Registers R7~R0 are represented by the low three bits of the instruction code, and ACC, B, DPTR and carry bit C are implicitly contained in the instruction code. Therefore, register addressing also includes an implicit addressing method. The selection of the register operating area is determined by RS1 and RS0 in the program status word register PSW. The register specified by the instruction operand refers to the register in the current operating area.

```
INC R0 Refers to(R0)+1→R0
```

8.2.5 Relative Addressing

Relative addressing is to add the current value in the program counter PC to the number given by the second byte of the instruction, and the result is used as the branch address of the branch instruction. The branch address also becomes the branch destination address, the current value in the PC becomes the base address, and the number given by the second byte of the instruction becomes the offset. Since the destination address is relative to the base address in the PC, this addressing method becomes relative addressing. The offset is a signed number, and the range that can be expressed is -128~+127. This addressing method is mainly used for branch instructions.

```
JC $ +50H
```

It means that if the carry bit C is 0, the content in the program counter PC does not change, that is, it does not transfer. If the carry bit C is 1, the current value as base address in the PC plus the offset 50H will be used as the destination address of the branch instruction.

8.2.6 Indexed Addressing

In the indexed addressing mode, the instruction operand specifies an index register that stores the index base address. In indexed addressing, the offset is added to the index base value, and the result is used as the address of the operand. The index registers are the program counter PC and the address register DPTR.

```
MOVC A, @A+DPTR
```

It indicates that the accumulator A is an offset register, and its content is added to the content of the address register DPTR. The result is used as the address of the operand, and the number in this unit is taken out and sent to the accumulator A.

8.2.7 Bits Addressing

Bit addressing refers to the addressing mode when performing bit operations on some internal data memory RAMs and special function registers that can perform bit operations. When performing bit operations, with the help of carry bit C as a bit operation accumulator, the instruction operand directly gives the address of the bit, and then performs bit operation on the bit according to the nature of the opcode. The bit address is exactly the same as the byte address encoding method in direct byte addressing, which is mainly distinguished by the nature of the operation instruction, and special attention should be paid when using it.

```
MOV C, 20H (The value of the bit manipulation register with address 20H is sent to carry bit C)
```

Preliminary

9 Interrupts

SC95F861XB provides 20 interrupt sources: TIMER 0~4, INT0~2, ADC, PWM, UART, USCIO~5, BASE TIMER, TK, CMP. The 20 interrupt sources are divided into two interrupt priorities and can be set to either high or low priority separately. Three external interrupts can be set as up, down or both trigger conditions for each interrupt source respectively. Each interrupt has its own priority setting bit, interrupt flag, interrupt vector and enable bit respectively. The total enable bit EA can open or close all interrupts.

9.1 Interrupt Source and Vector

The list of the SC95F861XB interrupt sources, interrupt vectors, and related control bits are as follows:

Interrupt Source	Interrupt condition	Interrupt Flag	Interrupt Enable Control	Interrupt Priority Control	Interrupt Vector	Query Priority	Interrupt Number (C51)	Flag Clear Mode	Capability of Waking up STOP
INT0	External interrupt 0 conditions are met	IE0	EINT0	IPINT0	0003H	1 (HIGH)	0	H/W Auto	YES
Timer 0	Timer 0 overflow	TF0	ET0	IPT0	000BH	2	1	H/W Auto	NO
INT1	External interrupt 1 conditions are met	IE1	EINT1	IPINT1	0013H	3	2	H/W Auto	YES
Timer 1	Timer 1 overflow	TF1	ET1	IPT1	001BH	4	3	H/W Auto	NO
UART	Receive or send completed	RI/TI	EUART	IPUART	0023H	5	4	Must user Clear	NO
Timer 2	Timer 2 overflow	TFX	ET2	IPT2	002BH	6	5	Must user Clear	NO
ADC	ADC conversion completed	ADCIF	EADC	IPADC	0033H	7	6	Must user Clear	NO

USCI0	Receive or send completed	SPIF0/TWIF0	EUSCI0	IPSPI	003BH	8	7	Must user Clear	NO
PWM	PWM overflow	PWMIF	EPWM	IPPWM	0043H	9	8	Must user Clear	NO
BTM	Base timer overflow	BTMIF	EBTM	IPBTM	004BH	10	9	H/W Auto	YES
INT2	External interrupt 2 conditions are met	-	EINT2	IPINT2	0053H	11	10	-	YES
TK	Touch Key counter overflowed	TKIF	ETK	IPTK	005BH	12	11	H/W Auto	NO
CMP	Comparator interrupt condition met	CMPIF	ECMP	IPCMP	0063H	13	12	Must user Clear	YES
Timer 3	Timer 3 overflow	TFX	ET3	IPT3	006BH	14	13	Must user Clear	NO
Timer 4	Timer 4 overflow	TFX	ET4	IPT4	0073H	15	14	Must user Clear	NO
USCI1	Receive or send completed	SPIF1/TWIF1	EUSCI1	IPSPI1	007BH	16	15	Must user Clear	NO
USCI2	Receive or send completed	SPIF2/TWIF2	EUSCI2	IPSPI2	0083H	17	16	Must user Clear	NO
USCI3	Receive or send completed	SPIF3/TWIF3	EUSCI3	IPSPI3	008BH	18	17	Must user Clear	NO

USCI4	Receive or send completed	SPIF4/TWIF4	EUSCI4	IPSPI4	0093H	19	18	Must user Clear	NO
USCI5	Receive or send completed	SPIF5/TWIF5	EUSCI5	IPSPI5	009BH	20	19	Must user Clear	NO

Under the circumstance where the master interrupt control bit EA and the respective interrupt control bit have been enable, the interrupt occurrence is shown below:

Timer Interrupt: Interrupt generates when Timer 0 or Timer 1 overflows and the interrupt flag TF0 or TF1 is set to “1”. When the microcontroller unit responds to the timer interrupt, the interrupt flag TF0 or TF1 is reset automatically by hardware. Interrupt generates when Timer 2 overflows and the interrupt flag TF2 is set to “1”. Once Timer 2 interrupt generates, the hardware would not automatically clear TF2 bit, which must be cleared by the user’s software.

UART Interrupt: When UART0 completes receiving or transmitting a frame of data, bit RI or TI will be set to “1” automatically by hardware, and UART interrupt occurs. Once UART interrupt occurs, the hardware would not automatically clear up RI/TI bit, which shall be cleared by user’s software.

ADC Interrupt: After ADC conversion is completed, ADC interrupt generates, whose interrupt flag is the ADC conversion completion flag EOC/ADCIF (ADCCON.5). When user starts ADCS conversion, EOC will be reset automatically by hardware. Once conversion completes, EOC would be set to “1” automatically by hardware. User should clear the ADC interrupt flag by software when the interrupt service routine is executed after ADC interrupt generates.

SSI Interrupt: When SSI completes receiving or transmitting a frame of data, SPIF/TWIF bit will be set to “1” automatically by hardware, and SSI interrupt generates. When the microcontroller unit serves SSI interrupt, the interrupt flag SPIF/TWIF must be cleared by software.

PWM Interrupt: When PWM counter overflows (beyond PWMPD), the flag will be set as 1 automatically by hardware. Meanwhile, if the PWM interrupt control bit IE1[1] (EPWM) is set as 1, PWM interrupt will occurs. Once PWM interrupt occurs, the hardware would not clear the interrupt flag automatically, which shall be cleared by user’s software.

External Interrupt INT0 ~ 2: When any external interrupt pin meets the interrupt conditions, external interrupt generates. The external interrupt INT0 and INT1 would set up interrupt flag IE0 and IE1 respectively, which will be automatically cleared by hardware rather than user. User can set the priority level of each interrupt through IP register. Besides, external interrupt INT0 ~ 2 can also wake up STOP mode of microcontroller unit.

9.2 Interrupt Structure Diagram

The interrupt structure of SC95F861XB is shown below:

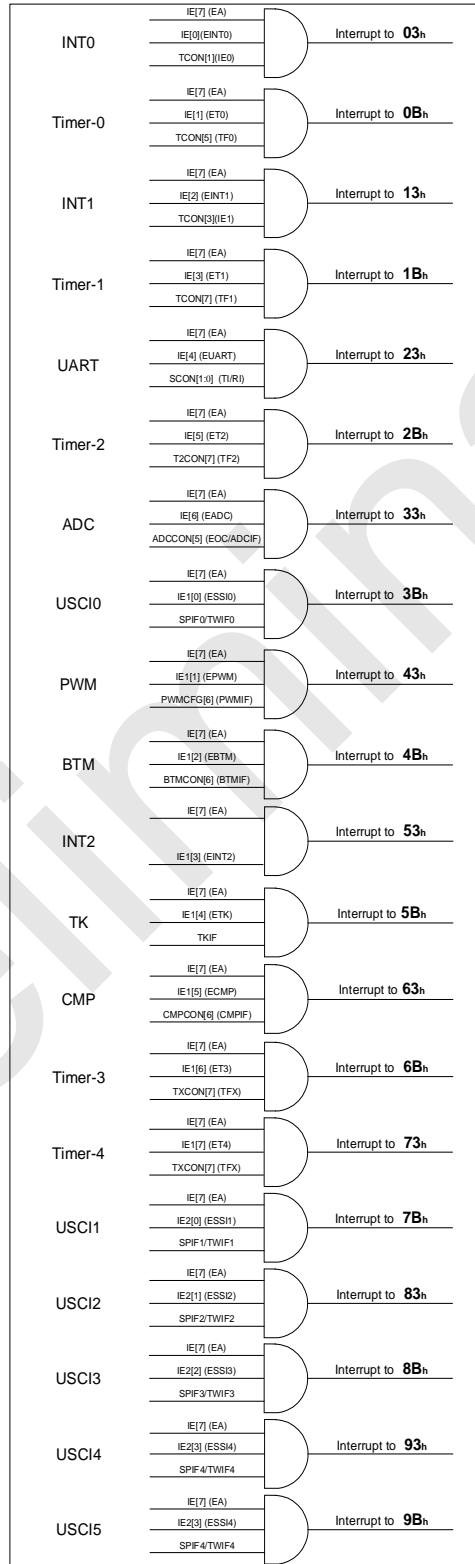

SC95F861XB Interrupt structure and vector

9.3 Interrupt Priority

Each interrupt source can be individually programmed to one of two priority levels by setting or clearing bits in the interrupt priority registers: IP, IP0, IP1. An interrupt service routine in progress can be interrupted by a higher priority interrupt. The highest priority interrupt cannot be interrupted by any other interrupt source. If two requests of different priority levels are pending at the end of an instruction, the request of higher priority level is serviced. If requests of the same priority level are pending at the end of an instruction, an internal polling sequence determines which request is serviced. The polling sequence is based on the vector address; an interrupt with a lower vector address has higher priority than an interrupt with a higher vector address.

9.4 Interrupt Processing Flow

When an interrupt is generated and responded by the CPU, the main program execution is interrupted and the following operations will be performed:

- ① The currently executing instruction is finished;
- ② The PC value is pushed into the stack to protect the scene;
- ③ The interrupt vector address is loaded into the program counter PC;
- ④ Execute the corresponding interrupt service program;
- ⑤ The interrupt service routine ends and RETI;
- ⑥ Unstack the PC value and return to the program before the interruption.

In this process, the system will not immediately execute other interrupts of the same priority, but will retain the interrupt request that has occurred, and after the current interrupt processing is completed, go to execute a new interrupt request.

9.5 Interrupt-related SFR Registers

IE (A8H) Interrupt Enable Register (read/write)

Bit number	7	6	5	4	3	2	1	0
Bit Mnemonic	EA	EADC	ET2	EUART	ET1	EINT1	ET0	EINT0
R/W	R/W	R/W	R/W	R/W	R/W	R/W	R/W	R/W
POR	0	0	0	0	0	0	0	0

Bit number	Bit Mnemonic	Description
------------	--------------	-------------

7	EA	Interrupt enable total control 0: Close all interrupts 1: Enable all interrupts
6	EADC	ADC interrupt enable control 0: Disable ADC interrupt 1: Allow the ADC to generate an interrupt when the conversion is complete
5	ET2	Timer 2 interrupt enable control 0: Disable Timer 2 interrupt 1: Enable Timer 2 interrupt
4	EUART	UART interrupt enable control 0: Disable UART interrupt 1: Allow UART interrupt
3	ET1	Timer 1 interrupt enable control 0: Disable Timer 1 interrupt1: Enable Timer 1 interrupt
2	EINT1	External interrupt 1 enable control 0: close INT1 interrupt 1: Enable INT1 interrupt
1	ET0	Timer 0 interrupt enable control 0: Disable TIMERO interrupt 1: Enable TIMERO interrupt
0	EINT0	External interrupt 0 enable control 0: close INTO interrupt

		1: Enable INT0 interrupt
--	--	--------------------------

IP (B8H) Interrupt Priority Control Register (Read/Write)

Bit number	7	6	5	4	3	2	1	0
Bit Mnemonic	-	IPADC	IPT2	IPUART	IPT1	IPINT1	IPT0	IPINT0
R/W	-	R/W	R/W	R/W	R/W	R/W	R/W	R/W
POR	x	0	0	0	0	0	0	0

Bit number	Bit Mnemonic	Description
6	IPADC	ADC interrupt priority selection 0: ADC interrupt priority is low 1: ADC interrupt priority is high
5	IPT2	Timer 2 interrupt priority selection 0: Timer 2 interrupt priority is low 1: Timer 2 interrupt priority is high
4	IPUART	UART interrupt priority selection 0: UART interrupt priority is low 1: UART interrupt priority is high
3	IPT1	Timer 1 interrupt priority selection 0: Timer 1 interrupt priority is low 1: Timer 1 interrupt priority is high

2	IPINT1	INT1 counter interrupt priority selection 0: INT1 interrupt priority is low 1: INT1 interrupt priority is high
1	IPT0	Timer 0 interrupt priority selection 0: Timer 0 interrupt priority is low 1: Timer 0 interrupt priority is high
0	IPINT0	INT0 counter interrupt priority selection 0: INT0 interrupt priority is low 1: INT0 interrupt priority is high
7	-	Reserved

IE1 (A9H) Interrupt Enable Register 1 (read/write)

Bit number	7	6	5	4	3	2	1	0
Bit Mnemonic	ET4	ET3	ECMP	ETK	EINT2	EBTM	EPWM	EUSCIO
R/W	R/W	R/W	R/W	R/W	R/W	R/W	R/W	R/W
POR	0	0	0	0	0	0	0	0

Bit number	Bit Mnemonic	Description
7	ET4	Timer 4 interrupt enable control 0: Disable Timer 4 interrupt 1: Enable Timer 4 interrupt

6	ET3	Timer 3 interrupt enable control 0: Disable Timer 3 interrupt 1: Enable Timer 3 interrupt
5	ECMP	Analog comparator interrupt enable control 0: Disable the analog comparator interrupt 1: Open the analog comparator interrupt
4	TK	Touch Key interrupts enable control 0: Turn off Touch Key interrupt 1: Open Touch Key interrupt
3	EINT2	External interrupt 2 enable control 0: close INT2 interrupt 1: Open INT2 interrupt
2	EBTM	Base Timer interrupt enable control 0: Disable Base Timer interrupt 1: Enable Base Timer interrupt
1	EPWM	PWM interrupt enable control 0: Disable PWM interrupt 1: Enable interrupt when PWM count overflows
0	EUSCIO	Three-in-one serial port USCIO interrupt enable control 0: Disable serial port interrupt 1: Allow serial port interrupt

IP1 (B9H) Interrupt Priority Control Register 1 (read/write)

Bit number	7	6	5	4	3	2	1	0
Bit Mnemonic	IPT4	IPT3	IPCMP	IPTK	IPINT2	IPBTM	IPPWM	IPUSCIO
R/W	R/W	R/W	R/W	R/W	R/W	R/W	R/W	R/W
POR	0	0	0	0	0	0	0	0

Bit number	Bit Mnemonic	Description
7	IPT4	Timer 4 interrupt priority selection 0: Timer 4 interrupt priority is low 1: Timer 4 interrupt priority is high
6	IPT3	Timer 3 interrupt priority selection 0: Timer 3 interrupt priority is low 1: Timer 3 interrupt priority is high
5	IPCMP	Analog comparator interrupt priority selection 0: Analog comparator interrupt priority is low 1: Analog comparator interrupt priority is high
4	IPTK	Touch Key interrupts priority selection 0: Touch Key interrupt priority is low 1: Touch Key interrupt priority is high
3	IPINT2	INT2 counter interrupt priority selection 0: INT2 interrupt priority is low 1: INT2 interrupt priority is high

2	IPBTM	Base Timer interrupt priority selection 0: Base Timer interrupt priority is low 1: Base Timer interrupt priority is high
1	IPPWM	PWM interrupt enable selection 0: PWM interrupt priority is low 1: PWM interrupt priority is high
0	IPUSCIO	Three-in-one serial port USCIO interrupt priority selection 0: USCIO interrupt priority is low 1: USCIO interrupt priority is high

IE2 (AAH) Interrupt Enable Register 2 (read/write)

Bit number	7	6	5	4	3	2	1	0
Symbol	-	-	-	EUSCI5	EUSCI4	EUSCI3	EUSCI2	EUSCI1
Read/ Write	-	-	-	Read/ Write	Read/ Write	Read/ Write	Read/ Write	Read/ Write
Initial power-on value	x	x	x	0	0	0	0	0

Bit number	Bit Mnemonic	Description
4	EUSCI5	Three-in-one serial port USCIO5 interrupt enable control 0: Disable serial port interrupt 1: Allow serial port interrupt

3	EUSCI4	Three-in-one serial port USCI4 interrupt enable control 0: Disable serial port interrupt 1: Allow serial port interrupt
2	EUSCI3	Three-in-one serial port USCI3 interrupt enable control 0: Disable serial port interrupt 1: Allow serial port interrupt
1	EUSCI2	Three-in-one serial port USCI2 interrupt enable control 0: Disable serial port interrupt 1: Allow serial port interrupt
0	EUSCI1	Three-in-one serial port USCI1 interrupt enable control 0: Disable serial port interrupt 1: Allow serial port interrupt
7~2	-	Reserved

IP2 (BAH) Interrupt Priority Control Register 2 (read/write)

Bit number	7	6	5	4	3	2	1	0
Bit Mnemonic	-	-	-	IPUSCI5	IPUSCI4	IPUSCI3	IPUSCI 2	IPUSCI1
R/W	-	-	-	R/W	R/W	R/W	R/W	R/W
POR	x	x	x	0	0	0	0	0

Bit number	Bit Mnemonic	Description
------------	--------------	-------------

	IPUSCI5	Three-in-one serial port USCI5 interrupt priority selection 0: USCI5 interrupt priority is low 1: USCI5 interrupt priority is high
	IPUSCI4	Three-in-one serial port USCI4 interrupt priority selection 0: USCI4 interrupt priority is low 1: USCI4 interrupt priority is high
	IPUSCI3	Three-in-one serial port USCI3 interrupt priority selection 0: USCI3 interrupt priority is low 1: USCI3 interrupt priority is high
1	IPUSCI2	Three-in-one serial port USCI2 interrupt priority selection 0: USCI2 interrupt priority is low 1: USCI2 interrupt priority is high
0	IPUSCI1	Three-in-one serial port USCI1 interrupt priority selection 0: USCI1 interrupt priority is low 1: USCI1 interrupt priority is high
7~5	-	Reserved

TCON (88H) Timer Control Register (read/write)

Bit number	7	6	5	4	3	2	1	0
Bit Mnemonic	TF1	TR1	TF0	TR0	IE1	-	IE0	-
R/W	R/W	R/W	R/W	R/W	R/W	-	R/W	-
POR	0	0	0	0	0	x	0	x

Bit number	Bit Mnemonic	Description
3	IE1	INT1 overflow interrupt request flag. INT1 generates an overflow. When an interrupt occurs, the hardware sets IE1 to "1" and applies for an interrupt. When the CPU responds, the hardware clears "0".
1	IE0	INT0 overflow interrupt request flag. INT0 generates an overflow. When an interrupt occurs, the hardware sets IE0 to "1" and applies for an interrupt. When the CPU responds, the hardware clears "0".
2,0	-	Reserved

INT0F (B4H) INT0 Falling Edge Interrupt Control Register (read/write)

Bit number	7	6	5	4	3	2	1	0
Bit Mnemonic	INT0F7	INT0F6	INT0F5	INT0F4	-	-	-	-
R/W	R/W	R/W	R/W	R/W	-	-	-	-
POR	0	0	0	0	x	x	x	x

Bit number	Bit Mnemonic	Description
7~4	INT0Fn (n=7~4)	INT0 falling edge interrupt control 0: INT0n falling edge interrupt close 1: INT0n falling edge interrupt enable
3~0	-	Reserved

INT0R (BBH) INT0 Rising Edge Interrupt Control Register (read/write)

Bit number	7	6	5	4	3	2	1	0
Bit Mnemonic	INT0R7	INT0R6	INT0R5	INT0R4	-	-	-	-
R/W	R/W	R/W	R/W	R/W	-	-	-	-
POR	0	0	0	0	x	x	x	x

Bit number	Bit Mnemonic	Description
7~4	INT0Rn (n=7~4)	INT0 rising edge interrupt control 0: INT0n rising edge interrupt close 1: INT0n rising edge interrupt enable
3~0	-	Reserved

INT1F (BCH) INT1 Falling Edge Interrupt Control Register (read/write)

Bit number	7	6	5	4	3	2	1	0
Bit Mnemonic	INT1F7	INT1F6	INT1F5	INT1F4	INT1F3	INT1F2	INT1F1	INT1F0
R/W	R/W	R/W	R/W	R/W	R/W	R/W	R/W	R/W
POR	0	0	0	0	0	0	0	0

Bit number	Bit Mnemonic	Description
7~0	INT1Fn (n=7~0)	INT1 falling edge interrupt control 0: INT1n falling edge interrupt close

		1: INT1n falling edge interrupt enable
--	--	--

INT1R (BDH) INT1 Rising Edge Interrupt Control Register (read/write)

Bit number	7	6	5	4	3	2	1	0
Bit Mnemonic	INT1R7	INT1R6	INT1R5	INT1R4	INT1R3	INT1R2	INT1R1	INT1R0
R/W	R/W	R/W	R/W	R/W	R/W	R/W	R/W	R/W
POR	0	0	0	0	0	0	0	0

Bit number	Bit Mnemonic	Description
7~0	INT1Rn (n=7~0)	INT1 rising edge interrupt control 0: INT1n rising edge interrupt off 1: INT1n rising edge interrupt enable

INT2F (BEH) INT2 Falling Edge Interrupt Control Register (read/write)

Bit number	7	6	5	4	3	2	1	0
Bit Mnemonic	-	-	-	-	INT2F3	INT2F2	INT2F1	INT2F0
R/W	-	-	-	-	R/W	R/W	R/W	R/W
POR	x	x	x	x	0	0	0	0

Bit number	Bit Mnemonic	Description
3~0	INT2Fn (n=3~0)	INT2 falling edge interrupt control 0: INT2n falling edge interrupt close 1: INT2n falling edge interrupt enable
7~4	-	Reserved

INT2R (BFH) INT2 Rising Edge Interrupt Control Register (read/write)

Bit number	7	6	5	4	3	2	1	0
Bit Mnemonic	-	-	-	-	INT2R3	INT2R2	INT2R1	INT2R0
R/W	-	-	-	-	R/W	R/W	R/W	R/W
POR	x	x	x	x	0	0	0	0

Bit number	Bit Mnemonic	Description
3~0	INT2Rn (n=3~0)	INT2 rising edge interrupt control 0: INT2n rising edge interrupt close 1: INT2n rising edge interrupt enable
7~4	-	Reserved

10 Timer/Counter T0 and T1

Timer 0 and Timer 1 inside the SC95F861XB MCU are two 16-bit timers/counters. They have two operating modes: counting mode and timing mode. There is a control bit C/Tx in the special function register TMOD to select whether T0 and T1 are timers or counters. They are essentially an addition counter, but the source of the count is different. The source of the timer is the system clock or its divided clock, but the source of the counter is the input pulse of the external pin. Only when TRx=1, T0 and T1 will be opened to count.

In counter mode, for each pulse on the P0.2/T0 and P0.3/T1 pins, the count value of T0 and T1 increases by 1, respectively.

In the timer mode, the count source of T0 and T1 can be selected as fsys/12 or fsys through the special function register TMCON (fsys is the divided system clock).

There are 4 operating modes for timer/counter T0, and 3 operating modes for timer/counter T1 (mode 3 does not exist):

- ① Mode 0: 13-bit timer/counter mode
- ② Mode 1: 16-bit timer/counter mode
- ③ Mode 2: 8-bit auto-reload mode
- ④ Mode 3: Two 8-bit timer/counter modes

In the above modes, modes 0, 1, and 2 of T0 and T1 are the same, and mode 3 is different.

10.1 T0 and T1-related Registers

Symbol	Address	Description	7	6	5	4	3	2	1	0	POR
TCON	88H	Timer control register	TF1	TR1	TF0	TR0	IE1	-	IE0	-	00000x0xb
TMOD	89H	Timer operating mode register	-	C/T1	M11	M01	-	C/T0	M10	M00	x000x000b
TL0	8AH	Low 8 bits of timer 0	TL0[7: 0]								00000000b
TL1	8BH	Low 8 bits of timer 1	TL1[7: 0]								00000000b
TH0	8CH	Timer 0 high 8 bits	TH0[7: 0]								00000000b
TH1	8DH	Timer 1 high 8 bits	TH1[7: 0]								00000000b
TMCON	8EH	Timer frequency control register	USMDX[1 : 0]	-	-	-	-	-	T1FD	T0FD	00xxxx00b

The explanation of each register is as follows:

TCON (88H) Timer Control Register (read/write)

Bit number	7	6	5	4	3	2	1	0
Bit Mnemonic	TF1	TR1	TF0	TR0	IE1	-	IE0	-
R/W	R/W	R/W	R/W	R/W	R/W	-	R/W	-
POR	0	0	0	0	0	x	0	x

Bit number	Bit Mnemonic	Description
7	TF1	T1 overflow interrupt request flag. T1 generates an overflow. When an interrupt occurs, the hardware sets TF1 to "1" and applies for an interrupt. When the CPU responds, the hardware clears "0".
6	TR1	Operation control bit of timer T1. This bit is set and cleared by software. When TR1=1, T1 is allowed to start counting. When TR1=0, T1 counting is prohibited.
5	TF0	T0 overflow interrupt request flag. T0 overflows. When an interrupt occurs, the hardware sets TF0 to "1" and applies for an interrupt. When the CPU responds, the hardware clears "0".
4	TR0	Operation control bit of timer T0. This bit is set and cleared by software. When TR0=1, T0 is allowed to start counting. When TR0=0, T0 counting is prohibited.
2,0	-	Reserved

TMOD (89H) Timer Operating Mode Register (read/write)

Bit number	7	6	5	4	3	2	1	0
------------	---	---	---	---	---	---	---	---

Bit Mnemonic	-	C/T1	M11	M01	-	C/T0	M10	M00
R/W	-	R/W	R/W	R/W	-	R/W	R/W	R/W
POR	x	0	0	0	x	0	0	0
	T1				T0			

Bit number	Bit Mnemonic	Description
6	C/T1	TMOD[6] control timer 1 0: Timer, T1 count comes from fsys frequency division 1: Counter, T1 count comes from external pin T1/P0.3
5~4	M11,M01	Timer/Counter 1 mode selection 00: 13-bit timer/counter, the upper 3 bits of TL1 are invalid 01: 16-bit timer/counter, TL1 and TH1 all are valid 10: 8-bit auto-reload timer, automatically reload the value stored in TH1 into TL1 when overflow 11: Timer/Counter 1 is invalid (stop counting)
2	C/T0	TMOD[2] control timer 0 0: Timer, T0 count comes from fsys frequency division 1: Counter, T0 count comes from external pin T0/P0.2
1~0	M10,M00	Timer/Counter 0 mode selection 00: 13-bit timer/counter, the upper 3 bits of TL0 are invalid 01: 16-bit timer/counter, TL0 and TH0 all are valid 10: 8-bit auto-reload timer, automatically reload the value stored in TH0 into TL0 when overflow

		11: Timer 0 is now a dual 8-bit timer/counter. TL0 is an 8-bit timer/counter controlled by the control bits of standard timer 0; TH0 is only an 8-bit timer controlled by the control bits of timer 1.
7,3	-	Reserved

TMOD[0]~TMOD[2] in TMOD register is to set the operating mode of T0; TMOD[4]~TMOD[6] is to set the operating mode of T1.

The timer and counter Tx functions are selected by the control bits C/Tx of the special function register TMOD. M0x and M1x are used to select the Tx operating mode. TRx acts as the switch control of T0 and T1. Only when TRx=1, T0 and T1 are turned on.

TMCON (8EH) Timer Frequency Control Register (read/write)

Bit number	7	6	5	4	3	2	1	0
Bit Mnemonic	USMDX[1: 0]		-	-	-	-	T1FD	T0FD
R/W	R/W	R/W	-	-	-	-	R/W	R/W
POR	0	0	x	x	x	x	0	0

Bit number	Bit Mnemonic	Description
1	T1FD	T1 input frequency selection control 0: T1 frequency is derived from fsys/12 1: T1 frequency is derived from fsys
0	T0FD	T0 input frequency selection control 0: T0 frequency is derived from fsys/12 1: T0 frequency is derived from fsys

IE (A8H) Interrupt Enable Register (read/write)

Bit number	7	6	5	4	3	2	1	0
Bit Mnemonic	EA	EADC	ET2	EUART	ET1	EINT1	ET0	EINT0
R/W	R/W	R/W	R/W	R/W	R/W	R/W	R/W	R/W
POR	0	0	0	0	0	0	0	0

Bit number	Bit Mnemonic	Description
3	ET1	Timer 1 interrupt enable control 0: Disable Timer 1 interrupt 1: Enable Timer 1 interrupt
1	ET0	Timer 0 interrupt enable control 0: Disable Timer 0 interrupt 1: Enable Timer 0 interrupt

IP (B8H) Interrupt Priority Control Register (Read/Write)

Bit number	7	6	5	4	3	2	1	0
Bit Mnemonic	-	IPADC	IPT2	IPUART	IPT1	IPINT1	IPT0	IPINT0
R/W	-	R/W	R/W	R/W	R/W	R/W	R/W	R/W
POR	x	0	0	0	0	0	0	0

Bit number	Bit Mnemonic	Description
------------	--------------	-------------

3	IPT1	Timer 1 interrupt priority 0: Set the interrupt priority of Timer 1 to "Low" 1: Set the interrupt priority of Timer 1 to "High"
1	IPT0	Timer 0 interrupt priority 0: Set the interrupt priority of Timer 0 to "Low" 1: Set the interrupt priority of Timer 0 to "High"

10.2 T0 Operating Modes

By setting M10 and M00 (TMOD[1], TMOD[0]) in the register TMOD, timer/counter 0 can realize 4 different operating modes.

Operating Mode 0: 13-bit Counter/Timer

TH0 register stores the upper 8 bits (TH0.7~TH0.0) of the 13-bit counter/timer, and the TL0 stores the low 5 bits (TL0.4~TL0.0). The upper three bits of TL0 (TL0.7~TL0.5) are uncertain values and should be ignored when reading. When the 13-bit timer/counter overflows, the system will set the timer overflow flag TF0 to 1. If the timer 0 interrupt is enabled, an interrupt will be generated.

C/T0 bit selects the clock input source of the counter/timer. If C/T0=1, the level change of the timer 0 input pin T0 (P0.2) from high to low will increase the timer 0 data register by 1. If C/T0=0, select the frequency division of the system clock as the clock source of timer 0.

When TR0 is set to 1, the timer T0 is started. Setting TR0 does not forcibly reset the timer, meaning that if TR0 is set, the timer register will start counting from the value when TR0 was cleared last time. Therefore, before enabling the timer, the initial value of the timer register should be set.

When applied as a timer, TOFD can be configured to select the frequency division ratio of the clock source.

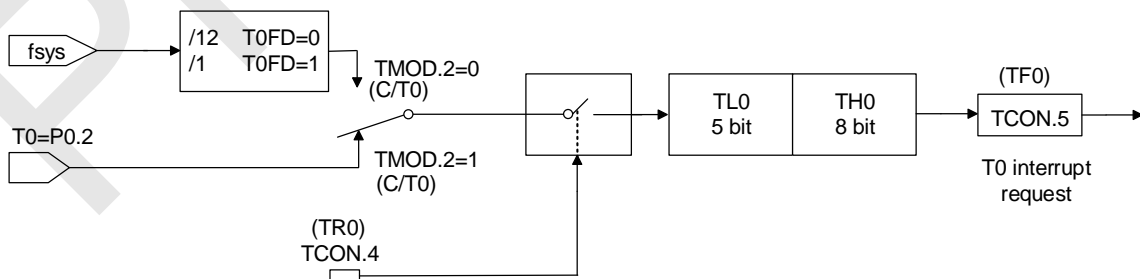

Timer/counter operating mode 0: 13-bit timer/counter

Operating Mode 1: 16-bit Counter/Timer

Except for using a 16-bit (all 8-bit data of TL0 is valid) counters/timers, Mode 1 and Mode 0 operate in the same way. The way to open and configure the counter/timer is the same.

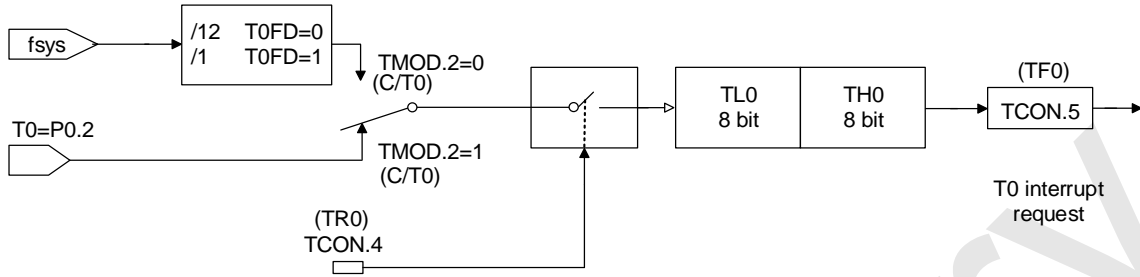

Timer/Counter Operating Mode 1: 16-bit Timer/Counter

Operating Mode 2: 8-bit Automatic Reload Counter/Timer

In operating mode 2, Timer 0 is an 8-bit auto-reload counter/timer. TL0 stores the count value, and TH0 stores the reload value. When the counter in TL0 overflows to 0x00, the timer overflow flag TF0 is set to 1, and the value of register TH0 is reloaded into register TL0. If the timer interrupt is enabled, an interrupt will be generated when TF0 is set to 1, but the reload value in TH0 will not change. Before allowing the timer to count correctly, TL0 must be initialized to the required value.

Except for the auto-reload function, the counter/timer in operating mode 2 is enabled and configured in the same way as in modes 0 and 1.

When used as a timer, the register TMCON.0 (T0FD) can be configured to select the ratio of the timer clock source divided by the system clock fsys.

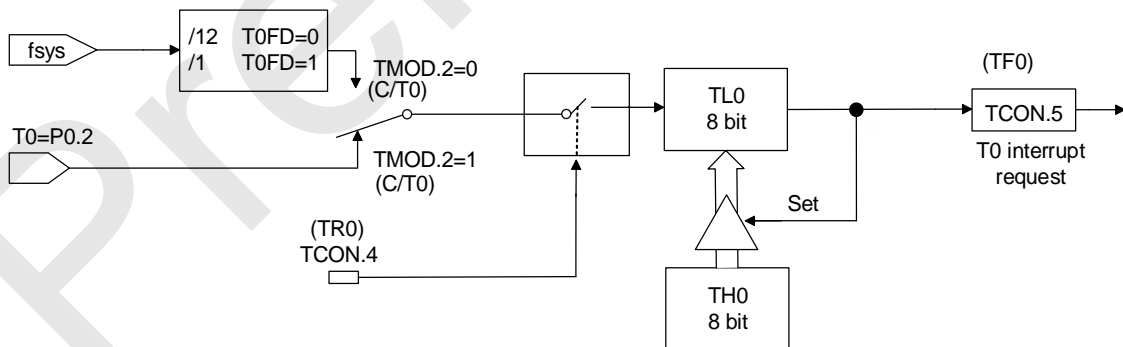

Timer/counter operating mode 2: 8-bit timer/counter with automatic reload

Operating Mode 3: Two 8-bit Counters/Timers (Timer 0 Only)

In operating mode 3, Timer 0 is used as two independent 8-bit counters/timers, which are controlled by TL0 and TH0, respectively. TL0 is controlled by timer 0 control bits (in TCON) and status bits (in TMOD): TR0, C/T0, TF0. Timer 0 can select the timer mode or counter mode through T0 TMOD.2 (C/T0).

TH0 sets related control by timer 1 control TCON, but TH0 is only limited to timer mode and cannot be set to counter mode by TMOD.2 (C/T0). TH0 is enabled by the control of the timer control bit TR1, and TR1=1 needs to be set. When an overflow occurs and an interrupt is generated, TF1 will be set to 1, and the interrupt will be processed according to T1.

When T0 is set to operating mode 3, the TH0 timer occupies the interrupt resources of T1 and the registers in TCON, and the 16-bit counter of T1 will stop counting, which is equivalent to "TR1=0". When using the TH0 timer to work, set TR1=1.

10.3 T1 Operating Mode

By setting M11 and M01 (TMOD[5], TMOD[4]) in the register TMOD, timer/counter 1 can realize three different operating modes.

Operating mode 0: 13-bit Timer/Counter

The TH1 register stores the upper 8 bits (TH1.7~TH1.0) of the 13-bit counter/timer; the TL1 stores the low 5 bits (TL1.4~TL1.0). The upper three bits of TL1 (TL1.7~TL1.5) are uncertain values and should be ignored when reading. When the 13-bit timer counter increments and overflows, the system sets the timer overflow flag TF1 to 1. If Timer 1 interrupt is enabled, an interrupt will be generated. The C/T1 bit selects the clock source of the counter/timer.

If C/T1=1, the level of timer 1 input pin T1 (P0.3) changes from high to low, which will increase the timer 1 data register by 1. If C/T1=0, select the frequency division of the system clock as the clock source of timer 1.

Set TR1 to enable the timer. Setting TR1 does not forcibly reset the timer, meaning that if TR1 is set to 1, the timer register will start counting from the value when TR1 was cleared to 0 last time. Therefore, before enabling the timer, the initial value of the timer register should be set.

When applied as a timer, T1FD can be configured to select the frequency division ratio of the clock source.

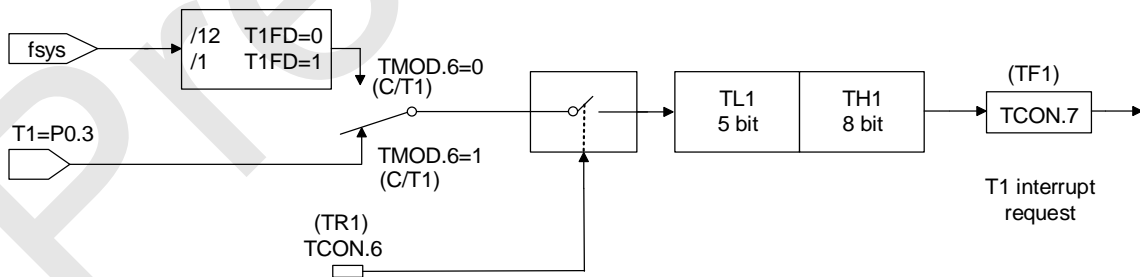

Timer/counter operating mode 0: 13-bit timer/counter

Operating mode 1: 16-bit Counter/Timer

Except for using a 16-bit (all 8-bit data of TL1 is valid) counter/timer, Mode 1 and Mode 0 operate in the same way. The way to open and configure the counter/timer is the same.

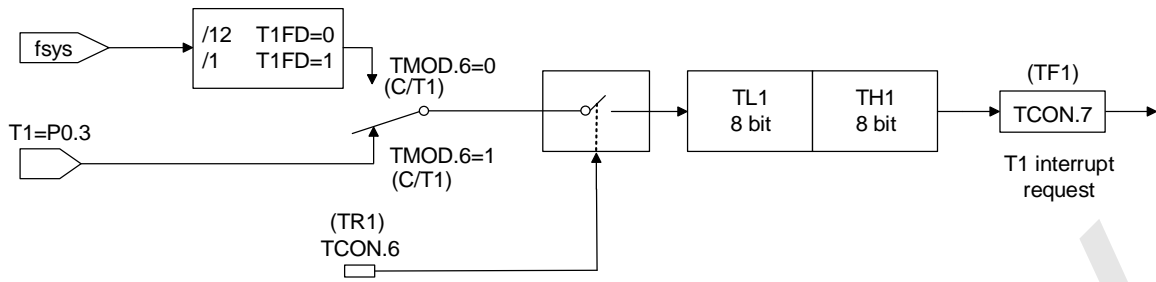

Timer/counter operating mode 1: 16-bit timer/counter

Operating mode 2: 8-bit Automatic Reload Counter/Timer

In operating mode 2, Timer 1 is an 8-bit auto-reload counter/timer. TL1 stores the count value, and TH1 stores the reload value. When the counter in TL1 overflows to 0x00, the timer overflow flag TF1 is set to 1, and the value of register TH1 is reloaded into register TL1. If the timer interrupt is enabled, an interrupt will be generated when TF1 is set to 1, but the reload value in TH1 will not change. Before allowing the timer to count correctly, TL1 must be initialized to the required value.

Except for the auto-reload function, the counter/timer in operating mode 2 is enabled and configured in the same way as modes 0 and 1.

When used as a timer, the register TMCON.1 (T1FD) can be configured to select the ratio of the timer clock source divided by the system clock fsys.

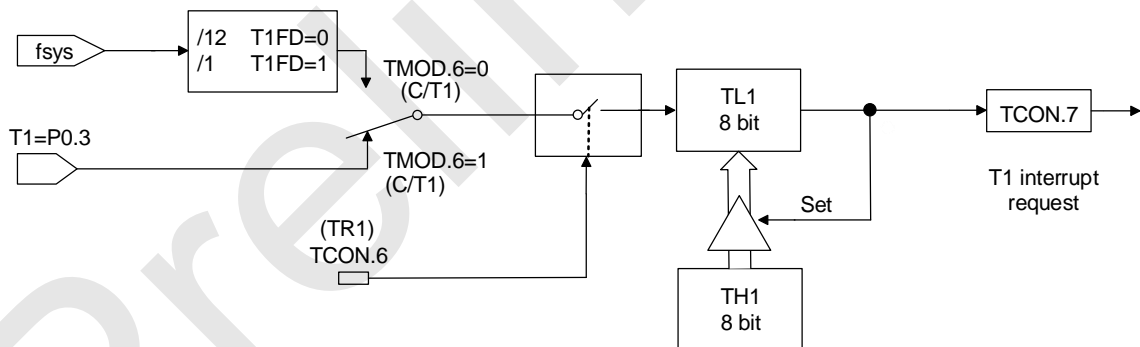

Timer/counter operating mode 2: 8-bit timer/counter with automatic reload

11 Timer/Counter T2/T3/T4

Timer 2/3/4 inside The SC95F861XB MCU are three independent Timers, among which Timer 2 has 4 operating modes, Timer 3 and Timer 4 have 1 operating mode.

The control registers of Timer 2/3/4 share the same set of addresses (C8H-CDH), users can point the Timer X register set (TXCON / TXMOD / RCAPXL / RCAPXH / TLX / THX) to Timer 2/3/4 through TXINX[2: 0]. In order to realize the function of three independent Timers configured by a group of registers.

Note: Only after the TXINX[2: 0] configuration is successful, the Timer X register group will point to the Timer 2/3/4 specified by the user. At this time, operating the TimeX register group is an effective operation for the corresponding Timer.

11.1 T2/3/4-related Registers

Symbol	Address	Description	7	6	5	4	3	2	1	0	POR
TXINX	CEH	Timer 2/3/4 control register pointer	-	-	-	-	-	TXINX[2: 0]			xxxxx010b
TXCON	C8H	Timer 2/3/4 control register	TFX	EXFX	RCLK X	TCL KX	EXEN X	TRX	C/TX	CP/RL X	00000000b
TXMOD	C9H	Timer 2/3/4 operating mode register	TXF D	-	EPW MN1	EPW MN0	INVN1	INVN 0	TXO E	DCXE N	0xxxxx00b
RCAPXL	CAH	Timer 2/3/4 reload low 8 bits	RCAPXL[7: 0]								00000000b
RCAPXH	CBH	Timer 2/3/4 reload high 8 bits	RCAPXH[7: 0]								00000000b
TLX	CCH	Timer 2/3/4 low 8 bits	TLX[7: 0]								00000000b
THX	CDH	Timer 2/3/4 high 8 bits	THX[7: 0]								00000000b
TMCON	8EH	Timer frequency control register	USMDX[1: 0]	-	-	-	-	T1FD	T0FD	00xxxx00b	

TXINX (CEH) Timer 2/3/4 Control Register Pointer (read/write)

Bit number	7	6	5	4	3	2	1	0
Bit Mnemonic	-	-	-	-	-	TXINX[2: 0]		
R/W	-	-	-	-	-	R/W	R/W	R/W
POR	x	x	x	x	x	0	1	0

Bit number	Bit Mnemonic	Description
2~0	TXINX[2: 0]	Timer 2/3/4 control register pointer 010: Timer X register set: TXCON / TXMOD / RCAPXL / RCAPXH / TLX / THX points to T2 011: Timer X register set points to T3 100: Timer X register set points to T4 Other: reserved
7~3	-	Reserved

11.2 Timer 2

Timer 2 inside the SC95F861XB MCU has two operating modes: counting mode and timing mode. There is a control bit C/TX in the special function register TXCON to select whether T2 is a timer or a counter. They are essentially an addition counter, but the source of the count is different. The source of the timer is the system clock or its divided clock, but the source of the counter is the input pulse of the external pin. TRX is the switch control of T2/T3/T4 counting in the timer/counter mode. Only when TRX=1, T2 will be opened for counting.

In counter mode, for every pulse on the T2 pin, the count value of T2 increases by 1 respectively.

In timer mode, the count source of T2 can be selected as $f_{sys}/12$ or f_{sys} through the special function register TXMOD.7 (TXFD).

Timer/counter T2 has 4 operating modes:

- ① Mode 0: 16-bit capture mode
- ② Mode 1: 16-bit auto-reload timer mode

③ Mode 2: Baud rate generator mode

④ Mode 3: Programmable clock output mod

TXINX[2: 0] = 010, the Timer X register group points to Timer 2, the explanation of each register is as follows:

TXCON (C8H) Timer 2 Control Register (read/write) (TXINX[2: 0] = 010)

Bit number	7	6	5	4	3	2	1	0
Bit Mnemonic	TFX	EXFX	RCLKX	TCLKX	EXENX	TRX	C/TX	CP/RLX
R/W	R/W	R/W	R/W	R/W	R/W	R/W	R/W	R/W
POR	0	0	0	0	0	0	0	0

Bit number	Bit Mnemonic	Description
7	TFX	Timer 2 overflow flag 0: No overflow (must be cleared by software) 1: Overflow (if RCLK = 0 and TCLK = 0, set by hardware 1)
6	EXFX	Flag bit detected by external event input (falling edge) of T2EX pin 0: No external event input (must be cleared by software) 1: External input detected (if EXENX = 1, set by hardware)
5	RCLKX	UART0 receive clock control bit 0: Timer 1 generates the receive baud rate 1: Timer 2 generates the receive baud rate
4	TCLKX	UART0 transmit clock control bit 0: Timer 1 generates transmission baud rate

		1: Timer 2 generates transmission baud rate
3	EXENX	T2EX pin is used as a reload/capture trigger enable/disable control: 0: Ignore events on T2EX pin 1: When Timer 2 is not used as the UART0 clock, a falling edge on the T2EX pin is detected, and a capture or reload is generated
2	TRX	Timer 2 start/stop control bit 0: stop timer 2/stop PWM2 counter 1: Start timer 2/start PWM2 counter
1	C/TX	Timer 2 Timer/counter mode selection positioning 2 0: Timer mode, T2 pin is used as I/O port 1: Counter mode
0	CP/RLX	Capture/reload mode selection positioning 0: 16-bit timer/counter with reload function 1: 16-bit timer/counter with capture function, TXEX is timer 2 external capture signal input port

TXMOD (C9H) Timer 2 Operating Mode Register (read/write) (TXINX[2: 0] = 010)

Bit number	7	6	5	4	3	2	1	0
Bit Mnemonic	TXFD	-	EPWM21	EPWM20	INV21	INV20	TXOE	DCXEN
R/W	R/W	-	R/W	R/W	R/W	R/W	R/W	R/W
POR	0	x	0	0	0	0	0	0

Bit number	Bit Mnemonic	Description
------------	--------------	-------------

7	TXFD	T2 input frequency selection control 0: T2 frequency is derived from fsys/12 1: T2 frequency is derived from fsys
1	TXOE	Timer 2 output enable bit 0: Set T2 as clock input or I/O port 1: Set T2 as the clock output
0	DCXEN	Count down enable bit 0: Timer 2 is prohibited as an up/down counter, Timer 2 is only used as an up counter 1: Allow Timer 2 as an up/down counter
6	-	Reserved

IE (A8H) Interrupt Enable Register (read/write)

Bit number	7	6	5	4	3	2	1	0
Bit Mnemonic	EA	EADC	ET2	EUART	ET1	EINT1	ET0	EINT0
R/W	R/W	R/W	R/W	R/W	R/W	R/W	R/W	R/W
POR	0	0	0	0	0	0	0	0

Bit number	Bit Mnemonic	Description
5	ET2	Timer 2 interrupt enable control 0: Disable Timer 2 interrupt 1: Enable Timer 2 interrupt

IP (B8H) Interrupt Priority Control Register (read/write)

Bit number	7	6	5	4	3	2	1	0
Bit Mnemonic	-	IPADC	IPT2	IPUART	IPT1	IPINT1	IPT0	IPINT0
R/W	-	R/W	R/W	R/W	R/W	R/W	R/W	R/W
POR	x	0	0	0	0	0	0	0

Bit number	Bit Mnemonic	Description
5	IPT2	Timer 2 interrupt priority 0: Set the interrupt priority of Timer 2 to "Low" 1: Set the interrupt priority of Timer 2 to "High"

11.3 Timer 3

Timer 3 inside the SC95F861XB MCU as a timer is essentially an addition counter. The clock source of the timer is the system clock or its divided clock. TRX is the switch control of T3 counting. Only when TRX=1, T3 will be opened to count.

In timer mode, the count source of T3 can be selected as $f_{sys}/12$ or f_{sys} through the special function register TXMOD.7 (TXFD).

TXINX[2: 0] = 011, the Timer X register group points to Timer 3, the explanation of each register is as follows:

TXCON (C8H) Timer 3 Control Register (read/write) (TXINX[2: 0] = 011)

Bit number	7	6	5	4	3	2	1	0
Bit Mnemonic	TFX	EXFX	-	-	EXENX	TRX	C/TX	CP/RLX
R/W	R/W	R/W	-	-	R/W	R/W	R/W	R/W

POR	0	0	x	x	0	0	0	0
-----	---	---	---	---	---	---	---	---

Bit number	Bit Mnemonic	Description
7	TFX	Timer 3 control register (read/write) Timer 3 overflow flag 0: No overflow (must be cleared by software) 1: Overflow (set by hardware 1)
6	EXFX	Flag bit detected by external event input (falling edge) of T3EX pin 0: No external event input (must be cleared by software) 1: External input detected (if EXENX = 1, set by hardware)
3	EXENX	T3EX pin is used as a reload/capture trigger enable/disable control: 0: Ignore events on T3EX pin 1: A falling edge on the T3EX pin is detected, and a capture or reload is generated
2	TRX	Timer 3 start/stop control bit 0: stop timer 3/stop PWM3 counter 1: Start timer 3/start PWM3 counter
1	C/TX	Timer 3 Timer/counter mode selection positioning 2 0: Timer mode, T3 pin is used as I/O port 1: Counter mode
0	CP/RLX	Capture/reload mode selection positioning 0: 16-bit timer/counter with reload function 1: 16-bit timer/counter with capture function, TXEX is timer 3 external capture signal input port
5~4	-	Reserved

TXMOD (C9H) Timer 3 Operating Mode Register (read/write) (TXINX[2: 0] = 011)

Bit number	7	6	5	4	3	2	1	0
Bit Mnemonic	TXFD	-	EPWM31	EPWM30	INV31	INV30	TXOE	DCXEN
R/W	R/W	-	R/W	R/W	R/W	R/W	R/W	R/W
POR	0	x	0	0	0	0	0	0

Bit number	Bit Mnemonic	Description
7	TXFD	T3 input frequency selection control 0: T3 frequency is derived from fsys/12 1: T3 frequency is derived from fsys
1	TXOE	Timer 3 output enable bit 0: Set T3 as clock input or I/O port 1: Set T3 as the clock output
0	DCXEN	Count down enable bit 0: Timer 3 is prohibited as an up/down counter, Timer 3 is only used as an up counter 1: Allow Timer 3 as an up/down counter, T3EX is used to select the counting direction
6	-	Reserved

IE1 (A9H) Interrupt Enable Register 1 (read/write)

Bit number	7	6	5	4	3	2	1	0
Bit Mnemonic	ET4	ET3	ECMP	ETK	EINT2	EBTM	EPWM	EUSCIO
R/W	R/W	R/W	R/W	R/W	R/W	R/W	R/W	R/W
POR	0	0	0	0	0	0	0	0

Bit number	Bit Mnemonic	Description
6	ET3	Timer 3 interrupt enable control 0: Disable Timer 3 interrupt 1: Enable Timer 3 interrupt

IP1 (B9H) Interrupt Priority Control Register 1 (read/write)

Bit number	7	6	5	4	3	2	1	0
Bit Mnemonic	IPT4	IPT3	IPCMP	IPTK	IPINT2	IPBTM	IPPWM	IPUSCIO
R/W	R/W	R/W	R/W	R/W	R/W	R/W	R/W	R/W
POR	0	0	0	0	0	0	0	0

Bit number	Bit Mnemonic	Description
6	IPT3	Timer 3 interrupt priority selection 0: Timer 3 interrupt priority is low

		1: Timer 3 interrupt priority is high
--	--	---------------------------------------

11.4 Timer 4

Timer 4 inside the SC95F861XB MCU as a timer is essentially an addition counter. The clock source of the timer is the system clock or its divided clock. TRX is the switch control of T4 count. Only when TRX=1, T4 will be turned on and counted.

In timer mode, the count source of T4 can be selected as $f_{sys}/12$ or f_{sys} through the special function register TXMOD.7 (TXFD).

TXINX[2: 0] = 100, Timer X register group points to Timer 4, the explanation of each register is as follows:

TXCON (C8H) Timer 4 Control Register (read/write) (TXINX[2: 0] = 100)

Bit number	7	6	5	4	3	2	1	0
Bit Mnemonic	TFX	EXFX	-	-	EXENX	TRX	C/TX	CP/RLX
R/W	R/W	R/W	-	-	R/W	R/W	R/W	R/W
POR	0	0	x	x	0	0	0	0

Bit number	Bit Mnemonic	Description
7	TFX	Timer 4 overflow flag 0: No overflow (must be cleared by software) 1: Overflow (set by hardware 1)
6	EXFX	Flag bit detected by external event input (falling edge) of T4EX pin 0: No external event input (must be cleared by software) 1: External input detected (if EXENX = 1, set by hardware)
3	EXENX	T4EX pin is used as a reload/capture trigger enable/disable control: 0: Ignore events on T4EX pin

		1: A falling edge on the T4EX pin is detected, and a capture or reload is generated
2	TRX	Timer 4 start/stop control bit 0: stop timer 4/stop PWM4 counter 1: Start timer 4/start PWM4 counter
1	C/TX	Timer 4 Timer/counter mode selection positioning 2 0: Timer mode, T4 pin is used as I/O port 1: Counter mode
0	CP/RLX	Capture/reload mode selection positioning 0: 16-bit timer/counter with reload function 1: 16-bit timer/counter with capture function, TXEX is timer 4 external capture signal input port
5~4	-	Reserved

TXMOD (C9H) Timer 4 Operating Mode Register (read/write) (TXINX[2: 0] = 100)

Bit number	7	6	5	4	3	2	1	0
Bit Mnemonic	TXFD	-	EPWM41	EPWM40	INV41	INV40	TXOE	DCXEN
R/W	R/W	-	R/W	R/W	R/W	R/W	R/W	R/W
POR	0	x	0	0	0	0	0	0

Bit number	Bit Mnemonic	Description
7	TXFD	T4 input frequency selection control

		0: T4 frequency is derived from fsys/12 1: T4 frequency is derived from fsys
1	TXOE	Timer 4 output enable bit 0: Set T4 as clock input or I/O port 1: Set T4 as the clock output
0	DCXEN	Count down enable bit 0: Timer 4 is prohibited as an up/down counter, Timer 4 is only used as an up counter 1: Allow Timer 4 as an up/down counter, T4EX is used to select the counting direction
6	-	Reserved

IE1 (A9H) Interrupt Enable Register 1 (read/write)

Bit number	7	6	5	4	3	2	1	0
Bit Mnemonic	ET4	ET3	ECMP	ETK	EINT2	EBTM	EPWM	EUSCIO
R/W	R/W	R/W	R/W	R/W	R/W	R/W	R/W	R/W
POR	0	0	0	0	0	0	0	0

Bit number	Bit Mnemonic	Description
7	ET4	Timer 4 interrupt enable control 0: Disable Timer 4 interrupt 1: Enable Timer 4 interrupt

IP1 (B9H) Interrupt Priority Control Register 1 (read/write)

Bit number	7	6	5	4	3	2	1	0
Bit Mnemonic	IPT4	IPT3	IPCMP	IPTK	IPINT2	IPBTM	IPPWM	IPUSCIO
R/W	R/W	R/W	R/W	R/W	R/W	R/W	R/W	R/W
POR	0	0	0	0	0	0	0	0

Bit number	Bit Mnemonic	Description
6	IPT4	Timer 4 interrupt priority selection 0: Timer 4 interrupt priority is low 1: Timer 4 interrupt priority is high

11.5 Timer 2/3/4 Operating Modes

Timer 2/3/4's operating modes as follows:

- ① Mode 0: 16-bit capture
- ② Mode 1: 16-bit auto-reload timer
- ③ Mode 2: Baud rate generator, only Timer 2 support this mode
- ④ Mode 3: Programmable clock output
- ⑤ Mode 4: PWM output mode

The preceding working modes and configuration modes are listed as follows:

C/TX	TXOE	DCXEN	TRX	CP/RLX	EXENX	Mode	
X	0	X	1	1	1	Mode 0	16-bit capture

X	0	0	1	0	0	Mode 1	16-bit auto-reload timer/counter, normally auto-reload
X	0	0	1	0	1		16-bit auto-reload timer/counter, with TnEX trigger reload
X	0	1	1	0	X		16-bit auto-reload timer/counter, increase or decrease reload
X	0	X	1	X	X	Mode 2	UART0 Baud rate generator, only for Timer 2
0	1	X	1	X	X	Mode 3	Programmable clock output
X	X	X	0	X	1	X	Timer stops, TnEX(n=2~4) channel is still allowed

11.5.1 Timer 2/3/4 Operating Modes

Operating Mode 0: 16-bit Capture

CP/RLX = 1, set Timer n(n=2~4) to 16-bit capture

In the capture mode, the EXENX bit of TXCON has two options:

If EXENX = 0, Timer n acts as a 16-bit timer or counter. If ETn is enabled, Timer n can set TFX overflow to generate an interrupt.

If EXENX = 1, Timer n performs the same operation, but the falling edge on external input TnEX can also cause the current values in THX and TLX to be captured in RCAPXH and RCAPXL, respectively. In addition, the falling edge on TnEX also can cause EXFX in TXCON to be set. If ETn is enabled, the EXFX bit also generates an interrupt like TFX.

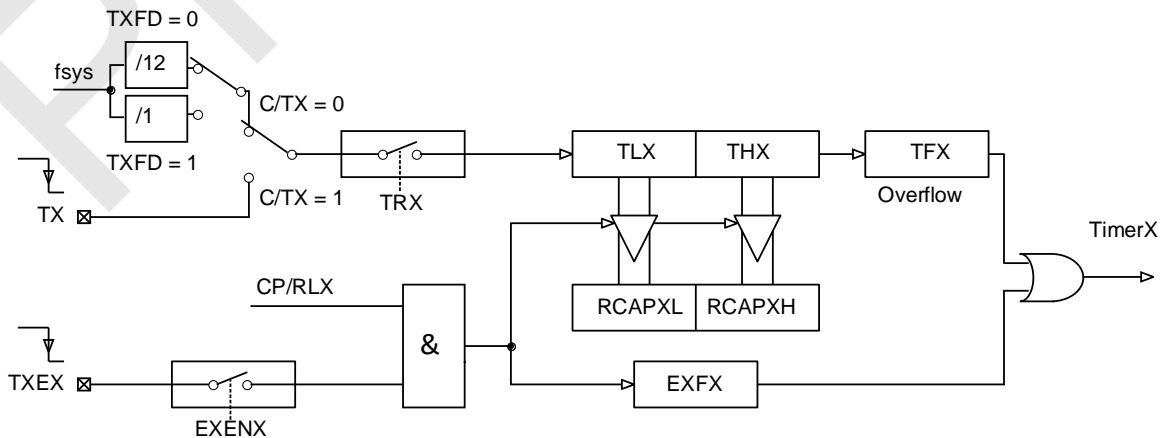

Mode 0: 16-bit capture

Operating Mode 1: 16-bit Auto-Reload Timer

In 16-bit auto-reload mode, Timer n(n=2~4) can be selected to count up or count down. This function is selected by the DCEN bit (down counting allowed) in TnMOD. After the system is reset, the reset value of the DCEN bit is 0, and the timer n counts up by default. When DCEN is set to 1, Timer n counts up or down depending on the level on the TnEX pin.

When DCEN = 0, two options are selected through the EXENX bit in TXCON.

If EXENX = 0, Timer n increments to 0xFFFFH, sets the TFX bit after overflow, and the timer automatically loads the 16-bit values of registers RCAPXH and RCAPXL written in user software into the THX and TLX registers.

If EXENX = 1, an overflow or a falling edge on TnEX can trigger a 16-bit reload and set the EXFX bit. If ETn is enabled, both TFX and EXFX bits can generate an interrupt.

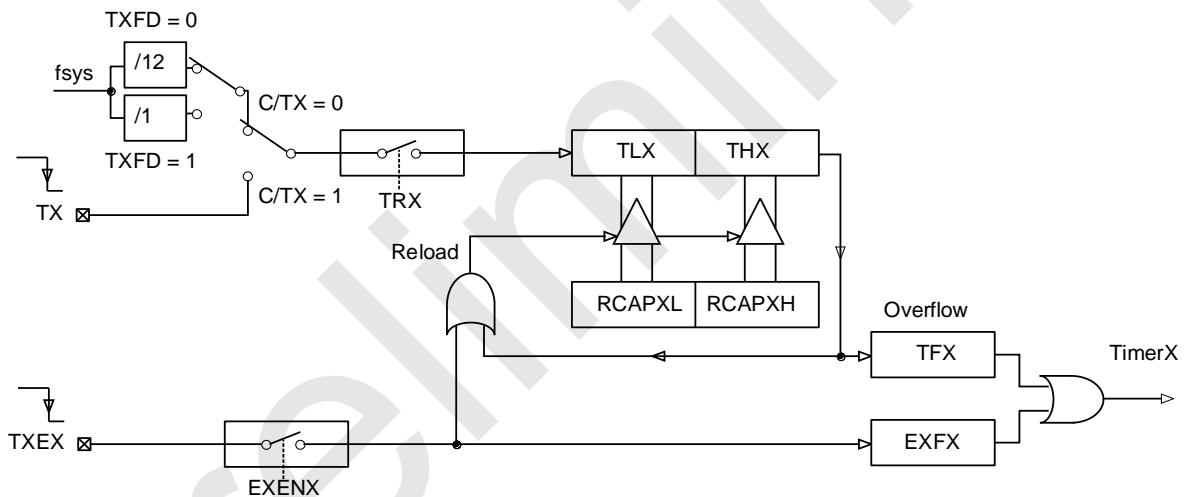

Mode 1: 16-bit auto-reload DCEN = 0

Setting the DCEN bit allows Timer n to count up or down. When DCEN = 1, the TnEX pin controls the direction of the count, and EXENX control is invalid.

Setting TnEX causes Timer n to count up. The timer overflows to 0xFFFFH, and then sets the TFX bit. Overflow can also cause the 16-bit values on RCAPXH and RCAPXL to be reloaded into the timer register, respectively.

Setting TnEX to 0 causes Timer n to count down. When the values of THX and TLX are equal to the values of RCAPXH and RCAPXL, the timer overflows. The TFX bit is set and 0xFFFFH is reloaded into the timer register.

Regardless of whether Timer n overflows or not, the EXFX bit is used as the 17th bit of the result. In this operating mode, EXFX is not used as an interrupt flag.

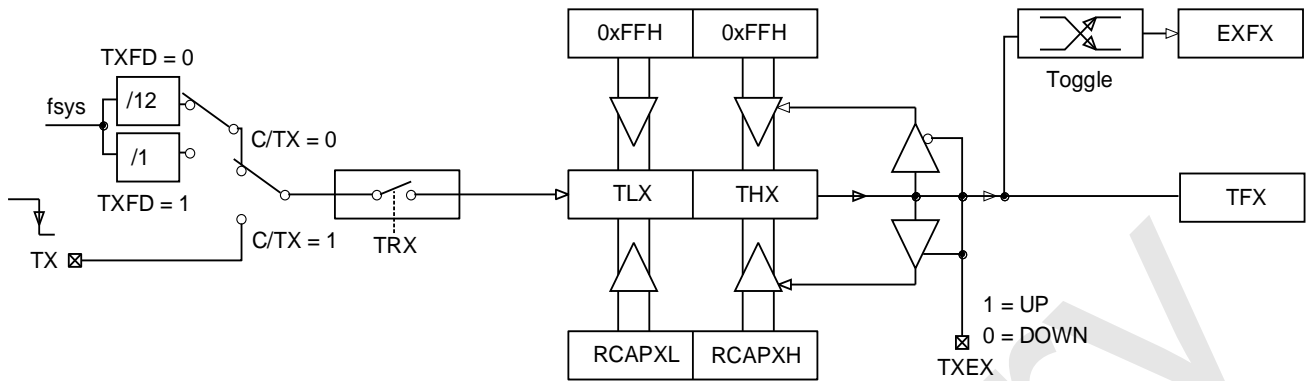

Mode 1: 16-bit auto-reload DCEN = 1

Operating Mode 2: Baud Rate Generator, only for Timer 2

Set TCLK and/or RCLK in the TXCON register to select Timer 2 as the baud rate generator. The baud rate of the receiver and transmitter can be different. If Timer 2 acts as a receiver or transmitter, then Timer 1 acts as another baud rate generator

Set TCLK and/or RCLK in the TXCON register to make Timer 2 enter the baud rate generator mode, which is similar to the automatic reload mode

The overflow of Timer 2 will reload the values in the RCAPXH and RCAPXL registers to the Timer 2 count, but no interrupt will be generated

If EXENX is set to 1, the falling edge on the T2EX pin will set up EXFX, but it will not cause a heavy load. So when Timer 2 is used as a baud rate transmitter, T2EX can be used as an additional external interrupt

The baud rate in UART0 mode 1 and 3 is determined by the overflow rate of timer 2 according to the following equation:

$$\text{BaudRate} = \frac{f_{\text{sys}}}{[\text{RCAPXH}, \text{RCAPXL}]}; \text{ (Note: } [\text{RCAPXH}, \text{RCAPXL}] \text{ must be bigger than } 0\text{x}0010\text{)}$$

The schematic diagram of Timer 2 as a baud rate generator is as follows:

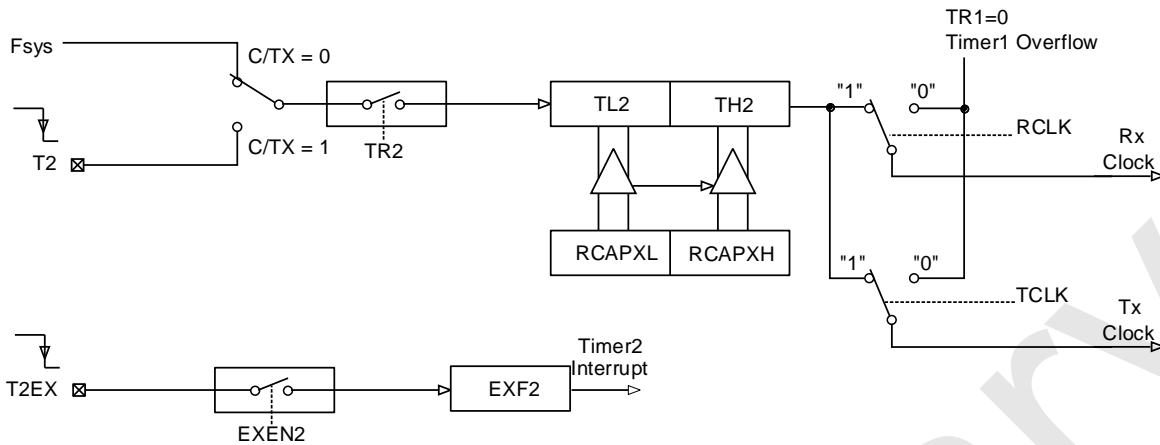

Mode 2: Baud rate generator

Operating Mode 3: Programmable Clock Output

In this way, Timer n(n=2~4) can be programmed to output a 50% duty cycle clock cycle: when $C/\overline{Tn} = 0$; $TnOE = 1$, timer n is enabled as a clock generator

In this way, Tn outputs a clock with a 50% duty cycle

$$\text{Clock Out Frequency} = \frac{f_n}{(65536 - [RCAPXH, RCAPXL]) \times 4};$$

Among them, f_n is the timer n clock frequency:

$$f_n = \frac{f_{sys}}{12}; \quad TXFD = 0$$

$$f_n = f_{sys}; \quad TXFD = 1$$

Timer n overflow does not generate an interrupt, and the Tn port is used as a clock output.

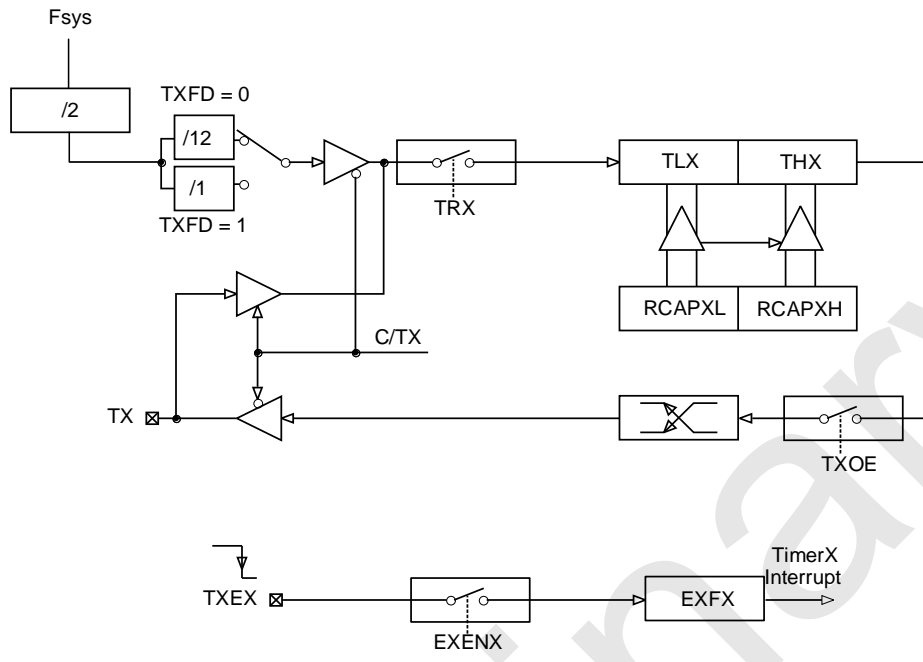

Mode 3: Programmable clock output

Note:

1. Both TFX and EXFX can cause the interrupt request of Timer n(n=2~4), both have the same vector address;
2. When the event occurs or at any other time, TFX and EXFX can be set to 1 by software, and only software and hardware reset can clear it to 0;
3. When EA = 1 and ETn = 1, setting TFX or EXFX to 1 can cause Timer n to interrupt;
4. When Timer n is used as a baud rate generator, writing THX/TLX or RCAPXH/RCAPXL will affect the accuracy of the baud rate and cause communication errors.

12 PWM2/3/4

The SC95F861XB provides up to 14 PWM, which divided into two categories:

1. Multi-function PWM: 8 channels for only one group PWM0, output signal port: PWM00~07
2. Conventional PWM: 6 channels divided into 3 groups: PWM2, PWM3, PWM4. **Note: These three sets of PWM period registers are shared with the TLX and THX of Timer2, Timer3, and Timer4 respectively. Therefore, once users use the PWM2, PWM3, and PWM4 resources, they cannot change the timing/count value of Timer2, Timer3, and Timer4. Otherwise it will lead to abnormal OUTPUT of PWM cycle!**

12.1 PWM2/3/4 related Registers

TXINX (CEH) Timer 2/3/4 Control Register Pointer (read/write)

Bit number	7	6	5	4	3	2	1	0
Bit Mnemonic	-	-	-	-	-	TXINX[2: 0]		
R/W	-	-	-	-	-	R/W	R/W	R/W
POR	x	x	x	x	x	0	1	0

Bit number	Bit Mnemonic	Description
2~0	TXINX[2: 0]	Timer 2/3/4 control register pointer 010: Timer X register set: TXCON / TXMOD / RCAPXL / RCAPXH / TLX / THX points to PWM2 011: Timer X register set points to PWM3 100: Timer X register set points to PWM4 Other: reserved
7~3	-	Reserved

TXCON (C8H) Timer n Control Register (read/write)

Bit number	7	6	5	4	3	2	1	0
Bit Mnemonic	TFX	EXFX	RCLKX	TCLKX	EXENX	TRX	C/TX	CP/RLX
R/W	R/W	R/W	R/W	R/W	R/W	R/W	R/W	R/W
POR	0	0	0	0	0	0	0	0

Bit number	Bit Mnemonic	Description
2	TRX	Timer n start/stop control bit 0: stop timer n/stop PWMn counter 1: Start timer n/start PWMn counter

When EPWMn0 or EPWMn1 is set to 1, the Timer can start PWM mode, Tn and TnEX (n= 2~4) are invalid, and PWMxy (x= 2~4, y=0~1) can output PWM waveform.

TXMOD (C9H) Timer 2 Operating Mode Register (read/write) (TXINX[2: 0] = 010)

Bit number	7	6	5	4	3	2	1	0
Bit Mnemonic	TXFD	-	EPWM21	EPWM20	INV21	INV20	TXOE	DCXEN
R/W	R/W	-	R/W	R/W	R/W	R/W	R/W	R/W
POR	0	x	0	0	0	0	0	0

Bit number	Bit Mnemonic	Description
5	ENPWMn1	PWMn1 Waveform output select 0: PWMn1 output is disabled

		1: I/O where PWMn1 resides serves as the output port of the PWM waveform
4	ENPWMn0	PWMn0 Waveform output select 0: PWMn0 output is disabled 1: I/O where PWMn0 resides serves as the output port of the PWM waveform
3	INVn1	PWMn1 waveform output reverse control 1: PWMn1 waveform output is reversed 0: PWMn1 waveform output is not reversed
2	INVn0	PWMn0 waveform output reverse control 1: PWMn0 waveform output is reversed 0: PWMn0 waveform output is not reversed

The THX and TLX counter starts counting from 0, and when the count value matches the value of the duty cycle setting item PDTxy [15: 0], the PWM output waveform switches between high and low levels, The THX and TLX counter then continues counting upward reload value PWMPDX, then THX and TLX counter is cleared and generate count overflow events and a PWM cycle ends. If the timer interrupt is enabled, a timer interrupt will be generated at this time.

The calculation formula of PWM period T_{PWM} output by Timer is as follows:

$$T_{pwm} = \frac{PWMPDX[15:0] + 1}{f_{sys}}$$

Duty calculation formula:

$$duty = \frac{PDTxy [15:0]}{PWMPDX[15:0] + 1}$$

The PWM cycle is set through the following registers:

RCAPXH (CBH)

PWMn period register high 8 bits(R/W)

Note: The PWM2/3/4 cycle register is multiplexed with Timer2, Timer3, and Timer4. Therefore, once users use the PWM2, PWM3, and PWM4 resources, they cannot change the timer/counter value of Timer2, Timer3, and Timer4. Otherwise, the PWM cycle output will be abnormal!

Bit number	7	6	5	4	3	2	1	0
-------------------	---	---	---	---	---	---	---	---

Bit Mnemonic	PWMPDHX[7:0]							
R/W	R/W	R/W	R/W	R/W	R/W	R/W	R/W	R/W
POR	0	0	0	0	0	0	0	0

RCAPXL (CAH)
PWMn period register low 8 bits (R/W) (TXINX[2:0] = 010)

Note: The PWM2/3/4 cycle register is multiplexed with Timer2, Timer3, and Timer4. Therefore, once users use the PWM2, PWM3, and PWM4 resources, they cannot change the timer/counter value of Timer2, Timer3, and Timer4. Otherwise, the PWM cycle output will be abnormal!

Bit number	7	6	5	4	3	2	1	0
Bit Mnemonic	PWMPDLX[7:0]							
R/W	R/W	R/W	R/W	R/W	R/W	R/W	R/W	R/W
POR	0	0	0	0	0	0	0	0

Bit number	Bit Mnemonic	Description
7~0	PWMPDX[15:0]	PWMn cycle set This value represents the output waveform of PWMn (cycle-1); that is to say PWMn cycle of output is(PWMPDX[15:0] + 1) * PW clock

The PWM duty is set through the following registers:

PWM2~4 Duty cycle adjustment register (R/W)

ADD	7	6	5	4	3	2	1	0	POR
2034H	PDT20[15:8]								0000000b
2035H	PDT20[7:0]								0000000b
2036H	PDT21[15:8]								0000000b
2037H	PDT21[7:0]								0000000b
2038H	PDT30[15:8]								0000000b
2039H	PDT30[7:0]								0000000b
203AH	PDT31[15:8]								0000000b
203BH	PDT31[7:0]								0000000b
203CH	PDT40[15:8]								0000000b

203DH	PDT40[7:0]	00000000b
203EH	PDT41[15:8]	00000000b
203FH	PDT41[7:0]	00000000b

Bit number	Bit Mnemonic	Description
7~0	PDTxy[15:0] (x=2~4, y=0~1)	PWMxy waveform duty cycle length setting The high level width of the PWMxy waveform is: (PDTxy[15:0] + 1) PWM clock

12.2 PWM2/3/4 Duty Variation Characteristics

The duty can be changed by changing the high level setting register PDTxy (x=2~4, y=0~1) when PWM2/3/4 output waveform. However, it should be noted that if you change the PDTxy value, the duty will not change immediately, but wait until the end of this cycle and change in the next cycle.

12.3 PWM2/3/4 Cycle Variation Characteristics

If you need to change the period when the PWM2/3/4 outputs the waveform, you can set the TLX and THX values of the register groups by changing the period. Change the value of the cycle register, the PWM output cycle changes as follows:

Define the current period meter value as T_n , when writing the period register, the value recorded by the timer is T_m , and the period meter value to be updated is T_x , then:

$T_m \leq T_x$: the period changes in real time according to T_x ;

$T_m > T_x$: At this point, the cycle change will be divided into two stages. In the first stage, after writing to the cycle register, the cycle counter accumulates from the current count until overflow is cleared. In the second phase, the period changes with respect to T_x .

13 PWM0

The SC95F861XB provides up to 14 PWM, which divided into two categories:

3. Multi-function PWM: 8 channels for only one group PWM0, output signal port: PWM00~07
4. Conventional PWM: 6 channels divided into 3 groups: PWM2, PWM3, PWM4. **Note: These three sets of PWM period registers are shared with the TLX and THX of Timer2, Timer3, and Timer4 respectively. Therefore, once users use the PWM2, PWM3, and PWM4 resources, they cannot change the timing/count value of Timer2, Timer3, and Timer4. Otherwise it will lead to abnormal OUTPUT of PWM cycle!**

The functions of the PWM0 of the SC95F861XB are as follows:

1. 16-bit PWM accuracy;
2. The output waveform can be reversed;
3. Type: Can be set to center-aligned or edge-aligned;
4. Mode: can be set to independent mode or complementary mode:
 - a) In independent mode, the 8 PWM cycles are the same, but the duty cycle of each PWM output waveform can be set separately;
 - b) In complementary mode, four sets of complementary PWM waveforms with dead zones can be output simultaneously;
5. Provide one PWM overflow interrupt;
6. Support fault detection mechanism.

The PWM of the SC95F861XB can support the adjustment of period and duty cycle. The registers PWMCFG, PWMCON0 and PWMCON1 control the state and period of PWM. The opening of each PWM and the output waveform duty cycle can be adjusted separately.

13.1 PWM Structure Diagram

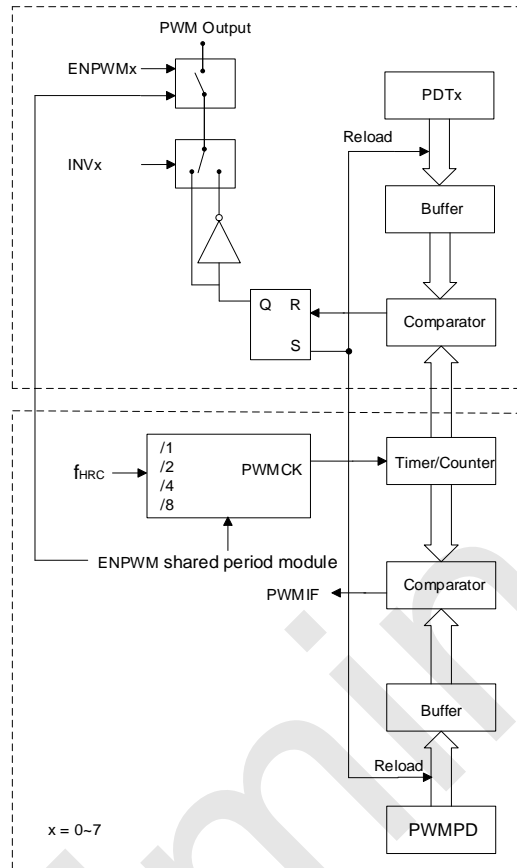

SC95F861XB PWM Structure diagram

13.2 PWM0 General Configuration Register

13.2.1 PWM0 General Configuration Register

The user can set the PWM output mode of SC95F861XB to independent mode or complementary mode by configuring PWMMMD[1: 0]. In independent mode, the 8 PWM cycles are the same, but the duty cycle of each PWM output waveform can be set separately. In complementary mode, four complementary PWM waveforms with dead zones can be output simultaneously.

The PWM type of SC95F861XB is divided into edge-aligned type and center-aligned type:

Edge-aligned:

The PWM counter starts counting from 0, and when the count value matches the value of the duty cycle setting item PDTxy [15: 0], the PWM output waveform switches between high and low levels. The PWM counter then continues counting upward until it matches the value of the period setting PWMPD[15:0] + 1 (the end of a PWM period), the PWM counter is cleared, if the PWM interrupt is enabled, a PWM interrupt will be generated at this time.

The output PWM waveform is aligned on the left edge.

Calculation formula of edge-aligned period T_{PWM} :

$$T_{pwm} = \frac{PWMPD[15: 0] + 1}{PWM \text{ Clock frequency}}$$

Edge-aligned **duty** calculation formula:

$$duty = \frac{PDTxy [15: 0]}{PWMPD[15: 0] + 1}$$

The edge-aligned waveform is as follows:

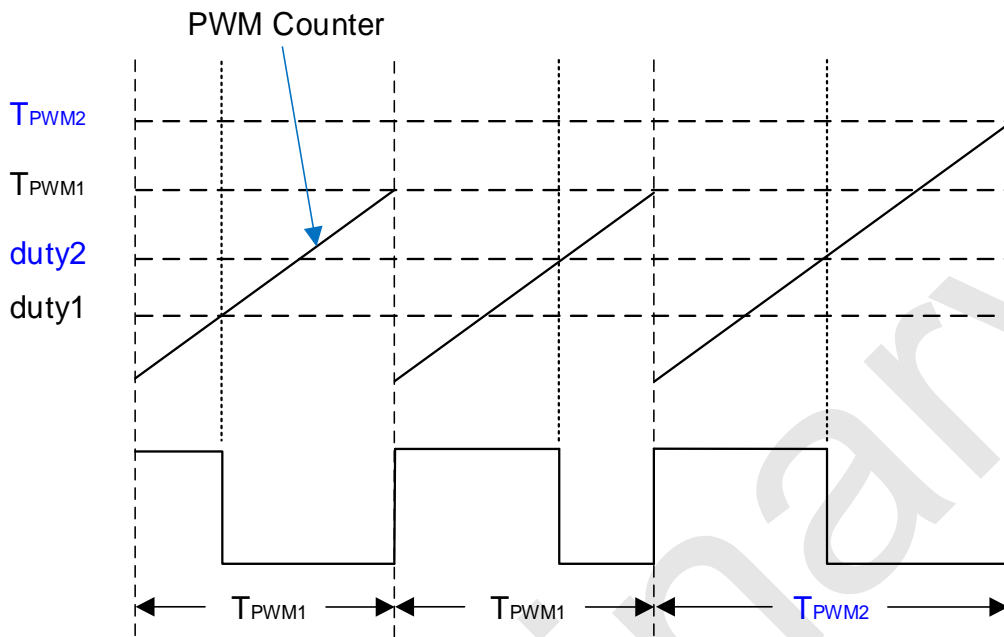

Edge-aligned PWM

Center-aligned type:

The PWM counter starts counting from 0. When the count value matches the value of the duty cycle setting item $PDTxy [15: 0]$, the PWM output waveform switches between high and low levels. Then the PWM counter continues to count up. When the count matches the value of $PWMPD[15:0] + 1$ (that is, the midpoint of the PWM cycle), it automatically starts to count down. When the count value matches the value of $PDTxy [15: 0]$ again, the PWM output waveform switches high and low again, and then The PWM counter continues to count down until it overflows (the end of a PWM period). If the PWM interrupt is enabled, a PWM interrupt will be generated at this time.

Calculation formula of center-aligned period T_{PWM} :

$$T_{pwm} = 2 * \frac{PWMPD[15: 0] + 1}{PWM \text{ Clock frequency}}$$

Center-aligned **duty** calculation formula:

$$duty = \frac{PDTxy [15: 0]}{PWMPD[15: 0] + 1}$$

The center aligned waveform is as follows:

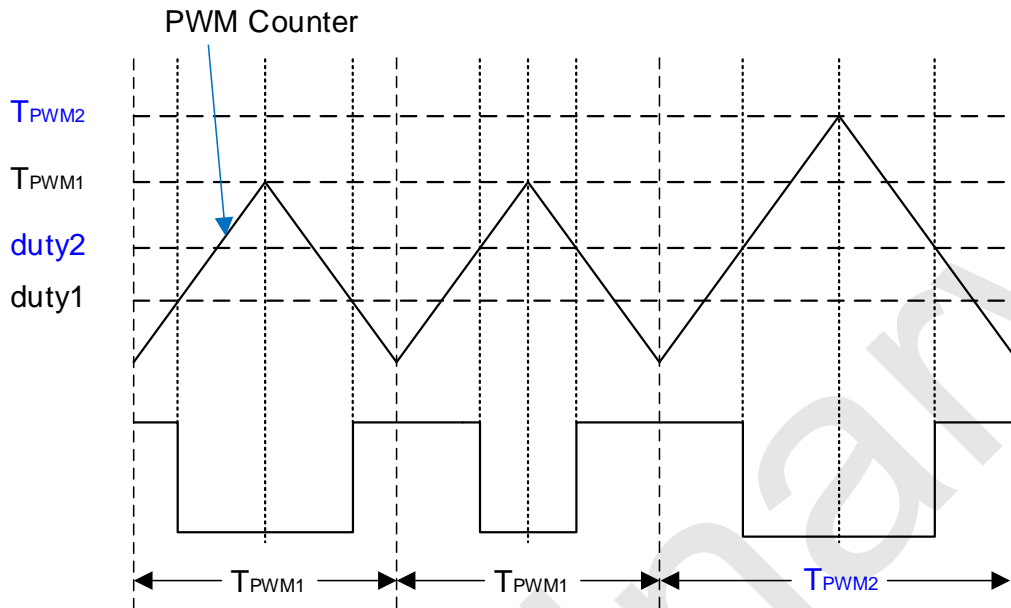

Center-aligned PWM

The above modes and types can be set through the PWMMOD register:

PWMCON0 (D2H) PWM Control Register (read/write)

Bit number	7	6	5	4	3	2	1	0
Bit Mnemonic	ENPWM	PWMIF	PWMCK[1:0]		-	-	PWMMD[1:0]	
R/W	R/W	R/W	R/W	R/W	R/W	R/W	R/W	R/W
POR	0	0	0	0	x	x	0	0

Bit number	Bit Mnemonic	Description
7	ENPWM	PWM module switch control (Enable PWM) 1: Allow Clock to enter the PWM unit, the PWM is in the operating state, and the state of the PWM output port is controlled by the register ENPWMx (x=0~7)

		0: The PWM unit stops operating, the PWM counter is cleared, and all PWM output ports are set to the GPIO state
6	PWMIF	<p>PWM interrupt request flag</p> <p>When the PWM counter overflows (that is, when the count exceeds PWMPD), this bit is automatically set to 1 by the hardware. If IE1[1] (EPWM) is also set to 1, the PWM interrupt is generated at this time. After the PWM interrupt occurs, the hardware will not automatically clear this bit. This bit must be cleared by the user's software.</p>
5~4	PWMCK[1: 0]	<p>PWM Clock Source Selector (PWM Clock Source Selector)</p> <p>00: f_{HRC}</p> <p>01: $f_{HRC} / 2$</p> <p>10: $f_{HRC} / 4$</p> <p>11: $f_{HRC} / 8$</p> <p>The frequency of the PWM clock source is fixed at $f_{HRC} = 32 \text{ MHz}$</p>
1~0	PWMMD[1: 0]	<p>PWM operating mode setting</p> <p>0x: Independent mode</p> <p>1x: complementary mode</p> <p>x0: edge alignment mode</p> <p>x1: center alignment mode</p>
3~2	-	Reserved

PWMCFG (D1H) PWM Set Register (read/write)

Bit number	7	6	5	4	3	2	1	0
Bit Mnemonic	INV7	INV6	INV5	INV4	INV3	INV2	INV1	INV0
R/W	R/W	R/W	R/W	R/W	R/W	R/W	R/W	R/W

POR	0	0	0	0	0	0	0	0
-----	---	---	---	---	---	---	---	---

Bit number	Bit Mnemonic	Description
7~0	INVx(x=0~7)	PWMx waveform output reverse control 1: PWMx waveform output is reversed 0: PWMx waveform output is not reversed

PWMCON1 (D3H) PWM Control Register (read/write)

Bit number	7	6	5	4	3	2	1	0
Bit Mnemonic	ENPWM 7	ENPWM 6	ENPWM 5	ENPWM 4	ENPWM 3	ENPWM 2	ENPWM 1	ENPWM 0
R/W	R/W	R/W	R/W	R/W	R/W	R/W	R/W	R/W
POR	0	0	0	0	0	0	0	0

Bit number	Bit Mnemonic	Description
7~0	ENPWMx (x=0~7)	PWMx Waveform output select 0: PWMx output is disabled 1: I/O where PWMx resides serves as the output port of the PWM waveform

Note:

1. If ENPWM is set to 1, the PWM module is turned on, but ENPWMx=0, and the PWM output is turned off as a GPIO port. In this case, the PWM module can be used as a 16-bit Timer. When EPWM(IE1.1) is set to 1, the PWM will still interrupt.

PWMPDL (D4H) period register low 8 bits(R/W)

Bit number	7	6	5	4	3	2	1	0
Bit Mnemonic	PWMPDL[7:0]							
R/W	R/W	R/W	R/W	R/W	R/W	R/W	R/W	R/W
POR	0	0	0	0	0	0	0	0

PWMPDH (D5H)PWMn period register high 8 bits (R/W)

Bit number	7	6	5	4	3	2	1	0
Bit Mnemonic	PWMPDH[7:0]							
R/W	R/W	R/W	R/W	R/W	R/W	R/W	R/W	R/W
POR	0	0	0	0	0	0	0	0

Bit number	Bit Mnemonic	Description
7~0	PWMPD[15:0]	PWM cycle set This value represents the output waveform of PWMn (cycle-1); that is to say PWMn cycle of output is(PWMPDX[15:0] + 1) * PW clock

IE1 (A9H) Interrupt Enable Register (read/write)

Bit number	7	6	5	4	3	2	1	0
Bit Mnemonic	ET4	ET3	ECMP	ETK	EINT2	EBTM	EPWM	EUSCIO
R/W	R/W	R/W	R/W	R/W	R/W	R/W	R/W	R/W
POR	0	0	0	0	0	0	0	0

Bit number	Bit Mnemonic	Description
------------	--------------	-------------

1	EPWM	PWM interrupt enable control 0: Disable PWM interrupt 1: Enable interrupt when PWM counter overflows
---	-------------	--

IP1 (B9H) Interrupt Priority Register 1 (read/write)

Bit number	7	6	5	4	3	2	1	0
Bit Mnemonic	IPT4	IPT3	IPCMP	IPTK	IPINT2	IPBTM	IPPWM	IPUSCIO
R/W	R/W	R/W	R/W	R/W	R/W	R/W	R/W	R/W
POR	0	0	0	0	0	0	0	0

Bit number	Bit Mnemonic	Description
1	IPPWM	PWM interrupt priority selection 0: Set the PWM interrupt priority to "low" 1: Set the PWM interrupt priority to "High"

13.2.2 PWM0 Fault Detection Function Setting

The fault detection function is often applied to the protection of motor systems. When the fault detection function is enabled, FLTEN1 (PWMFLT.7) is set to 1, and the fault detection signal input pin (FLT) becomes effective. When the signal of the FLT pin meets the fault condition, the flag bit FLTSTA1 is set by hardware, and the PWM output stops. The PWM counter still keeps counting and THE PWM interrupt is not affected. The fault detection mode is divided into latch mode and immediate mode; in immediate mode, when the fault signal on the FLT pin meets the disabling condition, the flag FLTSTA1 is cleared by hardware, and until the PWM counter returns to zero. Output; In the latch mode, when the fault signal on the FLT pin meets the disabling condition, the status of the FLTSTA1 flag remains unchanged, and the user can clear it through software. Once the FLTSTA1 status is cleared, the PWM counter resumes counting until the PWM counter returns The PWM resumes output after zero. The fault detection mode is divided into latch mode and immediate mode. The specific configuration methods are as follows:

PWMFLT (D7H) PWM Fault Detection Setting Register (read/write)

Bit number	7	6	5	4	3	2	1	0
Bit Mnemonic	FLTEN1	FLTSTA1	FLTMD1	FLTLV1	-	-	FLTDT1[1: 0]	
R/W	R/W	R/W	R/W	R/W	-	-	R/W	R/W
POR	0	0	0	0	x	x	0	0

Bit number	Bit Mnemonic	Description
7	FLTEN1	PWM fault detection function control bit 0: The fault detection function is turned off 1: The fault detection function is turned on
6	FLTSTA1	PWM fault detection status flag 0: PWM is in normal output state; 1: Fault detection is valid, the PWM output is in a high-impedance state, if in latch mode, this bit can be cleared by software
5	FLTMD1	PWM fault detection mode setting bit 0: Latch mode: when the fault input is valid, FLTSTA1 is set to "1", the PWM stops outputting, and the FLTSTA1 state remains unchanged when the fault input is invalid 1: Immediate mode: When the fault input is valid, FLTSTA1 is set to "1" and the PWM stops outputting. When the fault input is invalid, the state of FLTSTA1 is cleared immediately, and the PWM waveform will resume output when the PWM time base counter count to zero
4	FLTLV1	PWM fault detection level selection bit 0: Low level of fault detection is effective 1: High level of fault detection is effective
1~0	FLTDT1[1: 0]	PWM fault detection input signal filtering time setting

		00: filtering time is 0 01: filtering time is 1us 10: filter time is 4us 11: The filtering time is 16us
3~2	-	Reserved

Preliminary

13.3 PWM0 Independent Mode

In independent mode (PWMMD.1 = 0), the duty cycle of 8 PWM channels can be set independently. The user configures the PWM output status and period, and then configures the duty cycle register of the corresponding PWM channel to output the PWM waveform at a fixed duty cycle.

13.3.1 PWM0 Independent Mode Block Diagram

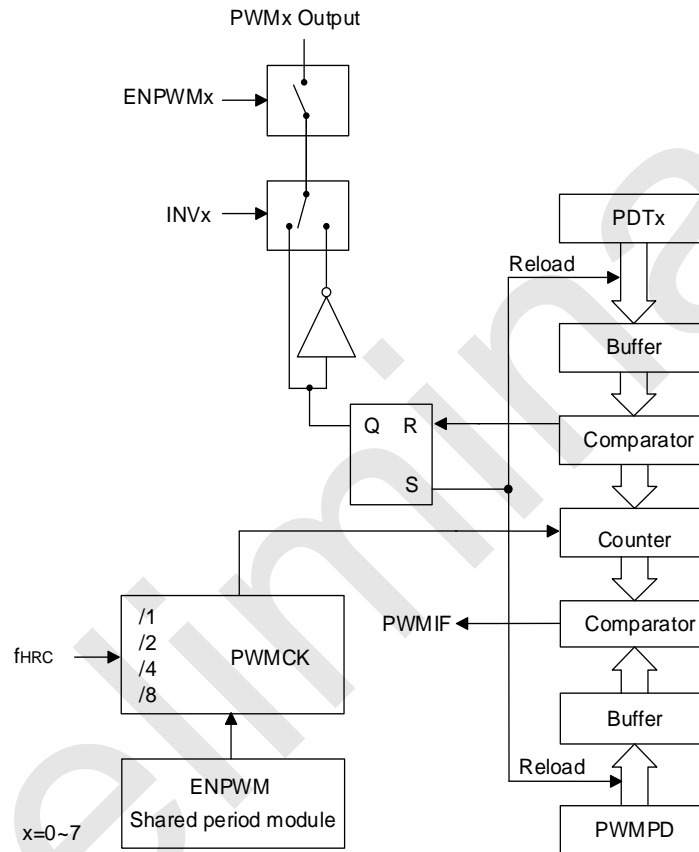

SC95F861XB PWM Independent mode block diagram

13.3.2 PWM0 Independent Mode Duty Cycle Configuration

PWM0 Duty Cycle Adjustment Register PDT0x (Read/Write)

2040H	PDT00[15:8]
2041H	PDT00[7:0]
2042H	PDT01[15:8]
2043H	PDT01[7:0]
2044H	PDT02[15:8]
2045H	PDT02[7:0]
2046H	PDT03[15:8]
2047H	PDT03[7:0]
2048H	PDT04[15:8]
2049H	PDT04[7:0]
204AH	PDT05[15:8]
204BH	PDT05[7:0]
204CH	PDT06[15:8]
204DH	PDT06[7:0]
204EH	PDT07[15:8]
204FH	PDT07[7:0]

Bit number	Bit Mnemonic	Description
7~0	PDT0x [15: 0] (x=0~7)	PWM0x waveform duty cycle length setting The high-level width of the PWM0x waveform is (PDT0x [15: 0]) PWM clocks

13.4 PWM0 Complementary Model

13.4.1 PWM0 Block Diagram of Complementary Mode

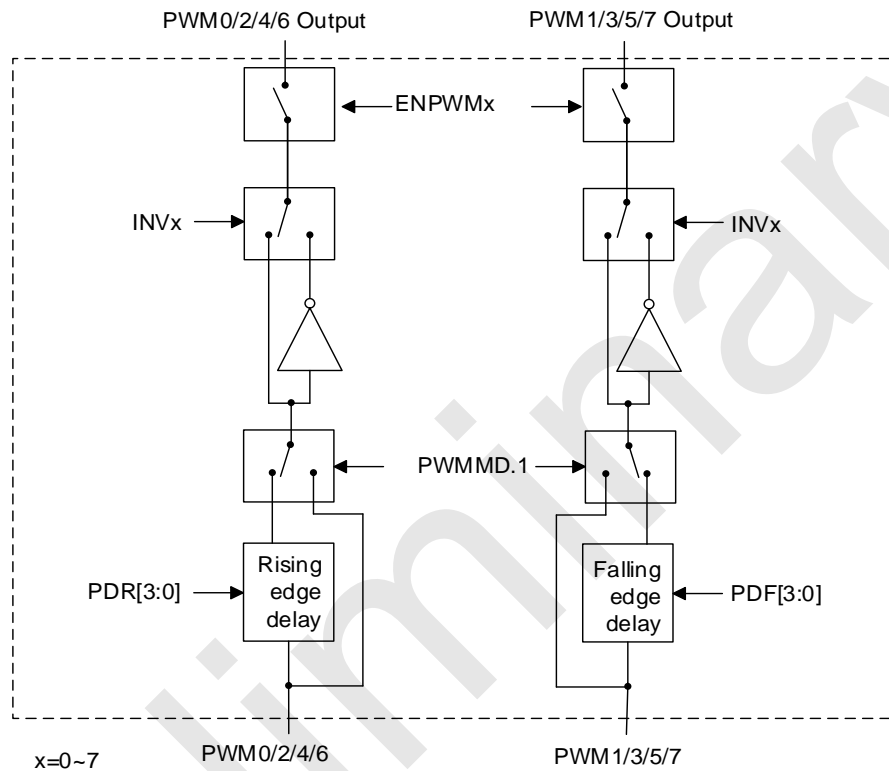

SC95F861XB PWM block diagram of complementary mode

13.4.2 PWM Complementary Mode Duty Cycle Configuration

In complementary mode ($PWMMD[1:0] = 1x$), PWM00/PWM01, PWM02/PWM03, PWM04/PWM05 and PWM06/PWM07 are divided into four groups, respectively through PTD00[15:0], PTD02[15:0], PTD04[15:0] and PTD06[15:0] adjust the duty ratio;

The registers PTD01[15:0], PTD03[15:0], PTD05 [15:0] and PTD07[15:0] are invalid in the complementary mode.

PWM0 Duty Cycle Adjustment Register PTD0x (Read/Write)

2040H	PTD00[15:8]
2041H	PTD00[7:0]

2042H	PDT01[15:8]
2043H	PDT01[7:0]
2044H	PDT02[15:8]
2045H	PDT02[7:0]
2046H	PDT03[15:8]
2047H	PDT03[7:0]
2048H	PDT04[15:8]
2049H	PDT04[7:0]
204AH	PDT05[15:8]
204BH	PDT05[7:0]
204CH	PDT06[15:8]
204DH	PDT06[7:0]
204EH	PDT07[15:8]
204FH	PDT07[7:0]

Bit number	Bit Mnemonic	Description
7~0	PDT0x [15: 0] (x=0~7)	PWM0x and PWM0y, y=x+1 port PWM waveform duty cycle length setting The high-level width of the PWM waveform on the Px and Py pins is (PDT0x [15: 0]) PWM clocks

Note:

1. If ENPWM is set to 1, the PWM module is turned on, but EMPWMx=0, the PWM output is turned off and used as a GPIO port. At this time, PWM module can be used as a 16-bit Timer. At this time, EPWM (IE1.1) is set to 1, and PWM will still generate an interrupt.

13.4.3 PWM Complementary Mode Dead Time Setting

When the PWM0 of the SC95F861XB works in complementary mode, the dead zone control module can prevent the effective time zones of the two PWM signals of complementary outputs from overlapping each other, so as to ensure that a pair of complementary power switch tubes driven by PWM signals will not be turned on at the same time.

PWMDFR (D6H) PWM0 Dead Time Setting Register (read/write)

Bit number	7	6	5	4	3	2	1	0
Bit Mnemonic	PDF[3: 0]				PDR[3: 0]			
R/W	R/W	R/W	R/W	R/W	R/W	R/W	R/W	R/W
POR	0	0	0	0	0	0	0	0

Bit number	Bit Mnemonic	Description
7~4	PDF[3: 0]	Complementary mode: PWM falling edge dead time= $4 \cdot \text{PDF}[3: 0] / f_{\text{HRC}}$
3~0	PDR[3: 0]	Complementary mode: PWM rising edge dead time= $4 \cdot \text{PDR}[3: 0] / f_{\text{HRC}}$

13.4.4 PWM0 Dead Zone Output Waveform

The following figure is based on the PWM00 and PWM01 in the complementary mode of the dead time adjustment waveform, in order to facilitate the distinction, PWM01 has reversed (INV1=1).

1. Dead zone not output:
 PWMPD.1 = X
 PDF = 0
 PDR = 0

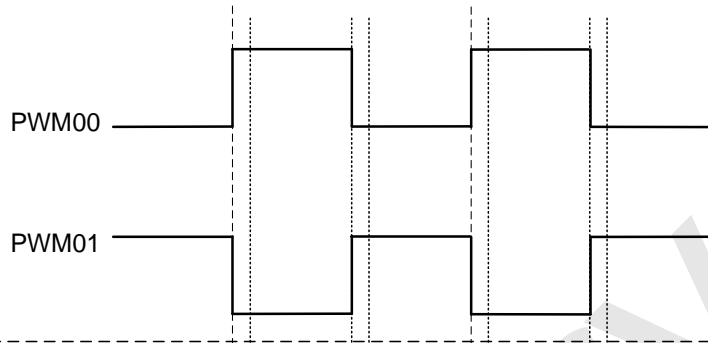

2. Setting PWM0 rising edge dead zone:
 PWMPD.1 = 1
 PDF = 0
 PDR = n

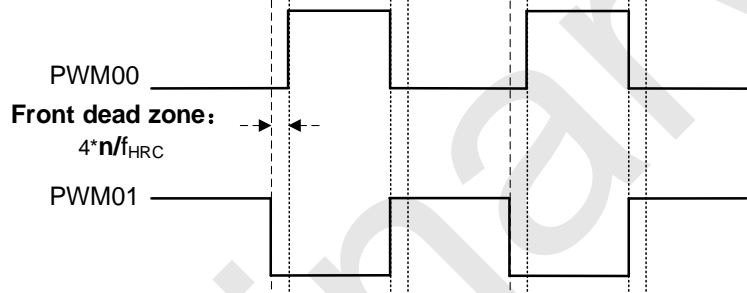

3. Setting PWM1 falling edge dead zone:
 PWMPD.1 = 1
 PDF = m
 PDR = n
 Note: PWM1 has reversed at this time, then PDF corresponds to control the Rising edge dead zone delay time of PWM1 output waveform

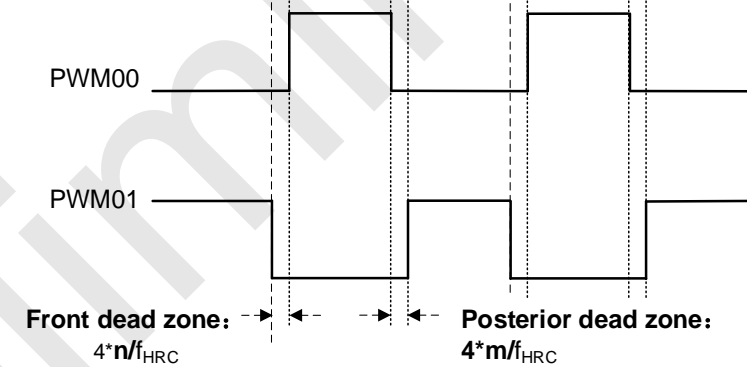

PWM0 dead zone output waveform

13.5 PWM0 Waveforms and Directions

The effect of changing SFR parameters on the PWM0 waveform is as follows:

① Duty cycle change characteristics

When the PWM0n outputs a waveform, if the duty cycle needs to be changed, it can be achieved by changing the value of the high-level setting register (PDT0x). But need to pay attention: change the value of PDT0x, the duty ratio will not change immediately, but wait for the PWM counter changing when it counts to 0 or up until it matches the value of the period setting item PWMPD[15:0] +1.

② Periodic change characteristics

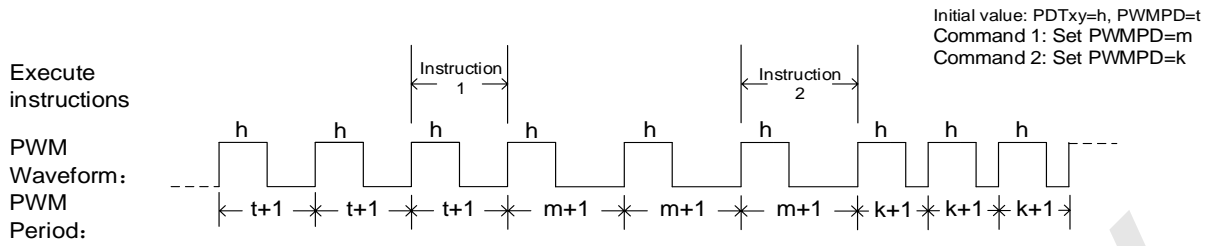

Periodic change characteristic diagram

When the PWM outputs a waveform, if the period needs to be changed, it can be achieved by changing the value of the period setting register PWMPD. Change the value of PWMPD, the cycle will not change immediately, but wait for the PWM counter changing when it counts to 0 or up until it matches the value of the period setting item PWMPD[15:0] + 1, refer to the figure above.

③ Relationship between period and duty cycle

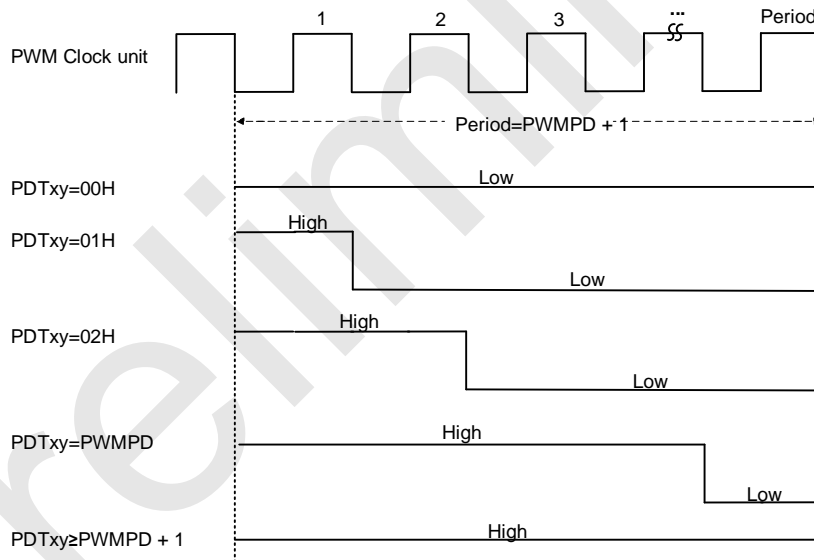

Relationship between cycle and duty cycle

The relationship between period and duty cycle is shown in the figure above. The premise of this result is that the PWM output inverse control (INVx, x=0~7) is initially 0. If you want to get the opposite result, you can set INVx to 1.

14 General-purpose I/O (GPIO)

The SC95F861XB provides up to 46 bidirectional GPIO ports that can be controlled. The input and output control registers are used to control the input and output status of each port. When the port is used as an input, each I/O port has an internal pull-up resistor controlled by PxPHy. The 46 IOs are multiplexed with other functions. Among them, P3 can be set to output 1/4VDD or 1/3VDD voltage, which can be used as a COM driver for LCD display. When the I/O port is in the input or output state, the actual state value of the port is read from the port data register.

Note: The unused and unleded IO ports should be set to strong push-pull output mode.

14.1 GPIO Structure Diagram

Strong Push-pull Output Mode

In the strong push-pull output mode, it can provide continuous high-current drive:

- Other than P04, P05, and P06, the I/O driver capability is an output greater than 10mA is high, and an output greater than 50mA is low.
- P04/P05/P06 drive can be achieved an output greater than 20mA is high, and an output greater than 50mA is low.

The schematic diagram of the port structure of the strong push-pull output mode is as follows:

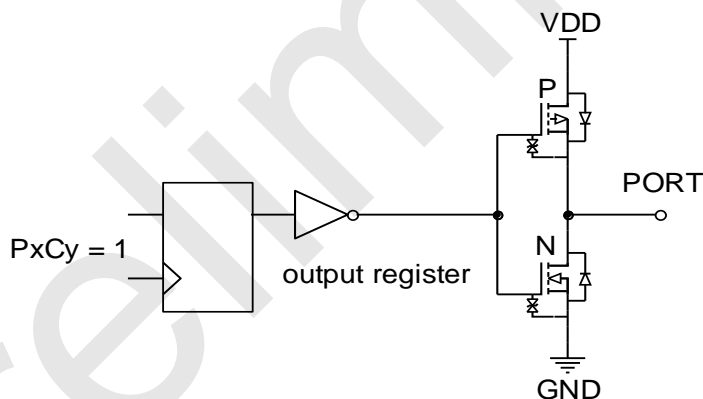

Strong push-pull output mode

Pull-up Input Mode

In the pull-up input mode, a pull-up resistor is constantly connected to the input port. Only when the input port is pulled low, the low-level signal is detected.

The schematic diagram of the port structure with pull-up input mode is as follows:

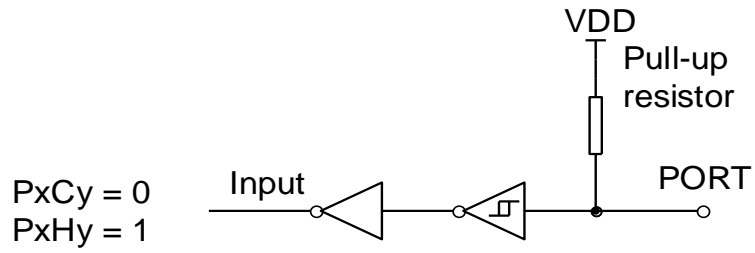

Input mode with pull-up resistor

High Impedance Input Mode (Input only)

The schematic diagram of the port structure of the high impedance input mode is as follows:

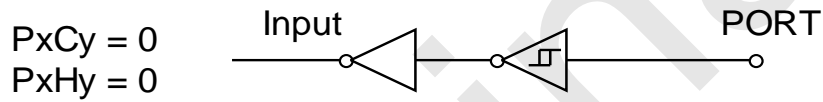

High impedance input mode

14.2 I/O Port-related Registers

P0CON (9AH) P0 Port Input/Output Control Register (read/write)

Bit number	7	6	5	4	3	2	1	0
Bit Mnemonic	P0C7	P0C6	P0C5	P0C4	P0C3	P0C2	P0C1	P0C0
R/W	R/W	R/W	R/W	R/W	R/W	R/W	R/W	R/W
POR	0	0	0	0	0	0	0	0

P0PH (9BH) P0 Port pull-up Resistor Control Register (read/write)

Bit number	7	6	5	4	3	2	1	0
Bit Mnemonic	P0H7	P0H6	P0H5	P0H4	P0H3	P0H2	P0H1	P0H0
R/W	R/W	R/W	R/W	R/W	R/W	R/W	R/W	R/W
POR	0	0	0	0	0	0	0	0

P1CON (91H) P1 Port Input/Output Control Register (read/write)

Bit number	7	6	5	4	3	2	1	0
Bit Mnemonic	P1C7	P1C6	P1C5	P1C4	P1C3	P1C2	P1C1	P1C0
R/W	R/W	R/W	R/W	R/W	R/W	R/W	R/W	R/W
POR	0	0	0	0	0	0	0	0

P1PH (92H) P1 Port Pull-up Resistor Control Register (read/write)

Bit number	7	6	5	4	3	2	1	0
Bit Mnemonic	P1H7	P1H6	P1H5	P1H4	P1H3	P1H2	P1H1	P1H0
R/W	R/W	R/W	R/W	R/W	R/W	R/W	R/W	R/W
POR	0	0	0	0	0	0	0	0

P2CON (A1H) P2 Port Input/output Control Register (read/write)

Bit number	7	6	5	4	3	2	1	0
Bit Mnemonic	P2C7	P2C6	P2C5	P2C4	P2C3	P2C2	P2C1	P2C0
R/W	R/W	R/W	R/W	R/W	R/W	R/W	R/W	R/W
POR	0	0	0	0	0	0	0	0

P2PH (A2H) P2 Port Pull-up Resistor Control Register (read/write)

Bit number	7	6	5	4	3	2	1	0
Bit Mnemonic	P2H7	P2H6	P2H5	P2H4	P2H3	P2H2	P2H1	P2H0
R/W	R/W	R/W	R/W	R/W	R/W	R/W	R/W	R/W
POR	0	0	0	0	0	0	0	0

P3CON (B1H) P3 Port Input/output Control Register (read/write)

Bit number	7	6	5	4	3	2	1	0
Bit Mnemonic	P3C7	P3C6	P3C5	P3C4	P3C3	P3C2	P3C1	P3C0
R/W	R/W	R/W	R/W	R/W	R/W	R/W	R/W	R/W
POR	0	0	0	0	0	0	0	0

P3PH (B2H) P3 Port Pull-up Resistor Control Register (read/write)

Bit number	7	6	5	4	3	2	1	0
Bit Mnemonic	P3H7	P3H6	P3H5	P3H4	P3H3	P3H2	P3H1	P3H0
R/W	R/W	R/W	R/W	R/W	R/W	R/W	R/W	R/W
POR	0	0	0	0	0	0	0	0

P4CON (C1H) P4 Port Input/output Control Register (read/write)

Bit number	7	6	5	4	3	2	1	0
Bit Mnemonic	P4C7	P4C6	P4C5	P4C4	P4C3	P4C2	P4C1	P4C0
R/W	R/W	R/W	R/W	R/W	R/W	R/W	R/W	R/W
POR	0	0	0	0	0	0	0	0

P4PH (C2H) P4 Port Pull-up Resistor Control Register (read/write)

Bit number	7	6	5	4	3	2	1	0
Bit Mnemonic	P4H7	P4H6	P4H5	P4H4	P4H3	P4H2	P4H1	P4H0
R/W	R/W	R/W	R/W	R/W	R/W	R/W	R/W	R/W
POR	0	0	0	0	0	0	0	0

P5CON (D9H) P5 Port Input/output Control Register (read/write)

Bit number	7	6	5	4	3	2	1	0
Bit Mnemonic	-	-	P5C5	P5C4	P5C3	P5C2	P5C1	P5C0
R/W	-	-	R/W	R/W	R/W	R/W	R/W	R/W
POR	x	x	0	0	0	0	0	0

P5PH (DAH) P5 Port Pull-up Resistor Control Register (read/write)

Bit number	7	6	5	4	3	2	1	0
Bit Mnemonic	-	-	P5H5	P5H4	P5H3	P5H2	P5H1	P5H0
R/W	-	-	R/W	R/W	R/W	R/W	R/W	R/W
POR	x	x	0	0	0	0	0	0

Bit number	Bit Mnemonic	Description
------------	--------------	-------------

7~0	PxCy (x=0~5, y=0~7)	Px port input and output control: 0: Pxy is the input mode (initial value at power-on) 1: Pxy is a strong push-pull output mode
7~0	PxHy (x=0~5, y=0~7)	The Px port pull-up resistor setting is only valid when PxCy=0: 0: Pxy is the high-impedance input mode (initial value at power-up), and the pull-up resistor is turned off; 1: Pxy pull-up resistor is on

P0 (80H) P0 Port Data Register (read/write)

Bit number	7	6	5	4	3	2	1	0
Bit Mnemonic	P0.7	P0.6	P0.5	P0.4	P0.3	P0.2	P0.1	P0.0
R/W	R/W	R/W	R/W	R/W	R/W	R/W	R/W	R/W
POR	0	0	0	0	0	0	0	0

P1 (90H) P1 Port Data Register (read/write)

Bit number	7	6	5	4	3	2	1	0
Bit Mnemonic	P1.7	P1.6	P1.5	P1.4	P1.3	P1.2	P1.1	P1.0
R/W	R/W	R/W	R/W	R/W	R/W	R/W	R/W	R/W
POR	0	0	0	0	0	0	0	0

P2 (A0H) P2 Port Data Register (read/write)

Bit number	7	6	5	4	3	2	1	0
Bit Mnemonic	P2.7	P2.6	P2.5	P2.4	P2.3	P2.2	P2.1	P2.0
R/W	R/W	R/W	R/W	R/W	R/W	R/W	R/W	R/W
POR	0	0	0	0	0	0	0	0

P3 (B0H) P3 Port Data Register (read/write)

Bit number	7	6	5	4	3	2	1	0
Bit Mnemonic	P3.7	P3.6	P3.5	P3.4	P3.3	P3.2	P3.1	P3.0
R/W	R/W	R/W	R/W	R/W	R/W	R/W	R/W	R/W
POR	0	0	0	0	0	0	0	0

P4 (C0H) P4 Port Data Register (read/write)

Bit number	7	6	5	4	3	2	1	0
Bit Mnemonic	P4.7	P4.6	P4.5	P4.4	P4.3	P4.2	P4.1	P4.0
R/W	R/W	R/W	R/W	R/W	R/W	R/W	R/W	R/W
POR	0	0	0	0	0	0	0	0

P5 (D8H) P5 Port Data Register (read/write)

Bit number	7	6	5	4	3	2	1	0
Bit Mnemonic	-	-	P5.5	P5.4	P5.3	P5.2	P5.1	P5.0
R/W	-	-	R/W	R/W	R/W	R/W	R/W	R/W
POR	x	x	0	0	0	0	0	0

Bit number	Bit Mnemonic	Description
7~0	P0.x (x=0~7)	P0 port latch register data
7~0	P1.x (x=0~7)	P1 port latch register data
7~0	P2.x (x=0~7)	P2 port latch register data
7~0	P3.x (x=0~7)	P3 port latch register data
7~0	P4.x (x=0~7)	P4 port latch register data
5~0	P5.x (x=0~5)	P5 port latch register data

IOHCON0 (96H) IOH Setting Register 0 (read/write)

Bit number	7	6	5	4	3	2	1	0
Bit Mnemonic	P1H[1: 0]		P1L[1: 0]		P0H[1: 0]		P0L[1: 0]	
R/W	R/W	R/W	R/W	R/W	R/W	R/W	R/W	R/W
POR	0	0	0	0	0	0	0	0

Bit number	Bit Mnemonic	Description
7~6	P1H[1: 0]	P1 high four IOH settings 00: Set P1 high four IOH level 0 (maximum); 01: Set P1 high four IOH level 1; 10: Set P1 high four IOH level 2; 11: Set P1 high four IOH level 3 (minimum);
5~4	P1L[1: 0]	P1 low four IOH settings 00: Set P1 low four IOH level 0 (maximum); 01: Set P1 low four IOH level 1; 10: Set P1 low four IOH level 2; 11: Set P1 low four IOH level 3 (minimum);
3~2	P0H[1: 0]	P0 high four IOH settings 00: Set P0 high four IOH level 0 (maximum); 01: Set P0 high four IOH level 1; 10: Set P0 high four IOH level 2; 11: Set P0 high four IOH level 3 (minimu
1~0	P0L[1: 0]	P0 low four IOH settings

		00: Set P0 low four IOH level 0 (maximum); 01: Set P0 low four IOH level 1; 10: Set P0 low four IOH level 2; 11: Set P0 low four IOH level 3 (minimum);
--	--	--

IOHCON1 (97H) IOH Setting Register 1 (read/write)

Bit number	7	6	5	4	3	2	1	0
Bit Mnemonic	-	-	P3L[1: 0]		P2H[1: 0]		P2L[1: 0]	
R/W	-	-	R/W	R/W	R/W	R/W	R/W	R/W
POR	x	x	0	0	0	0	0	0

Bit number	Bit Mnemonic	Description
5~4	P3L[1: 0]	P3 low four IOH settings 00: set P3 low four IOH level 0 (maximum); 01: Set P3 low four IOH level 1; 10: Set P3 low four IOH level 2; 11: Set P3 low four IOH level 3 (minimum);
3~2	P2H[1: 0]	P2 high four IOH settings 00: Set P2 high four IOH level 0 (maximum); 01: Set P2 high four IOH level 1; 10: Set P2 high four IOH level 2; 11: Set P2 high four IOH level 3 (minimum);

1~0	P2L[1: 0]	P2 low four IOH settings 00: Set P2 low four IOH level 0 (maximum); 01: Set P2 low four IOH level 1; 10: Set P2 low four IOH level 2; 11: Set P2 low four IOH level 3 (minimum);
7~6	-	Reserved

15 LCD/LED Display Driver

The SC95F861XB integrates hardware LCD/LED display drive circuit inside, which can facilitate users to realize LCD and LED display drive. Its main features are as follows:

1. Choose one of LCD and LED display driver;
2. LCD and LED display drivers share related IO ports and registers.

The LCD display driver functions are as follows:

1. 4 display drive modes are available: 8 X 24, 6 X 26, 5 X 27, or 4X 28 segments;
2. 2 kinds of offset methods are available: 1/4 Bias and 1/3 Bias;
3. 4 levels of COM port drive capability are optional;
4. The display drive circuit can choose the built-in 32 kHz LRC or external 32.768 kHz oscillator as the clock source, the frame frequency is about 64Hz.

Note: If the LCD driver frame frequency is not 64Hz, you are advised to contact sinone technical support for solutions.

The LED display driver functions are as follows:

1. 4 display drive modes are available: 8 X 24, 6 X 26, 5 X 27, or 4X 28 segments;
2. SEG port drive capability is optional in 4 levels;
3. The display drive circuit can select the built-in 32 kHz LRC or external 32.768kHz oscillator as the clock source, and the frame frequency is about 64Hz.

15.1 LCD/LED Display Drive-related Registers

DDRCON (93H) Display Drive Control Register (read/write)

Bit number	7	6	5	4	3	2	1	0
Bit Mnemonic	DDRON	DMOD	DUTY[1: 0]		VLCD[3: 0]			
R/W	R/W	R/W	R/W	R/W	R/W	R/W	R/W	R/W
POR	0	0	0	0	0	0	0	0

Bit number	Bit Mnemonic	Description
7	DDRON	LCD/LED display drive enable control 0: The display driver scan is turned off 1: The display driver scan is turned on
6	DMOD	LCD/LED display drive mode 0: LCD mode; 1: LED mode
5~4	DUTY[1: 0]	LCD/LED display duty control 00: 1/8 duty cycle, S4~S27 are segments, C0~C7 are common; 01: 1/6 duty cycle, S2~S27 are segments, C2~C7 are common; 10: 1/5 duty cycle, S1~S27 are segments, C3~C7 are common; 11: 1/4 duty cycle, S0~S27 is segment, C4~C7 is common, or S4~S27 is segment, C0~C3 is common
3~0	VLCD[3: 0]	LCD voltage regulation $VLCD = V_{DD} * (17 + VLCD[3: 0]) / 32$

P0VO (9CH) P0 Port Display Driver Output Register (read/write)

Bit number	7	6	5	4	3	2	1	0
Bit Mnemonic	P07VO	P06VO	P05VO	P04VO	P03VO	P02VO	P01VO	P00VO
R/W	R/W	R/W	R/W	R/W	R/W	R/W	R/W	R/W
POR	0	0	0	0	0	0	0	0

Bit number	Bit Mnemonic	Description
7~0	P0nVO	Open P0n port display driver output 0: Disable the display driver output function of P0n port 1: Enable the display driver output function of P0n port

P1VO (94H) P1 Port Display Driver Output Register (read/write)

Bit number	7	6	5	4	3	2	1	0
Bit Mnemonic	P17VO	P16VO	P15VO	P14VO	P13VO	P12VO	P11VO	P10VO
R/W	R/W	R/W	R/W	R/W	R/W	R/W	R/W	R/W
POR	0	0	0	0	0	0	0	0

Bit number	Bit Mnemonic	Description
7~0	P1nVO	Open P1n port display driver output 0: Disable the display driver output function of P1n port 1: Enable the display driver output function of P1n port

P2VO (A3H) P2 Port Display Driver Output Register (read/write)

Bit number	7	6	5	4	3	2	1	0
Bit Mnemonic	P27VO	P26VO	P25VO	P24VO	P23VO	P22VO	P21VO	P20VO
R/W	R/W	R/W	R/W	R/W	R/W	R/W	R/W	R/W

POR	0	0	0	0	0	0	0	0
-----	---	---	---	---	---	---	---	---

Bit number	Bit Mnemonic	Description
7~0	P2nVO	Open P2n port display driver output 0: Disable the display driver output function of P2n port 1: Enable the display driver output function of P2n port

P3VO (B3H) P3 Port Display Driver Output Register (read/write)

Bit number	7	6	5	4	3	2	1	0
Bit Mnemonic	P37VO	P36VO	P35VO	P34VO	P33VO	P32VO	P31VO	P30VO
R/W	R/W	R/W	R/W	R/W	R/W	R/W	R/W	R/W
POR	0	0	0	0	0	0	0	0

Bit number	Bit Mnemonic	Description
7~0	P3nVO	Open P3n port display driver output 0: Disable the display driver output function of P3n port 1: Enable the display driver output function of the P3n port

OTCON (8FH) Output Control Register (read/write)

Bit number	7	6	5	4	3	2	1	0
------------	---	---	---	---	---	---	---	---

Bit Mnemonic	USMD1[1: 0]		USMD0[1: 0]		VOIRS[1: 0]		SCS	BIAS
R/W	R/W	R/W	R/W	R/W	R/W	R/W	R/W	R/W
POR	0	0	0	0	0	0	0	0

Bit number	Bit Mnemonic	Description
3~2	VOIRS[1: 0]	<p>LCD voltage output port voltage divider resistance selection</p> <p>00: Set the total resistance of the internal voltage divider to be 100kΩ</p> <p>01: Set the total resistance of the internal voltage divider resistor to 200kΩ</p> <p>10: Set the total resistance of the internal voltage divider to 400kΩ</p> <p>11: Set the total resistance of the internal voltage divider to 800kΩ</p> <p>Each time Common is switched, the first 1/16 time is fixed to select a 100k resistor, and the last 15/16 time is switched to the resistance value selected by VORIS</p>
1	SCS	<p>LCD/LED Segment/Common multiplex pin selection</p> <p>0: When set to 1/4 duty cycle, S0~S27 are segments and C4~C7 are common</p> <p>1: When set to 1/4 duty cycle, S4~S27 are segments and C0~C3 are common</p>
0	BIAS	<p>LCD display drive bias voltage setting:</p> <p>0: 1/4 bias voltage;</p> <p>1: 1/3 bias voltage</p>

15.2 LCD/LED Display RAM Configuration

Address	7	6	5	4	3	2	1	0
---------	---	---	---	---	---	---	---	---

	COM7	COM6	COM5	COM4	COM3	COM2	COM1	COM0
2000H	SEG0	SEG0	SEG0	SEG0	SEG0	SEG0	SEG0	SEG0
2001H	SEG1	SEG1	SEG1	SEG1	SEG1	SEG1	SEG1	SEG1
2002H	SEG2	SEG2	SEG2	SEG2	SEG2	SEG2	SEG2	SEG2
2003H	SEG3	SEG3	SEG3	SEG3	SEG3	SEG3	SEG3	SEG3
2004H	SEG4	SEG4	SEG4	SEG4	SEG4	SEG4	SEG4	SEG4
2005H	SEG5	SEG5	SEG5	SEG5	SEG5	SEG5	SEG5	SEG5
2006H	SEG6	SEG6	SEG6	SEG6	SEG6	SEG6	SEG6	SEG6
2007H	SEG7	SEG7	SEG7	SEG7	SEG7	SEG7	SEG7	SEG7
2008H	SEG8	SEG8	SEG8	SEG8	SEG8	SEG8	SEG8	SEG8
2009H	SEG9	SEG9	SEG9	SEG9	SEG9	SEG9	SEG9	SEG9
200AH	SEG10	SEG10	SEG10	SEG10	SEG10	SEG10	SEG10	SEG10
200BH	SEG11	SEG11	SEG11	SEG11	SEG11	SEG11	SEG11	SEG11
200CH	SEG12	SEG12	SEG12	SEG12	SEG12	SEG12	SEG12	SEG12
200DH	SEG13	SEG13	SEG13	SEG13	SEG13	SEG13	SEG13	SEG13
200EH	SEG14	SEG14	SEG14	SEG14	SEG14	SEG14	SEG14	SEG14
200FH	SEG15	SEG15	SEG15	SEG15	SEG15	SEG15	SEG15	SEG15
2010H	SEG16	SEG16	SEG16	SEG16	SEG16	SEG16	SEG16	SEG16

2011H	SEG17	SEG17	SEG17	SEG17	SEG17	SEG17	SEG17	SEG17
2012H	SEG18	SEG18	SEG18	SEG18	SEG18	SEG18	SEG18	SEG18
2013H	SEG19	SEG19	SEG19	SEG19	SEG19	SEG19	SEG19	SEG19
2014H	SEG20	SEG20	SEG20	SEG20	SEG20	SEG20	SEG20	SEG20
2015H	SEG21	SEG21	SEG21	SEG21	SEG21	SEG21	SEG21	SEG21
2016H	SEG22	SEG22	SEG22	SEG22	SEG22	SEG22	SEG22	SEG22
2017H	SEG23	SEG23	SEG23	SEG23	SEG23	SEG23	SEG23	SEG23
2018H	SEG24	SEG24	SEG24	SEG24	SEG24	SEG24	SEG24	SEG24
2019H	SEG25	SEG25	SEG25	SEG25	SEG25	SEG25	SEG25	SEG25
201AH	SEG26	SEG26	SEG26	SEG26	SEG26	SEG26	SEG26	SEG26
201BH	SEG27	SEG27	SEG27	SEG27	SEG27	SEG27	SEG27	SEG27

15.3 LCD Waveform

15.3.1 1/3Bias LCD Waveform

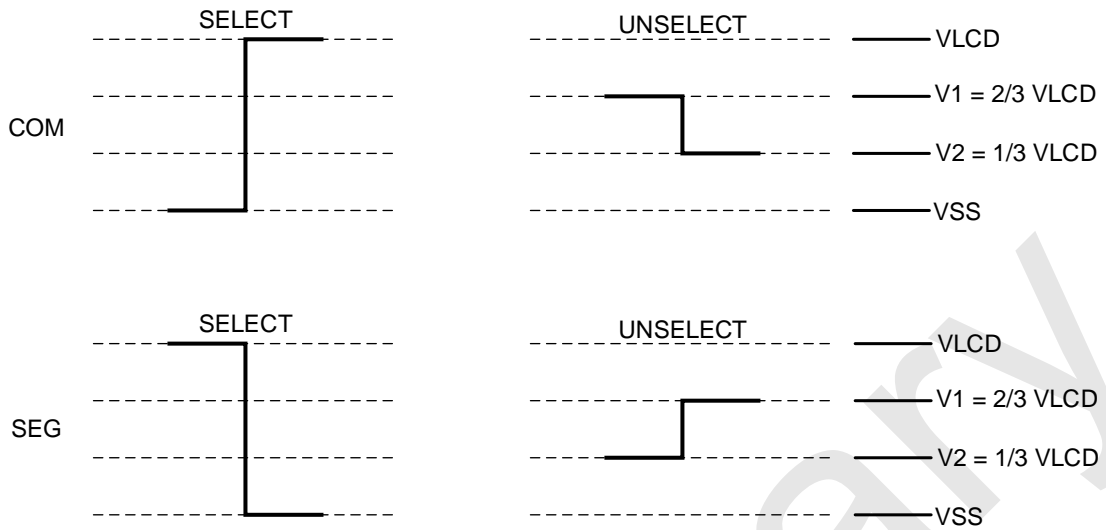

1/3 Bias LCD Gated and non-gated voltages

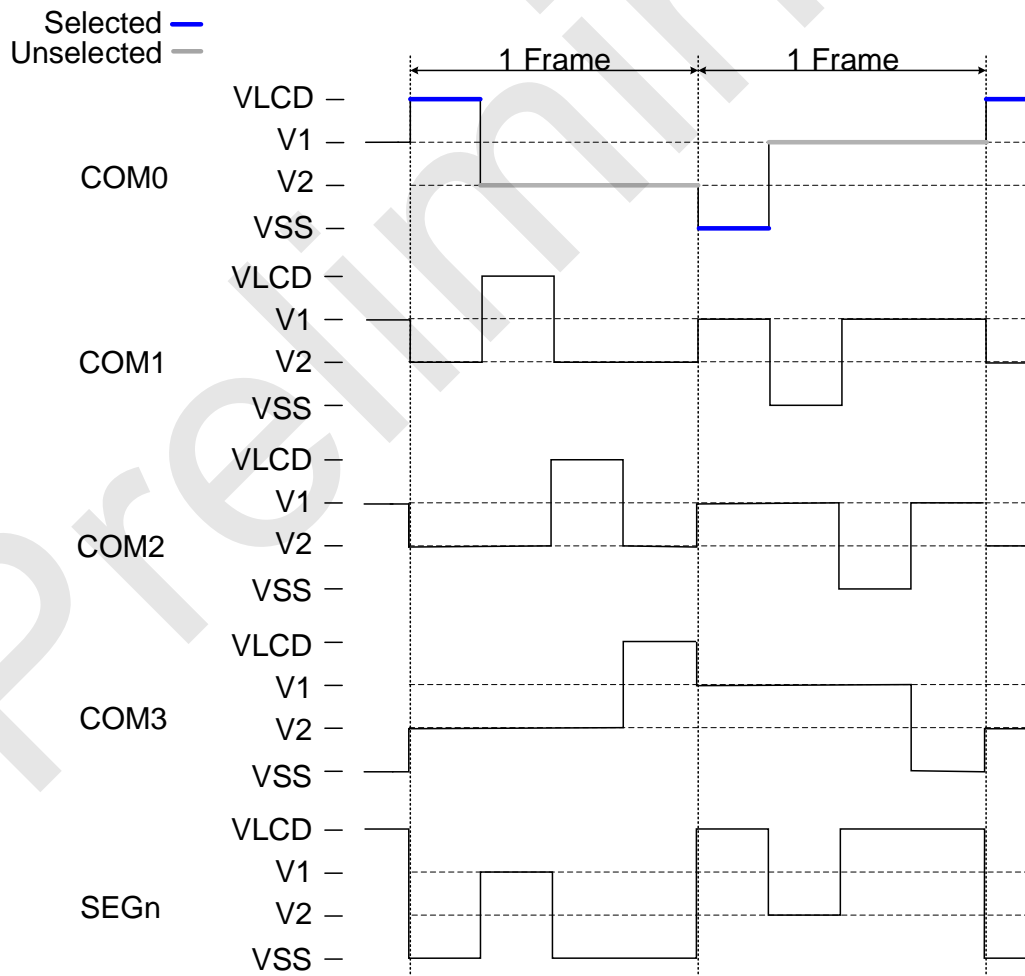

1/3 Bias Waveforms of COM and SEG in LCD applications

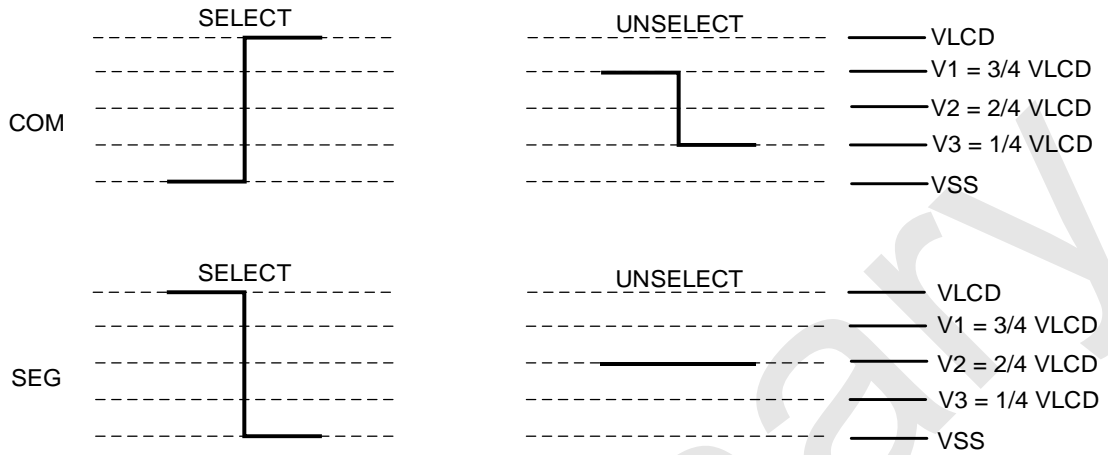
15.3.2 1/4Bias LCD Waveform

1/4 Bias LCD Gated and non-gated voltages

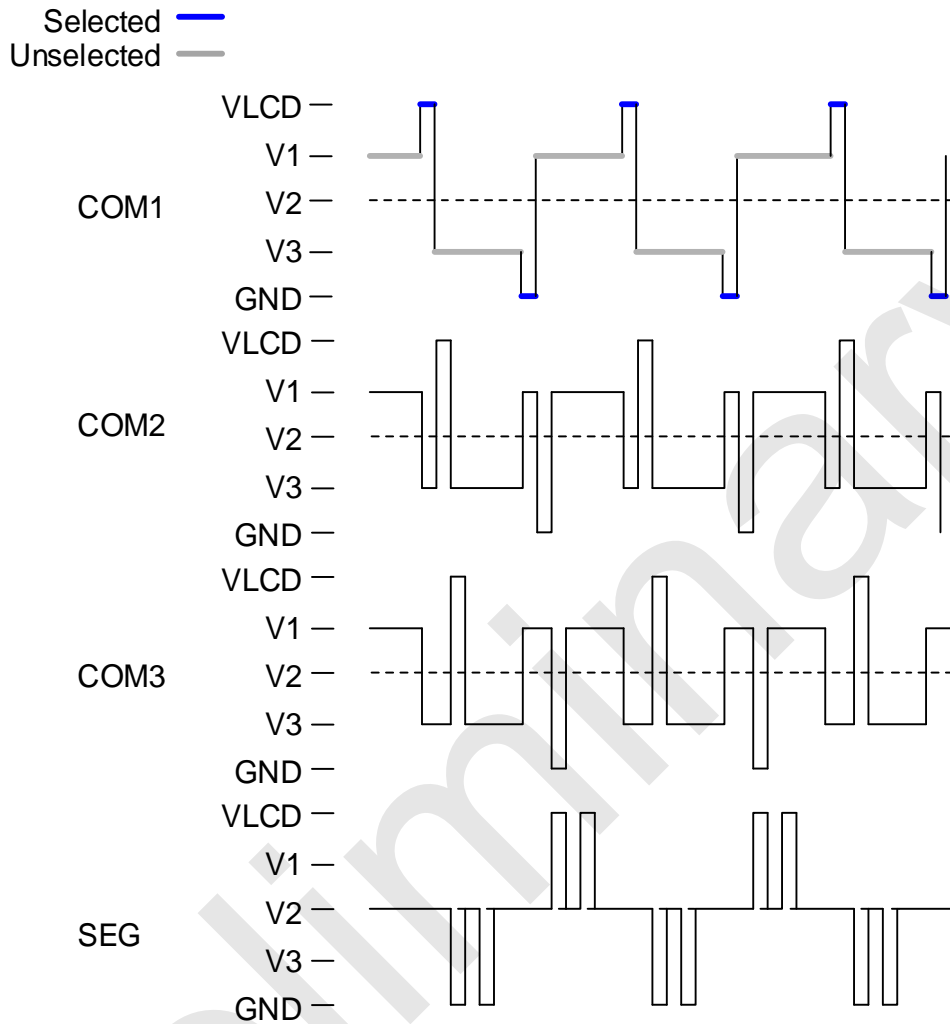

1/4 Bias Waveforms of COM and SEG in LCD applications

15.4 LED Waveform

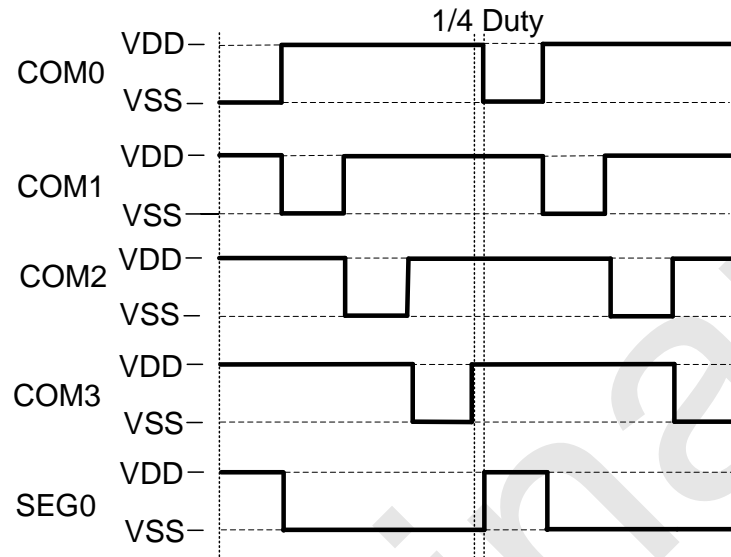

Waveforms of COM and SEG in LED applications

15.5 LCD/LED Example

15.5.1 LCD Configuration Demo Program

```

unsigned char xdata LCDRAM[30] _at_ 0x2000;

unsigned char lcd_addr;

unsigned char lcd_data;

DDRCON |= 0x00;    //0: LCD mode 1: LED mode

DDRCON |= 0x30;    //1/4 Duty cycle

DDRCON |= 0x07;    // VLCD=VDD*3/4

DDRCON |= 0x80;    // Display driver scan on

P0VO = 0xFF;      // Open the display driver output function of P0 port

P1VO = 0xFF;      // Open the display driver output function of P1 port

P2VO = 0xFF;      // Open the display driver output function of P2 port

```

```
P3VO = 0xFF;           // Open the display driver output function of P3 port

OTCON = 0x06; // Set the total resistance of the internal voltage divider resistor to 200KΩ

                //1/4 Bias voltage; S4~S27 is segment,C0~C3 is common

LCDRAM[lcd_addr] = lcd_data; //Write the value to be displayed to the LCD RAM
```

15.5.2 LED Configuration Demo Program

```
unsigned char xdata LEDRAM[30] _at_ 0x2000;

unsigned char led_addr;

unsigned char led_data;

DDRCON |= 0x4F;       //0: LCD mode1 : LED mode

                    //LED mode; 1/8 Duty cycle

                    //S4~S27 is segment,C0~C7 is common;

DDRCON |= 0x80;       // Display driver scan on

IOHCON0 = 0xC0;       // Set P1 high four IOH level 3 (minimum), other pins IOH level 0

                    (maximum)

IOHCON1 = 0x00;

P0VO = 0xFF;         // Open the display driver output function of P0 port

P1VO = 0xFF;         // Open the display driver output function of P1 port

P2VO = 0xFF;         // Open the display driver output function of P2 port

P3VO = 0xFF;         // Open the display driver output function of P3 port

OTCON = 0x00;

LCDRAM[led_addr] = led_data; //Write the value to be displayed to the LED RAM
```

16 SERIAL INTERFACE (UART0)

The SC95F861XB supports a full-duplex serial port, which can be conveniently used for connection with other devices or equipment, such as Wifi module circuit or other UART communication interface driver chip. The functions and features of UART0 are as follows:

1. Three communication modes are available: Mode 0, Mode 1 and Mode 3;
2. Can choose Timer 1 or Timer 2 as the baud rate generator;
3. Interrupt RI/TI can be generated after transmission and reception are completed, and the interrupt flag needs to be cleared by software.

SCON (98H) Serial Control Register (read/write)

Bit number	7	6	5	4	3	2	1	0
Bit Mnemonic	SM0	SM1	SM2	REN	TB8	RB8	TI	RI
R/W	R/W	R/W	R/W	R/W	R/W	R/W	R/W	R/W
POR	0	0	0	0	0	0	0	0

Bit number	Bit Mnemonic	Description
7~6	SM0~1	Serial communication mode control bit 00: Mode 0, 8-bit half-duplex synchronous communication mode, serial data is sent and received on the RX pin. The TX pin is used as the transmit shift clock. 8 bits are sent and received per frame, the low bit is received or sent first; 01: Mode 1, 10-bit full-duplex asynchronous communication, consisting of 1 start bit, 8 data bits and 1 stop bit, the communication baud rate is variable; 10: reserved; 11: Mode 3, 11-bit full-duplex asynchronous communication, consisting of 1 start bit, 8 data bits, a programmable 9th bit, and 1 stop bit. The communication baud rate is variable.
5	SM2	Serial communication mode control bit 2, this control bit is only valid for mode 3

		<p>0: set RI to generate an interrupt request every time a complete data frame is received;</p> <p>1: When a complete data frame is received, RI will be set to generate an interrupt request only when RB8=1.</p> <p>The baud rate override setting bit is only valid in mode 0 (SM0~1 = 00):</p> <p>0: The serial port runs at 1/12 of the system clock</p> <p>1: The serial port runs at 1/4 of the system clock</p>
4	REN	<p>Receive enable control bit</p> <p>0: data reception is not allowed;</p> <p>1: Allow receiving data.</p>
3	TB8	Only valid for mode 3, which is the 9th bit of the transmitted data
2	RB8	Only valid for mode 3, the 9th bit of the received data
1	TI	Transmit interrupt flag
0	RI	Receive interrupt flag

SBUF (99H) Serial Data Buffer Register (read/write)

Bit number	7	6	5	4	3	2	1	0
Bit Mnemonic	SBUF[7: 0]							
R/W	R/W	R/W	R/W	R/W	R/W	R/W	R/W	R/W
POR	0	0	0	0	0	0	0	0

Bit number	Bit Mnemonic	Description
------------	--------------	-------------

7~0	SBUF[7: 0]	Serial data buffer register SBUF contains two registers: a transmit shift register and a receive latch. The data written to SBUF will be sent to the transmit shift register and start the transmission process. Reading SBUF will return the contents of the receive latch.
-----	-------------------	--

PCON (87h) Power Management Control Register (write only, *unreadable*)

Bit number	7	6	5	4	3	2	1	0
Bit Mnemonic	SMOD	-	-	-	RST	-	STOP	IDL
R/W	-\write only	-	-	-	Write only	-	Write only	Write only
POR	0	x	x	x	n	x	0	0

Bit number	Bit Mnemonic	Description
7~0	SBUF[7: 0]	When SM0~1 = 01 (UART0 mode 1) or SM0~1 = 11 (UART0 mode 3), the baud rate is set to bit: 0: the serial port runs at 1/fsys 1: indicates that the serial port runs at 16/fsys

16.1 Baud Rate of Serial Communication

In mode 0, the baud rate can be programmed to 1/12 or 1/4 of the system clock:

1. SM2=0, the serial port runs at 1/12 of the system clock;
 2. SM2=1, the serial port runs at 1/4 of the system clock.
- In modes 1 and 3, the serial port clock source can be programmed as either 1 or 16 of the system clock, determined by SMOD(pcon.7) bits. When SMOD is 0, the serial port runs at 1/fsys. When SMOD is 1, the serial port runs at 16/fsys. After the serial port clock source is determined, set the baud rate overflow rate by Timer 1 or Timer 2: When TCLK(TXCON. 4) and RCLK(TXCON. 5) bits are both 0, then timer 1 is baud rate generator mode, and the baud rate overflow rate of UART0 is set by [TH1,TL1]. The formula is as follows, note: When timer 1 acts as a baud rate generator, timer 1 must stop counting, i.e. TR1=0:
 - SMOD = 0: $BaudRate = fsys / ([TH1, TL1]);$ (Note: [TH1, TL1] must be bigger than 0x0010)
 - SMOD = 1: $BaudRate = 1/16 * fsys / ([TH1, TL1]);$

- When TCLK(TXCON. 4) or RCLK(TXCON. 5) is 1, then timer 2 is in baud rate generator mode, and the baud rate overflow rate of UART0 is set by [RCAP2H, RCAP2L], the formula is as follows:
 - SMOD = 0: $\text{BaudRate} = \text{fsys} / [\text{RCAP2H}, \text{RCAP2L}]$; Note: [RCAPXH, RCAPXL] must be bigger than 0x0010)
 - SMOD = 1: $\text{BaudRate} = 1/16 * \text{fsys} / [\text{RCAP2H}, \text{RCAP2L}]$;

Preliminary

17 SPI/TWI/UART Serial Interface (USCI)

Symbol	Address	Description	7	6	5	4	3	2	1	0	POR
US0CON0	95H	USCI0 control register 0	US0CON0[7: 0]								0000000 0b
US0CON1	9DH	USCI0 control register 1	US0CON1[7: 0]								0000000 0b
US0CON2	9EH	USCI0 control register 2	US0CON2[7: 0]								0000000 0b
US0CON3	9FH	USCI0 control register 3	US0CON3[7: 0]								0000000 0b
US1CON0	A4H	USCI1 control register 0	US1CON0[7: 0]								0000000 0b
US1CON1	A5H	USCI1 control register 1	US1CON1[7: 0]								0000000 0b
US1CON2	A6H	USCI1 control register 2	US1CON2[7: 0]								0000000 0b
US1CON3	A7H	USCI1 control register 3	US1CON3[7: 0]								0000000 0b
USXCON0	C4H	USCI2 control register 0	US2CON0[7: 0]								0000000 0b
USXCON1	C5H	USCI2 control register 1	US2CON1[7: 0]								0000000 0b
USXCON2	C6H	USCI2 control register 2	US2CON2[7: 0]								0000000 0b
USXCON3	C7H	USCI2 control register 3	US2CON3[7: 0]								0000000 0b

USXINX	DCH	USCI2/3/4/5 Control register pointer	-	-	-	-	-	USCIX[2:0]		xxxxx000b	
TMCON	8EH	Timer frequency control register	USMDX[1:0]		-	-	-	-	T1FD	T0FD	00xxxx00b
OTCON	8FH	Output control register	USMD1[1:0]	USMD0[1:0]		VOIRS[1:0]		SCS	BIAS	00000000b	

The SC95F861XB internally integrates 6 three-select one universal serial circuits interface (referred to as USCI), which can facilitate the connection between MCU and devices or equipment with different interfaces. The user can configure the USCIO~5 interface to any one of SPI, TWI and UART through the USMD1[1: 0], USMD0[1: 0] bits of the configuration register OTCON, or the USMDX[1: 0] bits of TMCON. Its characteristics are as follows:

1. When USCIO is set to SPI0, the output drive capability is enhanced, which is consistent with common I/O features in other modes
2. SPI mode can be configured as one of master mode or slave mode, with 8-bit or 16-bit transmission mode
3. TWI mode communication can be configured as master mode or slave mode
4. UART modes can work in: Mode 0: 8-bit half-duplex synchronous communication, Mode 1: 10-bit full-duplex asynchronous communication and Mode 3: 11-bit full-duplex asynchronous communication
5. USCIO1/2/3/4 are independent USCI interfaces. Note the following: The USCIO2/3/4/5 control registers share the same set of addresses (C4H-C7H). Users can point the USCIX register group (USXCON0~3) to USCIO2/3/4/5 through USXINX[2:0], thus realizing the function of configuring three independent USCI interfaces for one set of registers

Note: Only after USXINX[2:0] has been successfully configured will the USCIX register group point to USCIO2/3/4/5 specified by the user, in which case set the USCIX register group is valid for the corresponding USCI interface.

The specific configuration method is as follows:

USXINX (DCH) USCIO2/3/4/5 Control register pointer (R/W)

Bit number	7	6	5	4	3	2	1	0
Bit Mnemonic	-	-	-	-	-	USCIX[2:0]		
R/W	-	-	-	-	-	R/W	R/W	R/W
POR	x	x	x	x	x	0	1	0

Bit number	Bit Mnemonic	Description
------------	--------------	-------------

2~0	USCIX[2:0]	USCIX2/3/4/5 Control register pointer 010: USCIX register (USXCON0~3 及 USMDX) point to USCIX2 011: USCIX register point to USCIX3 100: USCIX register point to USCIX4 101: USCIX register point to USCIX5 Other:Reserved
5~3	-	Reserved

OTCON (8FH) Output Control Register (read/write)

Bit number	7	6	5	4	3	2	1	0
Bit Mnemonic	USMD1[1: 0]		USMD0[1: 0]		VOIRS[1: 0]		SCS	BIAS
R/W	R/W	R/W	R/W	R/W	R/W	R/W	R/W	R/W
POR	0	0	0	0	0	0	0	0

Bit number	Bit Mnemonic	Description
7~6	USMD1[1: 0]	USCIX1 Communication mode control bit 00: USCIX1 close 01: USCIX1 Set to SPI communication mode; 10: USCIX1 Set to TWI communication mode; 11: USCIX1 Set to UART communication mode;
5~4	USMD0[1: 0]	USCIX0 Communication mode control bit 00: Reserved; 01: USCIX0 Set to SPI communication mode; 10: USCIX0 Set to TWI communication mode;

		11: USC10 Set to UART communication mode;
--	--	---

TMCON (8EH) Timer Frequency Control Register (read/write)

Bit number	7	6	5	4	3	2	1	0
Bit Mnemonic	USMDX[1: 0]		-	-	-	-	T1FD	T0FD
R/W	R/W	R/W	-	-	-	-	R/W	R/W
POR	0	0	x	x	x	x	0	0

Bit number	Bit Mnemonic	Condition	Description
7~6	USMDX[1: 0]	USCIX = 010	USC12 Communication mode control bit 00: USC12 close 01: USC12 set to SPI communication mode; 10: USC12 set to TWI communication mode; 11: USC12 set to UART communication mode;
		USCIX = 011	USC13 Communication mode control bit 00: USC13 close 01: USC13 set to SPI communication mode; 10: USC13 set to TWI communication mode; 11: USC13 set to UART communication mode;
		USCIX = 100	USC14 Communication mode control bit 00: USC14 close 01: USC14 set to SPI communication mode;

			10: USCI4 set to TWI communication mode; 11: USCI4 set to UART communication mode;
		USCIX = 101	USCI5 Communication mode control bit 00: USCI5 close 01: USCI5 set to SPI communication mode; 10: USCI5 set to TWI communication mode; 11: USCI5 set to UART communication mode;

Note:

A USCI interface can be set to different communication modes by USMD, each of which has a corresponding operation register group. The control register groups in different communication modes share the same mapped address, but the operations among the groups are independent. Setting the control register in one communication mode does not affect the values in the register groups in other communication modes.

For example:

- Set USMD1 = 01, USCI0 is SPI communication interface, in this mode set US0CON0 (95H) = 0x80H;
- Then set USMD1 = 11, USCI0 is the UART communication interface, set US0CON0 (95H) = 0x0FH;
- Then set USMD1 = 01, USCI0 is set back to SPI communication interface, read US0CON0 (95H) in this mode, should be 0x80H;
- Then set USMD1 = 11, USCI0 is set back to the UART communication interface, and US0CON0 (95H) is read in this mode, which should be 0x0FH.

17.1 SPI

USMDn[1: 0] = 01, n=0~5, select one of three serial interface USCI is configured as SPI interface:

- USTXn as MOSI signal
- USRXn as MISO signal
- USCKn as CLK signal

Serial Peripheral Device Interface (SPI for short) is a high-speed serial communication interface that allows the MCU to perform full-duplex, synchronous serial communication with peripheral devices (including other MCUs).

The SPI interface of USCI0 has 16-bit 8-level FIFO cache and is independent of sending and receiving, that is, users can achieve:

- Write up to 8 bits or less 16-bit data sequentially to SPI send caches (US0CON2, US0CON3). When the SPI sends data, the first data written is also sent first. When the data written into the FIFO by the user is sent, the null flag TXE of the sending buffer is set to 1. If the DATA in THE FIFO is full, the write conflict flag bit WCOL is set, and the user cannot write data to the FIFO until the data in the FIFO is sent out and the FIFO is not satisfied. The interrupt flag SPIF is raised when all data in the FIFO is sent.

- The SPI receive cache (US0CON2, US0CON3) continuously reads 8 or less 16-bit received data, and the first received data is also read first.
- In addition, when USC10 is set as SPI0, the driving ability of the pins corresponding to its signal port will be enhanced.

Contrast BIT	USC11~5 SPI	USC10 SPI
TXE	The send buffer is empty, set 1	Set to 1 when data written to the FIFO is sent
WCOL	When a frame is being sent, rewrites are set to 1 and cannot write	If the FIFO is filled, set it to 1, and can't write the FIFO
SPIF	Send complete, interrupt flag set up	The interrupt flag is not raised until all data in the FIFO is sent

17.1.1 SPI Operation Related Registers

US0CON0 (95H) SPI0 control register (read/write)

US1CON0 (A4H) SPI1 control register (read/write)

USXCON0 (C4H) SPI2~5 control register (read/write)

Bit number	7	6	5	4	3	2	1	0
Bit Mnemonic	SPEN	-	MSTR	CPOL	CPHA	SPR2	SPR1	SPR0
R/W	R/W	-	R/W	R/W	R/W	R/W	R/W	R/W
POR	0	x	0	0	0	0	0	0

Bit number	Bit Mnemonic	Description
7	SPEN	SPI Enable control 0: close SPI

		1: open SPI
5	MSTR	SPI master-slave selection 0: SPI is slave device 1: SPI is master device
4	CPOL	Clock polarity control bit 0: SCK is low in idle state 1: SCK is high in idle state
3	CPHA	Clock phase control bit 0: Collect data on the first edge of the SCK cycle 1: Collect data on the second edge of the SCK cycle
2~0	SPR[2: 0]	SPI Clock rate selection bit 000: fsys 001: fsys/2 010: fsys/4 011: fsys/8 100: fsys/16 101: fsys/32 110: fsys/64 111: fsys/128
1	-	Reserved

US0CON1 (9DH) SPI0 Status Register (read/write)

US1CON1 (A5H) SPI1 Status Register (read/write)

USXCON1 (C5H) SPI2~5 Status Register (read/write)

Bit number	7	6	5	4	3	2	1	0
Bit Mnemonic	SPIF	WCOL	-	-	TXE	DORD	SPMD	TBIE
R/W	R/W	R/W	-	-	R/W	R/W	R/W	R/W
POR	0	0	x	x	0	0	0	0

Bit number	Bit Mnemonic	Description
7	SPIF	SPI data transmission flag 0: Cleared by software 1: Indicates that data transmission has been completed, set by hardware
6	WCOL	Write conflict flag 0: Cleared by software, indicating that the write conflict has been processed 1: Set by hardware to indicate that a conflict is detected Transmission direction selection bit
3	TXE	Send cache null flag 0: The send cache is not empty 1: The send cache is empty and must be cleared by the software. At this time, the user can write data to FIFO.
2	DORD	Transmission direction selection bit 0: MSB first sent

		1: LSB first sent
1	SPMD	SPI transmission mode selection: 0: 8-bit mode 1: 16-bit mode
	TBIE	Interrupt enable bit when the send cache is empty: 0: When TXE=1, interrupts are not allowed 1: When TXE=1, SPI interrupt is generated
5~4	-	Reserved

US0CON2 (9EH) SPI0 Data register low byte (read/write)

US1CON2 (A6H) SPI1 Data register low byte (read/write)

USXCON2 (C6H) SPI2~5 Data register low byte (read/write)

Bit number	7	6	5	4	3	2	1	0
Bit Mnemonic	SPDL[7: 0]							
R/W	R/W	R/W	R/W	R/W	R/W	R/W	R/W	R/W
POR	0	0	0	0	0	0	0	0

Bit number	Bit Mnemonic	Description
7~0	SPDL[7: 0]	SPI data buffer register low byte (8/16 bit mode) Low byte of data written to data register SPD Read data low byte of data register SPD

US0CON3 (9FH) SPI0 Data register high byte (read/write)

US1CON3 (A7H) SPI1 Data register high byte (read/write)

USXCON3 (C7H) SPI2~5 Data register high byte (read/write)

Bit number	7	6	5	4	3	2	1	0
Bit Mnemonic	SPDH[7: 0]							
R/W	R/W	R/W	R/W	R/W	R/W	R/W	R/W	R/W
POR	0	0	0	0	0	0	0	0

Bit number	Bit Mnemonic	Description
7~0	SPDH[7: 0]	SPI data buffer register high byte (only for 16-bit mode) High byte of data written to data register SPD Read data high byte of data register SPD Note: When SPI is set to 16-bit mode, you must write the high byte first, then write the low byte, and start sending immediately after the low byte is written

17.1.2 Signal Description

Master-Out/Slave-In (MOSI):

This signal connects the master device and a slave device. Data is serially transmitted from the master device to the slave device through MOSI, the master device outputs, and the slave device inputs.

Master-In and Slave-Out (MISO):

This signal connects the slave device and the master device. Data is serially transmitted from the slave device to the master device through MISO, the slave device is output, and the master device is input. When the SPI is configured as a slave device and not selected, the MISO pin of the slave device is in a high impedance state.

SPI Serial Clock (SCK):

The SCK signal is used to control the synchronous movement of input and output data on the MOSI and MISO lines. A byte is transmitted on the wire every 8 clock cycles. If the slave is not selected, the SCK signal is ignored by the slave.

17.1.3 Operating Modes

SPI can be configured as one of master mode or slave mode. The configuration and initialization of the SPI module are completed by setting the SPI control register USnCON0 (n=0~2) and the SPI status register USnCON1. After the configuration is completed, the data transfer is completed by setting the SPI data registers USnCON2, USnCON3 (hereinafter referred to as SPD).

During SPI communication, data is shifted in and out serially synchronously. The serial clock line (SCK) keeps the movement and sampling of data on the two serial data lines (MOSI and MISO) synchronized. If the slave is not selected, it cannot participate in activities on the SPI bus.

When the SPI master device transmits data to the slave device through the MOSI line, the slave device sends the data to the master device as a response via the MISO line, which realizes the synchronous full-duplex transmission of data sending and receiving under the same clock. The sending shift register and the receiving shift register use the same special function address. Writing to the SPI data register SPD will write to the sending shift register, and reading the SPD will get the data of the receiving shift register.

The SPI interface of some devices will lead to the SS pin (slave device selection pin, active low). When communicating with the SPI of the SC95F861XB, the connection mode of the SS pin of other devices on the SPI bus needs to be connected according to different communication modes. The following table lists the connection modes of the SS pin of other devices on the SPI bus in different SPI communication modes of the SC95F861XB:

SC95F861XB SPI	Other devices on the SPI bus	Mode	Slave SS (Slave selection pin)
Master mode	Slave mode	One master and one slave	Pull down
		One master and multiple slaves	The SC95F861XB leads to multiple I/Os, which are connected to the SS pin of the slave. Before data transmission, the SS pin of the slave device must be set low
Slave mode	Master mode	One master and one slave	Pull up

Master Mode

- **Mode Startup:**

The SPI master device controls the start of all data transfers on the SPI bus. When the MSTR bit in the SPI control register USnCON0 is set to 1, the SPI runs in the master mode and only one master device can start the transfer.

- **Transmitting:**

In SPI master mode, perform the following operations on SPD: write a byte of data to SPDL in 8-bit mode or write the high byte to SPDH first, and then write the low byte to SPDL in 16-bit mode, the data will be written to the transmit shift buffer. If there is already a data in the transmit shift register, the main SPI generates a WCOL signal to indicate that the write is too fast. But the data in the transmission shift register will not be affected, and the transmission will not be interrupted. In addition, if the transmission shift register is empty, the master device immediately shifts the data in the transmission shift register to the MOSI line in accordance with the SPI clock frequency on SCK. When the transfer is complete, the SPIF bit in the SPI status register USnCON1 is set to 1. If the SPI interrupt is enabled, an interrupt will also be generated when the SPIF bit is set.

- **Receiving:**

When the master device transmits data to the slave device through the MOSI line, the corresponding slave device also transmits the contents of its transmitting shift register to the receiving shift register of the master device through the MISO line, realizing full-duplex operation. Therefore, the SPIF flag set 1 means that the transmission is complete and the data is received. The data received by the slave device is stored in the receive shift register of the master device according to the MSB or LSB first transmission direction. When a byte of data is completely moved into the receive register, the processor can obtain the data by reading the SPD.

Slave mode

- **Mode Startup:**

When the MSTR bit in the SPI control register USnCON0 register is cleared to 0, SPI runs in slave mode.

- **Transmitting and Receiving :**

In slave mode, according to the SCK signal controlled by the master device, data is shifted in through the MOSI pin, and the MISO pin is shifted out. A bit counter records the number of edges of SCK. When the receiving shift register shifts in 8-bit data (one byte) and the sending shift register shifts out 8-bit data (one byte), the SPIF flag bit is set to 1. The data can be obtained by reading the SPD register. If the SPI interrupt is enabled, an interrupt will also be generated when SPIF is set. At this time, the receiving shift register keeps the original data and the SPIF bit is 1, so that the SPI slave device will not receive any data until SPIF is cleared. The SPI slave device must write the data to be transmitted into the transmit shift register before the master device starts a new data transmission. If no data is written before starting to send, the slave device will transmit the "0x00" byte to the master device. If the SPD write operation occurs during the transfer, the WCOL flag of the SPI slave device is set to 1, that is, if the transfer shift register already contains data, the WCOL bit of the SPI slave device is set to 1, indicating that the write SPD conflicts. But the data of the shift register is not affected, and the transmission will not be interrupted.

17.1.4 Transfer Form

By software setting the CPOL bit and CPHA bit of the SPI control register USnCON0, the user can select four combinations of SPI clock polarity and phase. The CPOL bit defines the polarity of the clock, that is, the level state when idle, and it has little effect on the SPI transmission format. The CPHA bit defines the phase of the clock, that is, defines the clock edge that allows data sampling and shifting. In the two devices of master-slave communication, the setting of the clock polarity phase should be the same.

When CPHA = 0, the first edge of SCK captures data, and the slave must prepare the data before the first edge of SCK.

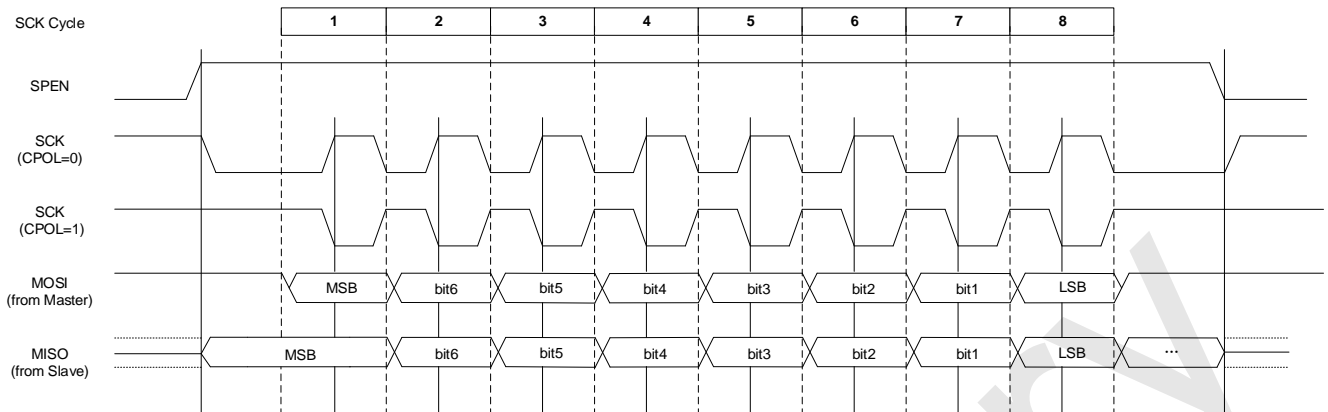

CPHA = 0 Data transfer diagram

When CPHA = 1, the master device outputs data to the MOSI line on the first edge of SCK, the slave device uses the first edge of SCK as the sending signal, and the second edge of SCK starts to capture data, So the user must write SPD inside two edges of the first SCK. This form of data transmission is the preferred form of communication between a master device and a slave device.

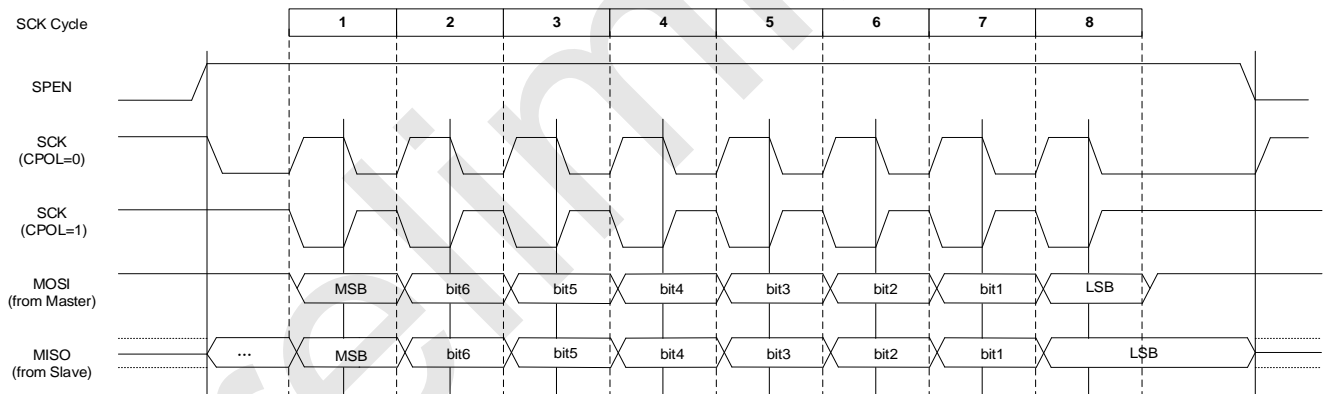

CPHA = 1 Data transfer diagram

17.1.5 Error Detection

Writing to SPD during the data transmission sequence will cause a write conflict, and the WCOL bit in the SPI status register USnCON1 is set to 1. WCOL bit 1 will not cause interruption, and transmission will not be aborted. The WCOL bit needs to be cleared by software.

17.2 TWI

USMDn[1: 0] = 10, n=0~5 One of three serial interface USCI is configured as TWI interface:

- USTXn as SDA signal
- USCKn as CLK signal

The SC95F861XB can be set as master or slave mode according to application requirements during TWI communication.

US0CON0 (95H) TWI0 Control Register 0 (read/write)

US1CON0 (A4H) TWI1 Control Register 0 (read/write)

USXCON0 (C4H) TWI2~5 Control Register 0 (read/write)

Bit number	7	6	5	4	3	2	1	0
Bit Mnemonic	TWEN	TWIF	MSTR	GCA	AA	STATE[2: 0]		
R/W	R/W	R/W	Read	Read	R/W	Read	Read	Read
POR	0	0	0	0	0	0	0	0

Bit number	Bit Mnemonic	Description
7	TWEN	TWI enable control 0: Disable TWI 1: Enable TWI
6	TWIF	TWI interrupt flag 1. Cleared by software 2. Under the following conditions, the interrupt flag bit is set by hardware: 1) Master mode: <ol style="list-style-type: none"> ① Send start signal ② After sending the address frame ③ Receive or send the data frame 2) Slave mode:

		<ul style="list-style-type: none"> ① The first frame address matches successfully ② Successfully receive or send 8-bit data ③ Receive repeated start condition ④ The slave receives a stop signal
5	MSTR	<p>Master-slave flag</p> <p>0: Slave mode</p> <p>1: Master mode</p> <p>Description:</p> <p>1. When the TWI interface sends a start condition to the bus, it will automatically switch to the master mode, and the hardware will set this bit at the same time;</p> <p>2. When a stop condition is detected on the bus, the hardware clears this bit.</p>
4	GCA	<p>General address response flag</p> <p>0: Non-response general address</p> <p>1: When GC is set to 1 and the general address matches at the same time, this bit is set to 1 by hardware and automatically cleared</p>
3	AA	<p>Answer enable bit</p> <p>0: No response, return UACK (the response bit is high)</p> <p>1: After receiving a matching address or data, a response ACK is returned</p>
2~0	STATE[2: 0]	<p>State machine status flag</p> <p>Slave mode:</p> <p>000: The slave is in the idle state, waiting for TWEN to be set to 1, and detecting the TWI start signal. When the slave receives the stop condition, the jump will go to this state</p> <p>001: The slave is receiving the first frame address and read/write bit (the 8th bit is the read/write bit, 1 is read, and 0 is write). The slave will jump to this state after receiving the start condition</p> <p>010: Slave receiving data status</p>

		<p>011: slave sending data status</p> <p>100: In the state of sending data from the slave, when the master returns to UACK, it jumps to this state and waits for a restart signal or a stop signal.</p> <p>101: When the slave is in the sending state, writing 0 to AA will enter this state, waiting for a restart signal or a stop signal.</p> <p>110: If the address of the slave does not match the address sent by the master, it will jump to this state and wait for a new start condition or stop condition.</p> <p>Master mode:</p> <p>000: The state machine is idle</p> <p>001: The Master sends the start condition or the Master is sending the slave device address</p> <p>010: Master sends data</p> <p>011: Master receives data</p> <p>100: The master sends a stop condition or receives a UACK signal from the slave</p>
--	--	---

US0CON1 (9DH) TWI0 Control Register 1 (read/write)
US1CON1 (A5H) TWI1 Control Register 1 (read/write)
USXCON1 (C5H) TWI2~5 Control Register 1 (read/write)

Bit number	7	6	5	4	3	2	1	0
Bit Mnemonic	TXnE/ RXnE	STRETCH	STA	STO	TWCK[3: 0]			
R/W	Read Only	R/W	R/W	R/W	R/W	R/W	R/W	R/W
POR	0	0	0	0	0	0	0	0

Bit number	Bit Mnemonic	Description
7	TXnE/RXnE	<p>Send/receive complete flag</p> <p>In the following situations, TXnE/RXnE is set to 1</p> <p>Master mode:</p> <ul style="list-style-type: none"> ① The Master sends an address frame (write) and receives an ACK from the slave ② The master sends the data and receives the slave ACK ③ The Master receives the data, and the Master returns an ACK to the slave <p>Slave mode:</p> <ul style="list-style-type: none"> ① The slave receives the address frame (read), and it matches the slave address (TWA) ② The slave receives the data, and the slave returns an ACK to the master ③ The slave sends the data and receives the master ACK (AA=1) <p>Reading and writing to TWIDAT will clear this flag.</p>
6	STRETCH	<p>Allow clock extension (slave mode)</p> <p>0: disable clock extension</p> <p>1: Allow clock extension, the Master needs to support the clock extension function</p> <p>Description: After the data transmission is completed, and ACK is 0, clock stretching occurs at this time</p>
5	STA	<p>Start bit</p> <p>Set "1" to generate start condition, TWI will switch to Master mode</p> <p>Software can set or clear this bit, or it can be cleared by hardware when the start condition is issued.</p>
4	STO	<p>Master mode stop bit</p>

		<p>Set to "1" in the Master mode, a stop condition will be generated after the current byte is transmitted or the start condition is sent</p> <p>Software can set or clear this bit, or it can be cleared by hardware when a stop condition is detected.</p>
3~0	TWCK[3: 0]	<p>TWI communication rate setting in Master mode:</p> <p>0000: $f_{SYS}/1024$</p> <p>0001: $f_{SYS}/512$</p> <p>0010: $f_{SYS}/256$</p> <p>0011: $f_{SYS}/128$</p> <p>0100: $f_{SYS}/64$</p> <p>0101: $f_{SYS}/32$</p> <p>0110: $f_{SYS}/16$</p> <p>Others: Reserved</p> <p>Note:</p> <p>1. The setting is invalid in slave mode. The maximum clock frequency is 400 kHz;</p> <p>2. The clock source of TWI follow the System clock f_{SYS}</p>
7	-	Reserved

US0CON2 (9EH) TWI0 Address Register (read/write)

US1CON2 (A6H) TWI1 Address Register (read/write)

USXCON2 (C6H) TWI2~5 Address Register (read/write)

Bit number	7	6	5	4	3	2	1	0
Bit Mnemonic	TWA[6: 0]							GC
R/W	R/W	R/W	R/W	R/W	R/W	R/W	R/W	R/W
POR	0	0	0	0	0	0	0	0

Bit number	Bit Mnemonic	Description
7~1	TWA[6: 0]	TWI address register TWA[6: 0] cannot be written as all 0s, 00H is dedicated to general address addressing. Invalid setting in Master mode
0	GC	TWI general address enable 0: Forbid to respond to general address 00H 1: Allow response to general address 00H

US0CON3 (9FH) TWI0 Data Buffer Register (read/write)

US1CON3 (A7H) TWI1 Data Buffer Register (read/write)

USXCON3 (C7H) TWI2~5 Data Buffer Register (read/write)

Bit number	7	6	5	4	3	2	1	0
Bit Mnemonic	TWDAT[7: 0]							
R/W	R/W	R/W	R/W	R/W	R/W	R/W	R/W	R/W
POR	0	0	0	0	0	0	0	0

Bit number	Bit Mnemonic	Description
7~0	TWDAT[7: 0]	TWI Data buffer register

17.2.1 Signal Description

TWI Clock Signal Line(SCL)

The clock signal is sent by the master and connected to all slaves. One byte of data is transmitted every 9 clock cycles. The first 8 cycles are used for data transmission, and the last clock is used as the receiver's response clock. It should be high when it is idle, pulled up by the pull-up resistor on the SCL line.

TWI Data Signal Line(SDA)

SDA is a bidirectional signal line, which should be high when it is idle, and is pulled high by the pull-up resistor on the SDA line.

17.2.2 Slave Operating Mode

- **Mode Start:**

When the TWI enable flag is turned on (TWEN = 1) and the start signal sent by the Master is received at the same time, the mode is started.

The slave enters the state of receiving the first frame address (STATE[2: 0] = 001) from the idle mode (STATE[2: 0] = 000), and waits for the first frame of data from the master. The first frame of data is sent by the Master, including 7-bit address bits and 1 bit for reading and writing. All slaves on the TWI bus will receive the first frame of data from the Master. The Master releases the SDA signal line after sending the first frame of data. If the address sent by the Master is the same as the value in a slave's own address register, it means that the slave is selected. The selected slave will judge the 8th bit on the bus, that is, the data read and write bit (=1, read command) ;=0, write command), then occupy the SDA signal line, give the Master a low-level response signal in the 9th clock cycle of SCL, and then release the bus. After the slave is selected, it will enter different states according to the different read and write bits:

- **Non-general Address Response, Slave Device Receiving Mode:**

If the read/write bit received in the first frame is write (0), the slave enters the slave receiving state (STATE[2: 0] = 010) and waits for the data sent by the Master. The master must release the bus every time it sends 8 bits and wait for the response signal from the slave in the 9th cycle.

1. If the response signal of the slave is low, the communication of the master can be in the following three ways:
 - 1) Continue to send data;
 - 2) Resend the start signal (start), at this time the slave re-enters the state of receiving the first frame address (STATE[2: 0] = 001);
 - 3) Send a stop signal to indicate the end of this transmission, and the slave returns to the idle state, waiting for the next start signal from the Master.

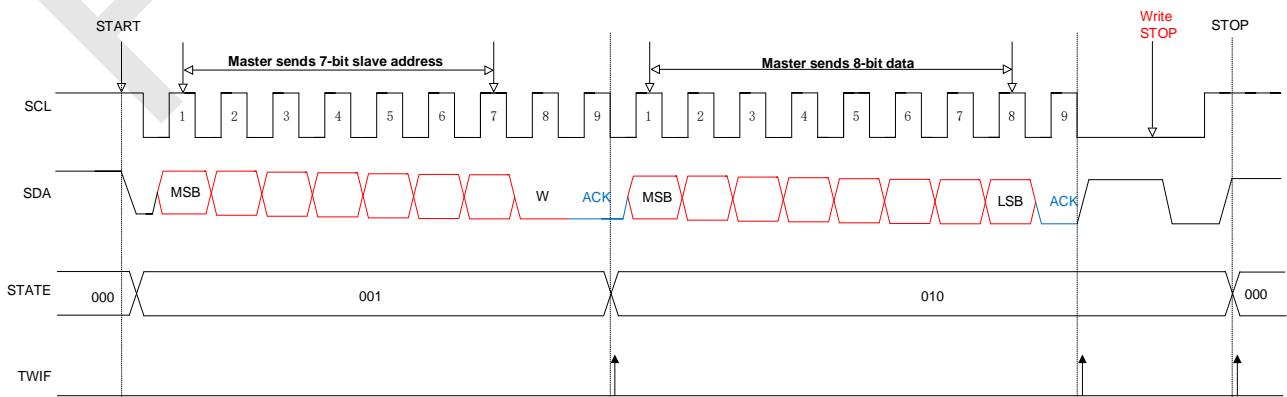

- If the slave responds to a high level (during the receiving process, the AA value in the slave register is rewritten to 0), it means that after the current byte is transmitted, the slave will actively end the transmission and return to the idle state (STATE[2: 0] = 000), no longer receive data from the Master.

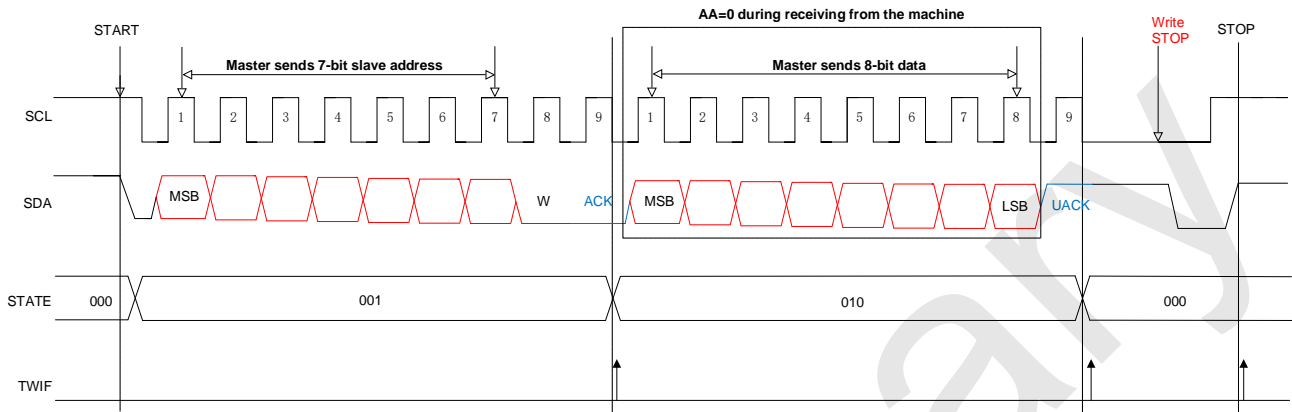

- Non-general Address Response, Slave Device Transmitting Mode:**

If the read/write bit received in the first frame is read (1), the slave will occupy the bus and send data to the Master. Every time 8 bits of data are sent, the slave releases the bus and waits for the response from the master:

- If the master responds with a low level, the slave continues to send data. In the process of sending, if the AA value in the slave register is rewritten to 0, the slave will actively end the transmission and release the bus after the current byte is transmitted, and wait for the stop signal or restart signal of the master (STATE[2: 0] = 101).

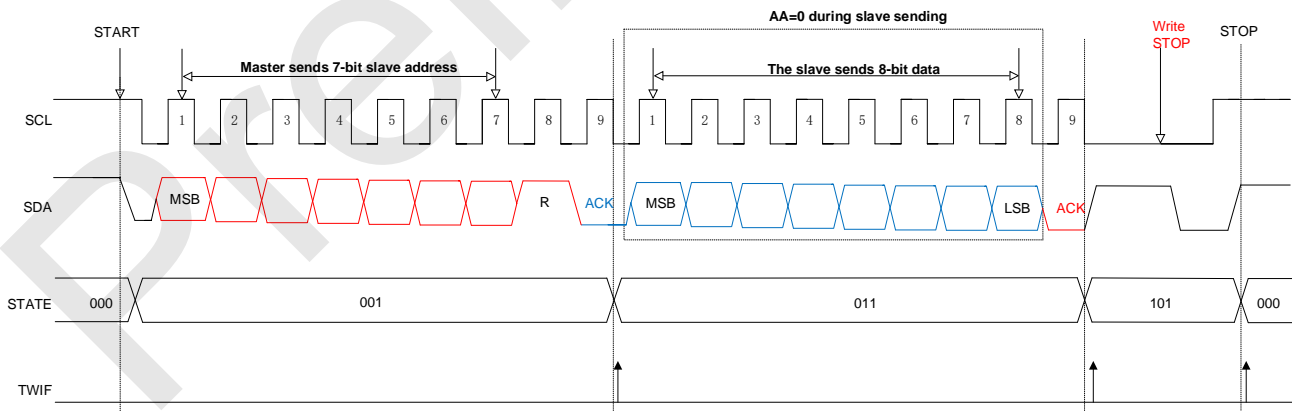

- If the master responds to a high level, the slave STATE[2: 0] = 100, waiting for the master's stop signal or restart signal.

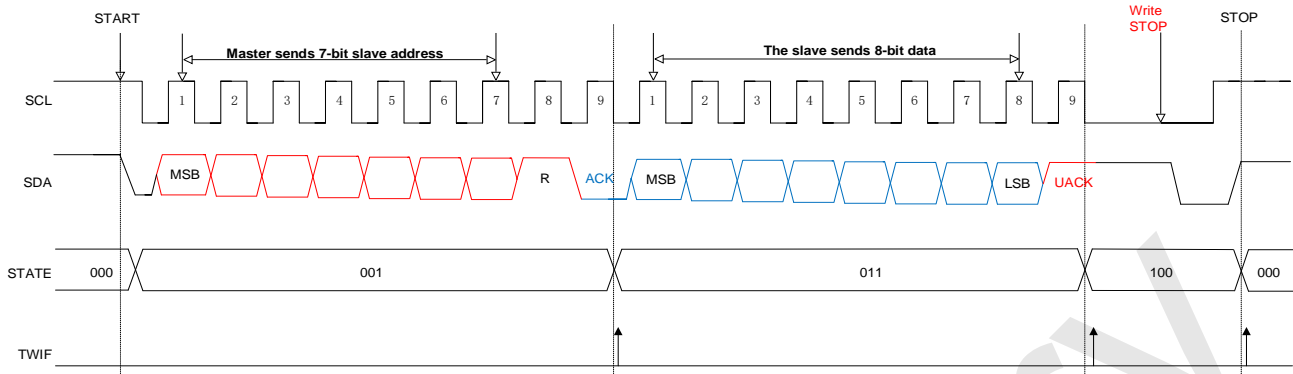

● **General Address Response:**

When GC=1, the general address is allowed to be used at this time. The slave enters the state of receiving the first frame address (STATE[2: 0] = 001), the address bit data in the first frame of data received is 0x00, and all slaves respond to the master at this time. The read and write bits sent by the master must be write (0), and all slaves enter the state of receiving data (STATE[2: 0] = 010) after receiving. The Master releases the SDA line every time 8 data is sent, and reads the status on the SDA line:

1. If there is a response from the slave, the communication of the master can be in the following three ways:
 - 1) Continue to send data;
 - 2) Restart;
 - 3) Send a stop signal to end this communication.

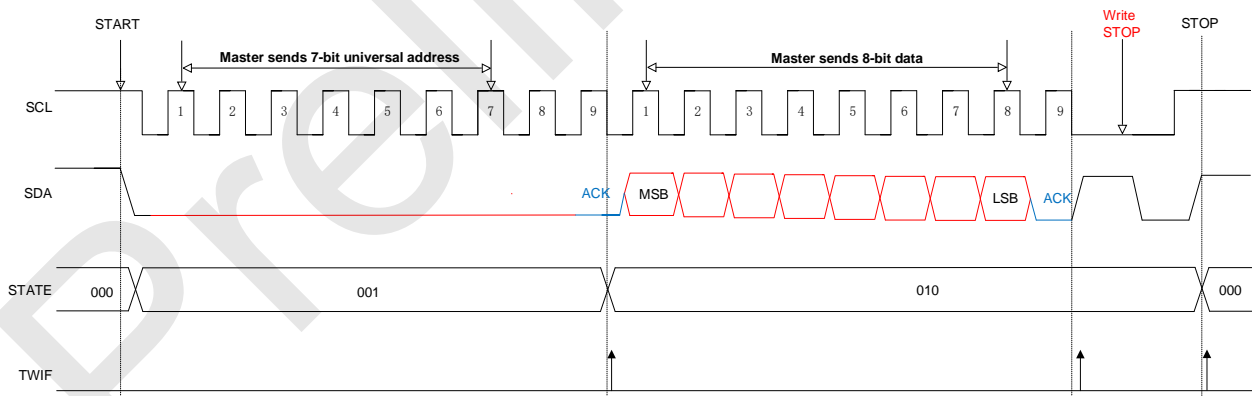

2. If no slave responds, SDA is idle.

Note: When using the universal address in the one-master multiple-slave mode, the read and write bits sent by the Master cannot be in the read (1) state, otherwise, all devices on the bus will respond except for the device sending the data.

17.2.3 Slave Mode Operation Steps

1. Configure USMDn[1: 0] and select TWI mode;
2. Configure the TWIn control registers USnCON0 and USnCON1;
3. Configure the TWI address register USnCON2;
4. If the slave receives data, it waits for the interrupt flag bit TWIF in USnCON0 to be set. Every time the slave receives 8 bits of data, TWIF will be set to 1. The interrupt flag bit TWIF needs to be manually cleared;
5. If the slave sends data, write the data to be sent into TWDAT, and TWI will automatically send the data. Every 8 bits are sent, the interrupt flag bit TWIF will be set.

17.2.4 Master operating Mode

- **Mode startup:**

When the TWI interface sends an initial condition to the bus, it will automatically switch to the main mode, and the hardware will set the MSTR bit to 1. The Master state bit STATE[2: 0] switches from 000 to 001, and the interrupt condition TWIF is set to 1.

- **TWI Master sending mode:**

In the master sending mode, the first frame of data sent by the master includes 7 address bits (selected slave address) and 1 read/write bit (=0, write command). All slaves on the TWI bus will receive the master The first frame of data. The Master releases the SDA signal line after sending the first frame of data. The selected slave sends a response signal to the master in the 9th clock cycle of SCL, and then releases the bus and enters the slave receiving state to wait for the data sent by the master. The master must release the bus every time it sends 8 bits and wait for the response signal from the slave in the 9th cycle.

1. If the slave responds low, the master can continue to send data. You can also resend the start signal:

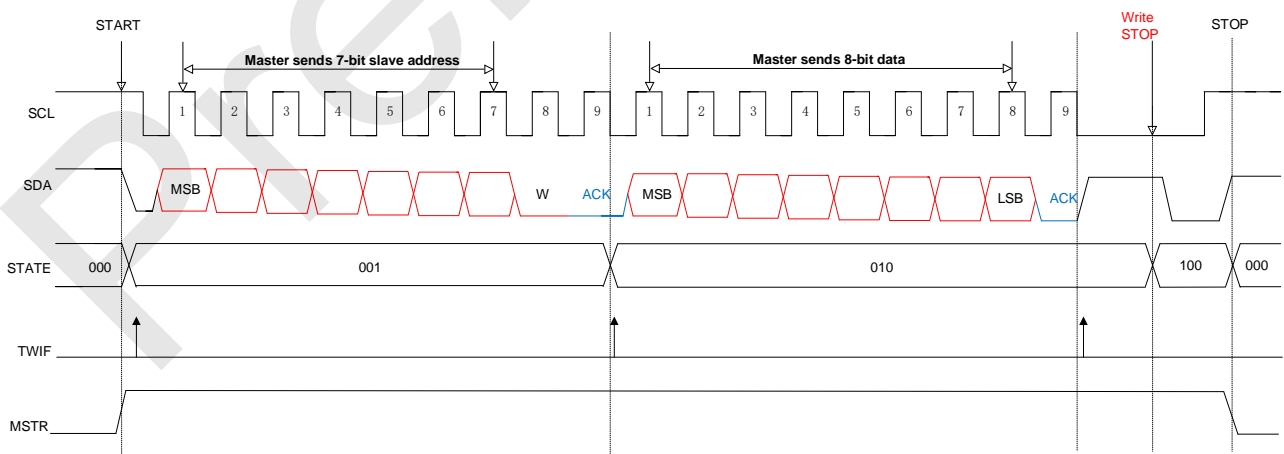

2. If the slave responds to a high level, it means that after the current byte has been transmitted, the slave will actively end this transmission and will no longer receive the data sent by the master. The master STATE[2: 0] will switch from the sending data state 010 to 100:

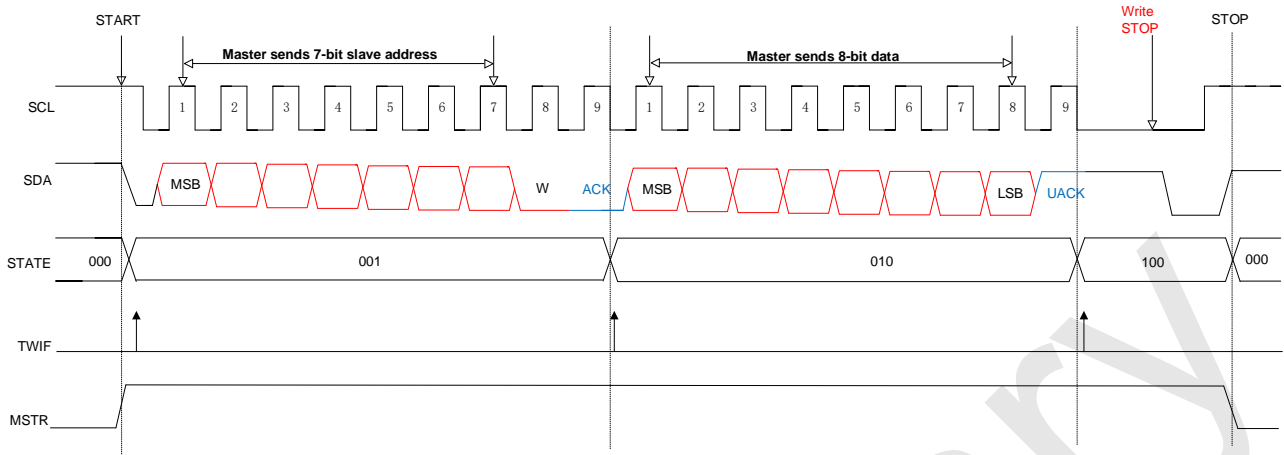

- **TWI Master Receiving Mode:**

In the master sending mode, the first frame of data sent by the master includes a 7-bit address bit (selected slave address) and a 1-bit read and write bit (=1, read command). All slaves on the TWI bus will receive the first frame of data to the Master. The Master releases the SDA signal line after sending the first frame of data. The selected slave sends an acknowledge signal to the master in the 9th clock cycle of SCL, and then will occupy the bus and send data to the master. Every time 8 bits of data are sent, the slave releases the bus and waits for the response from the master. The Master receives the response signal ACK after the slave address is successfully matched, and starts to receive the slave data (STATE=011):

1. If the Master response bit is enabled (AA=1), every time a BYTE data is received, the Master responds with the response signal ACK, and TWIF is set;
2. Before receiving the last byte of data, if the response enable bit is turned off (AA=0), the Master will reply UACK after receiving the last byte of data, and then the Master can send a stop signal.

In the Master receiving mode, the way to actively release the bus is as follows:

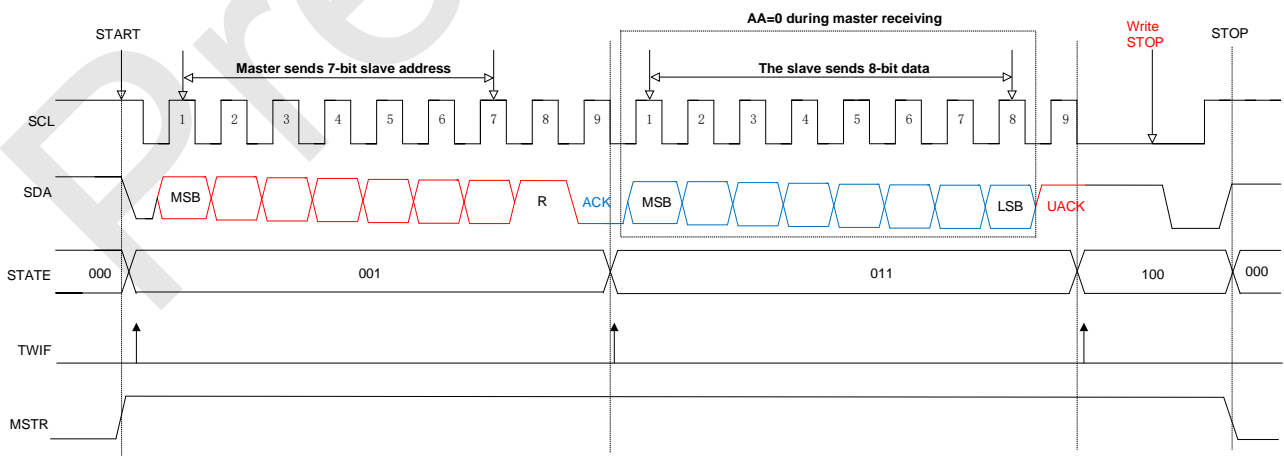

17.2.5 Master Mode Operation Steps

1. Configure USMDn[1: 0] and select TWI mode;

2. Configure the TWIn control register USnCON0: TWEN = 1, enable TWI
3. Configure the TWIn control register USnCON1: configure the TWI communication rate (TWCK[3: 0]), set the start bit STA to "1"
4. Configure TWIn address register USnCON3: write "slave address plus read and write bits" into TWDAT, and send out an address frame on the bus
5. If the Master receives data, it waits for the interrupt flag bit TWIF in USnCON0 to be set 1. When the Master receives 8 bits of data, the interrupt flag bit will be set. The interrupt flag bit needs to be manually cleared;
6. If the Master sends data, write the data to be sent into TWDAT, and TWI will automatically send the data. Every 8 bits are sent, the interrupt flag bit TWIF will be set 1.
7. After the data is sent and received, the Master can send a stop condition (STO=1), and the Master state switches to 000. Or send a repeated start signal to start a new round of data transmission.

The TWIF of the Master will not be set after the Master generates a stop!

17.3 Serial Interface (UART)

USMDn[1: 0] = 11, n=0~2 one of three serial interface USCI is configured as UART interface. It can be easily used to connect with other devices or equipment, such as Wifi module circuit or other UART communication interface driver chip. Its functions and characteristics are as follows:

1. Three communication modes are available: mode 0, mode 1 and mode 3;
2. Independent baud rate generator;
3. The interrupt RI/TI can be generated after sending and receiving, and the interrupt flag needs to be cleared by software, the clearing mode is "Write 1 clear".
4. Can realize full duplex communication

When USCI is configured as UART interface: :

- USTXn as TX signal
- USRXn as RX signal

US0CON0 (95H) Serial Port 1 Control Register (read/write)

US1CON0 (A4H) Serial Port 2 Control Register (read/write)

USXCON0 (C4H) Serial Port 3~6 Control Register (read/write)

Bit number	7	6	5	4	3	2	1	0
Bit Mnemonic	SM0	SM1	SM2	REN	TB8	RB8	TI	RI
R/W	R/W	R/W	R/W	R/W	R/W	R/W	R/ Write 1 clear	R/ Write 1 clear
POR	0	0	0	0	0	0	0	0

Bit number	Bit Mnemonic	Description
7~6	SM0~1	Serial communication mode control bit 00: Mode 0, 8-bit half-duplex synchronous communication mode, serial data is sent and received on the RX pin. The TX pin is used as the

		<p>transmit shift clock. 8 bits are sent and received per frame, and the lower bits are received or sent first;</p> <p>01: Mode 1, 10-bit full-duplex asynchronous communication, composed of 1 start bit, 8 data bits and 1 stop bit, and the communication baud rate is variable;</p> <p>10: Reserved;</p> <p>11: Mode 3, 11-bit full-duplex asynchronous communication, composed of 1 start bit, 8 data bits, a programmable 9th bit and 1 stop bit, and the communication baud rate is variable.</p>
5	SM2	<p>Serial communication mode control bit 2, this control bit is only valid for mode 3</p> <p>0: Set RI every time a complete data frame is received to generate an interrupt request;</p> <p>1: When a complete data frame is received, RI will be set to generate an interrupt request only when RB8=1.</p> <p>Baud rate multiplier setting bit, only valid in mode 0 (SM0~1 = 00):</p> <p>0: The serial port runs at 1/12 of the system clock</p> <p>1: The serial port runs at 1/4 of the system clock</p>
4	REN	<p>Receive permission control bit</p> <p>0: It is not allowed to receive data;</p> <p>1: Allow to receive data.</p>
3	TB8	Only valid for mode 3, which is the 9th bit of the transmitted data
2	RB8	Only valid for mode 3, which is the 9th bit of the received data
1	TI	Send interrupt flag
0	RI	Receive interrupt flag

US0CON1 (9DH) Serial Port 1 Baud Rate Control Register Low Bit (read/write)

US1CON1 (A5H) Serial Port 2 Baud Rate Control Register Low Bit (read/write)

USXCON1 (C5H) Serial Port 3~6 Baud Rate Control Register Low Bit (read/write)

Bit number	7	6	5	4	3	2	1	0
Symbol	BAUD1L [7: 0]							
Read/ Write	Read/ Write	Read/ Write	Read/ Write	Read/ Write	Read/ Write	Read/ Write	Read/ Write	Read/ Write
Initial power-on value	0	0	0	0	0	0	0	0

US0CON2 (9EH) Serial Port 1 Baud Rate Control Register High Bit (read/write)

US1CON2 (A6H) Serial Port 2 Baud Rate Control Register High Bit (read/write)

USXCON2 (C6H) Serial Port 3~6 Baud Rate Control Register High Bit (read/write)

Bit number	7	6	5	4	3	2	1	0
Symbol	BAUD1H [7: 0]							
Read/ Write	Read/ Write	Read/ Write	Read/ Write	Read/ Write	Read/ Write	Read/ Write	Read/ Write	Read/ Write
Initial power-on value	0	0	0	0	0	0	0	0

Bit number	Bit Mnemonic	Description
7~0	BAUD1 [15: 0]	USCI Serial port baud rate control $\text{BaudRate} = \frac{f_{\text{sys}}}{[\text{BAUD1H}, \text{BAUD1L}]}$

		Note: [BAUD1H,BAUD1L] must be greater than 0x0010
--	--	---

US0CON3 (9FH) Serial 1 Data Buffer Register (read/write)

US1CON3 (A7H) Serial 2 Data Buffer Register (read/write)

USXCON3 (C7H) Serial 3~6 Data Buffer Register (read/write)

Bit number	7	6	5	4	3	2	1	0
Bit Mnemonic	SBUF1[7: 0]							
R/W	R/W	R/W	R/W	R/W	R/W	R/W	R/W	R/W
POR	0	0	0	0	0	0	0	0

Bit number	Bit Mnemonic	Description
7~0	SBUF1[7: 0]	Serial Data Buffer Register SBUF1 contains two registers: a sending shift register and a receiving latch. The data written in SBUF1 will be sent to the sending shift register and the sending process will be started. Reading SBUF1 will return the contents of the receiving latch.

18 High-speed Analog-to-Digital Converter (ADC)

The SC95F861XB integrates 17 channels of 12-bit high-precision 1M high-speed ADC, and the external 16 channels of ADC and other functions of the IO port are multiplexed. The internal channel can be connected to 1/4 VDD, and the internal 2.048V, 1.024V or 2.4V reference voltage is used for Measure the VDD voltage. 1 MHz super-high-speed sampling clock, the total time from sampling to completion of conversion is as low as 2 μ s

There are 4 choices for the ADC reference voltage of SC95F861XB:

- ① VDD pin (that is directly the internal VDD);
- ② The reference voltage output by the internal Regulator is accurately 2.048V.
- ③ The reference voltage output by the internal Regulator is exactly 1.024V.
- ④ The reference voltage output by the internal Regulator is exactly 2.4V.

18.1 ADC-related Registers

ADCCON (ADH) ADC Control Register (read/write)

Bit number	7	6	5	4	3	2	1	0
Bit Mnemonic	ADCEN	ADCS	EOC/ADCIF	ADCIS[4: 0]				
R/W	R/W	R/W	R/W	R/W	R/W	R/W	R/W	R/W
POR	0	0	0	0	0	0	0	n

Bit number	Bit Mnemonic	Description
7	ADCEN	Power on ADC 0: Disable the ADC module power 1: Enable the ADC module power
6	ADCS	ADC start trigger control (ADC Start) Write "1" to this bit to start ADC conversion, that is, this bit is only the trigger signal of ADC conversion. This bit can only be written with 1 to be valid.

		Note: After writing "1" to the ADCS, do not write to the ADCCON register until the interrupt flag EOC/ADCIF is set.
5	EOC /ADCIF	<p>Conversion complete/ADC Interrupt Flag (End Of Conversion / ADC Interrupt Flag)</p> <p>0: Conversion has not been completed</p> <p>1: ADC conversion is complete. Need user software to clear</p> <p>ADC conversion complete flag EOC: when the user sets ADCS to start conversion, this bit will be automatically cleared to 0 by the hardware; when the conversion is completed, this bit will be automatically set to 1 by the hardware;</p> <p>ADC interrupt request flag ADCIF:</p> <p>This bit is also used as an interrupt request flag for ADC interrupt. If the user enables the ADC interrupt, the user must clear this bit by software after the ADC interrupt occurs.</p>
4~0	ADCIS[4: 0]	<p>ADC Input Selector (ADC Input Selector)</p> <p>00000: select AIN0 as ADC input</p> <p>00001: select AIN1 as ADC input</p> <p>00010: Use AIN2 as ADC input</p> <p>00011: Choose AIN3 as ADC input</p> <p>00100: Choose AIN4 as ADC input</p> <p>00101: Choose AIN5 as ADC input</p> <p>00110: select AIN6 as ADC input</p> <p>00111: Choose AIN7 as ADC input</p> <p>01000: select AIN8 as ADC input</p> <p>01001: select AIN9 as ADC input</p> <p>01010: Choose AIN10 as ADC input</p> <p>01011: select AIN11 as ADC input</p> <p>01100: AIN12 is selected as ADC input</p> <p>01101: Choose AIN13 as ADC input</p> <p>01110: Select AIN14 as ADC input</p> <p>01111: select AIN15 as ADC input</p>

		10000~11110: reserved 11111: ADC input is 1/4 V _{DD} , which can be used to measure power supply voltage
--	--	--

ADCCFG2 (B5H) ADC Set Register 2 (read/write)

Bit number	7	6	5	4	3	2	1	0
Symbol	-	-	-	LOWSP[2: 0]			-	-
Read/ Write	-	-	-	Read/ Write	Read/ Write	Read/ Write	-	-
Initial power-on value	x	x	x	0	0	0	x	x

Bit number	Bit Mnemonic	Description
4~2	LOWSP[2: 0]	<p>ADC sampling period selection:</p> <p>100: The sampling time is 3 system clocks, (about 100ns @f_{sys} = 32 MHz)</p> <p>101: The sampling time is about 6 system clocks, (about 200ns @f_{sys} = 32 MHz)</p> <p>110: The sampling time is about 16 system clocks, (about 500ns @ f_{sys} = 32 MHz)</p> <p>111: The sampling time is about 32 system clocks, (about 1000ns @ f_{sys} = 32 MHz)</p> <p>Other: Reserved</p> <p>Description: The total time from ADC sampling to completion of conversion T_{ADC} = sampling time + conversion time</p> <p>The ADC conversion time is fixed at 950ns.</p>

7~5, 1~0	-	Reserved
----------	---	----------

ADCCFG0 (ABH) ADC Set Register 0 (read/write)

Bit number	7	6	5	4	3	2	1	0
Bit Mnemonic	EAIN7	EAIN6	EAIN5	EAIN4	EAIN3	EAIN2	EAIN1	EAIN0
R/W	R/W	R/W	R/W	R/W	R/W	R/W	R/W	R/W
POR	0	0	0	0	0	0	0	0

ADCCFG1 (ACH) ADC Set Register 1 (read/write)

Bit number	7	6	5	4	3	2	1	0
Bit Mnemonic	EAIN15	EAIN14	EAIN13	EAIN12	EAIN11	EAIN10	EAIN9	EAIN8
R/W	R/W	R/W	R/W	R/W	R/W	R/W	R/W	R/W
POR	0	0	0	0	0	0	0	0

Bit number	Bit Mnemonic	Description
0	EAINx (x=0~15)	ADC port setting register 0: Set AINx as IO port 1: Set AINx as ADC input and automatically remove the pull-up resistor.

OP_CTM1 (C2H@FFH) Code Option Register 1(read/write)

Bit number	7	6	5	4	3	2	1	0
Bit Mnemonic	VREFS[1: 0]		OP_BL	DISJTG	IAPS[1: 0]		LDSIZE[1:0]	
R/W	R/W	R/W	R/W	R/W	R/W	R/W	Read only	
POR	n	n	n	n	n	n	n	n

Bit number	Bit Mnemonic	Description
7~6	VREFS[1: 0]	Reference voltage selection (the initial value is transferred from Customer Option, the user can modify the setting) 00: Set VREF of ADC to VDD; 01: Set the VREF of ADC to the internal accurate 2.048V; 10: Set the VREF of ADC to the internal accurate 1.024V; 11: Set the VREF of ADC to the internal accurate 2.4V;

ADCVL (AEH) ADC Conversion Value Register (low bit) (read/write)

Bit number	7	6	5	4	3	2	1	0
Bit Mnemonic	ADCV[3: 0]				-	-	-	-
R/W	R/W	R/W	R/W	R/W	-	-	-	-
POR	1	1	1	1	x	x	x	x

ADCVH (AFH) ADC Conversion Value Register (high bit) (read/write)

Bit number	7	6	5	4	3	2	1	0
Bit Mnemonic	ADCV[11: 4]							
R/W	R/W	R/W	R/W	R/W	R/W	R/W	R/W	R/W
POR	1	1	1	1	1	1	1	1

Bit number	Bit Mnemonic	Description
11~4	ADCV[11: 4]	The high 8-bit value of ADC conversion value
3~0	ADCV[3: 0]	Low 4 bits of ADC conversion value

IE (A8H) Interrupt Enable Register (read/write)

Bit number	7	6	5	4	3	2	1	0
Bit Mnemonic	EA	EADC	ET2	EUART	ET1	EINT1	ET0	EINT0
R/W	R/W	R/W	R/W	R/W	R/W	R/W	R/W	R/W
POR	0	0	0	0	0	0	0	0

Bit number	Bit Mnemonic	Description
6	EADC	ADC interrupt enable control 0: Do not allow EOC/ADCIF to generate interrupts 1: Enable EOC/ADCIF to generate interrupt

IP (B8H) Interrupt Priority Control Register (read/write)

Bit number	7	6	5	4	3	2	1	0
Bit Mnemonic	-	IPADC	IPT2	IPUART	IPT1	IPINT1	IPT0	IPINT0
R/W	-	R/W	R/W	R/W	R/W	R/W	R/W	R/W
POR	x	0	0	0	0	0	0	0

Bit number	Bit Mnemonic	Description
6	IPADC	ADC interrupt priority selection 0: Set the interrupt priority of ADC to "low" 1: Set the interrupt priority of ADC to "High"

18.2 ADC Conversion Steps

The actual operation steps required for the user to perform ADC conversion are as follows:

- ① Set the ADC input pin; (set the bit corresponding to AINx as ADC input, usually the ADC pin will be fixed in advance);
- ② Set ADC reference voltage Vref, set the frequency used for ADC conversion;
- ③ Enable the ADC module power supply;
- ④ Select ADC input channel; (set ADCIS bit, select ADC input channel);
- ⑤ Start ADCS and start conversion;
- ⑥ Wait for EOC/ADCIF=1. If the ADC interrupt is enabled, the ADC interrupt will be generated. The user needs to clear the EOC/ADCIF flag by software;
- ⑦ Get 12-bit data from ADCVH and ADCVL, first high bit and then low bit, one conversion is completed;
- ⑧ If you do not change the input channel, repeat steps 5~7 for the next conversion.

Note: Before setting IE[6] (EADC), the user is better to clear EOC/ADCIF with software, and also clear the EOC/ADCIF when the ADC interrupt service routine is executed to avoid continuous ADC interrupts. .

Preliminary

19 Analog Comparator

The SC95F861XB has a built-in analog comparator(CMP), CMP interrupt can wake up STOP mode. It can be used for alarm circuit, power supply voltage monitoring circuit, zero-crossing detection circuit, etc.

This comparator has four analog signal positive input terminals: CMP0~3, which can be switched through CMPIS [1: 0]. The negative input voltage can be switched to one of the external voltage on the CMPP pin or the internal 16-level comparison voltage through CMPRF[3: 0].

CMPIM[1: 0] can conveniently set the interrupt mode of the comparator. When the interrupt condition set by CMPIM[1: 0] occurs, the comparator interrupt flag CMPIF will be set to 1, and the interrupt flag needs to be cleared by software.

19.1 Block Diagram of Analog Comparator

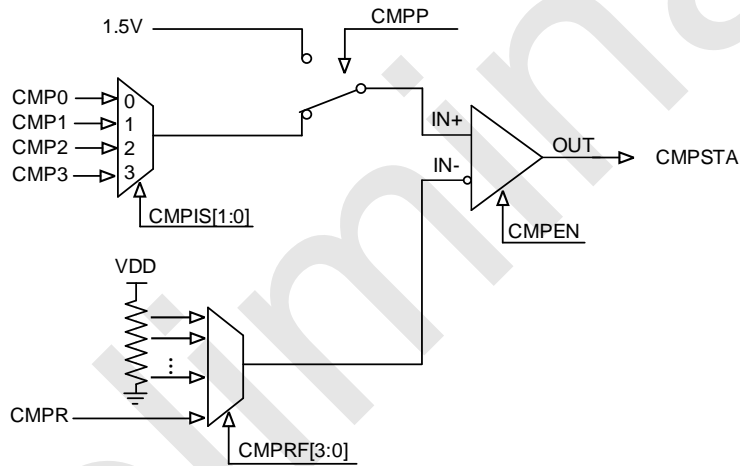

Block Diagram of Analog Comparator

CMPCON (B7H) Analog Comparator Control Register (read/write)

Bit number	7	6	5	4	3	2	1	0
Bit Mnemonic	CMPEN	CMPIF	CMPSTA	-	CMPRF[3: 0]			
R/W	R/W	R/W	R/W	-	R/W	R/W	R/W	R/W
POR	0	0	0	x	0	0	0	0

Bit number	Bit Mnemonic	Description
7	CMPEN	Analog comparator enable control bit 0: Disable the analog comparator; 1: Enable analog comparator
6	CMPIF	Analog comparator interrupt flag 0: Comparator interrupt is not triggered; 1: When the comparator meets the interrupt trigger condition, this bit will be automatically set to 1 by the hardware. If IE1[5] (ECMP) is also set to 1 at this time, the comparator interrupt is generated. After the comparator interrupt occurs, the hardware will not automatically clear this bit, the user's software must be responsible for clearing this bit.
5	CMPSTA	Analog comparator output status 0: The voltage at the positive terminal of the comparator is less than the voltage at the negative terminal 1: The voltage at the positive terminal of the comparator is greater than the voltage at the negative terminal
3~0	CMPRF[3: 0]	Analog comparator negative terminal comparison voltage selection: 0000: Choose CMPR as the comparison voltage of the analog comparator; 0001: Select $1/16V_{DD}$ as the comparison voltage of the analog comparator; 0010: Select $2/16V_{DD}$ as the comparison voltage of the analog comparator; 0011: Choose $3/16V_{DD}$ as the comparison voltage of the analog comparator; 0100: Choose $4/16V_{DD}$ as the comparison voltage of the analog comparator; 0101: Choose $5/16V_{DD}$ as the comparison voltage of the analog comparator; 0110: Choose $6/16V_{DD}$ as the comparison voltage of the analog comparator;

		<p>0111: Select 7/16V_{DD} as the comparison voltage of the analog comparator;</p> <p>1000: Select 8/16V_{DD} as the comparison voltage of the analog comparator;</p> <p>1001: Select 9/16V_{DD} as the comparison voltage of the analog comparator;</p> <p>1010: Select 10/16V_{DD} as the comparison voltage of the analog comparator;</p> <p>1011: Choose 11/16V_{DD} as the comparison voltage of the analog comparator;</p> <p>1100: Select 12/16V_{DD} as the comparison voltage of the analog comparator;</p> <p>1101: Select 13/16V_{DD} as the comparison voltage of the analog comparator;</p> <p>1110: Select 14/16V_{DD} as the comparison voltage of the analog comparator;</p> <p>1111: Select 15/16V_{DD} as the comparison voltage of the analog comparator;</p>
4	-	Reserved

CMPCFG (B6H) Analog Comparator Setting Register (read/write)

Bit number	7	6	5	4	3	2	1	0
Bit Mnemonic	-	-	-	CMPP	CMPIM[1: 0]		CMPIS[1: 0]	
R/W	-	-	-	R/W	R/W	R/W	R/W	R/W
POR	x	x	x	0	0	0	0	0

Bit number	Bit Mnemonic	Description
------------	--------------	-------------

4	CMPP	Analog comparator positive input options: 0: The positive input of the analog comparator is CMP0~3, which is set by CMPIS[1:0] 1: The positive input of the analog comparator is the internal 1.5V reference voltage
3~2	CMPIM[1: 0]	Analog comparator interrupt mode selection: 00: no interrupt 01: Rising edge interrupt: An interrupt will be generated after IN+ is less than IN- to greater than IN-; 10: Falling edge interrupt: An interrupt will be generated after IN+ is greater than IN- to less than IN-; 11: Double-edge interrupt: IN+ from less than IN- to greater than IN-, or IN+ from greater than IN- to less than IN- will generate an interrupt;
1~0	CMPIS[1: 0]	Analog comparator positive terminal input channel selection: When CMPP is 1, this bit is invalid 00: Choose CMP0 as the input of the positive terminal of the analog comparator; 01: Select CMP1 as the input of the positive terminal of the analog comparator; 10: Select CMP2 as the input of the positive terminal of the analog comparator; 11: Choose CMP3 as the input of the positive terminal of the analog comparator;
7~5	-	Reserved

20 High Sensitivity TouchKey Circuits

The SC95F861XB has a 31-channel high sensitivity capacitive touch circuit. Its features are as follows:

1. High sensitivity mode can be adapted to touch applications requiring high sensitivity, such as spacer button touch control and proximity induction
2. Support self-mutual capacitance mode
3. It can realize 31 touch control keys and derivative functions
4. High flexibility to develop software library support, low development difficulty
5. Automated debugging software support, intelligent development
6. The touch module can work in the low-power mode under the MCU Stop mode

20.1 Power Consumption of TouchKey Circuits

The SC95F861XB allows touch scanning to be enabled in STOP Mode: this approach can reduce the overall power consumption of the MCU for touch applications with low-power requirements.

Users can understand that the touch circuit of SC95F861XB has two power consumption modes:

1. Normal operation mode
2. Low-power operation mode

The two power consumption modes are defined as follows:

instructions	Normal operation mode	Low-power operation mode
CPU	RUN (Normal mode)	Stop (STOP Mode)
Touch the circuit	RUN	RUN

Note: Users can realize the required touch functions quickly and simply by using the touch button library file provided by SinOne (which can be downloaded from the official website of SinOne).

21 CRC Module

The SC95F861XB has a built-in hardware CRC module. During the CRC execution calculation, the CPU keeps the program counter. After the CRC calculation is completed, the program counter continues to execute the following instructions.

The module has two calculation modes:

Hardware CRC mode 1: CRC operation processing on specified data:

Write the data needed for CRC calculation to the CRC data register CRCREG. When the CRC calculation result needs to be read, read it out from CRCDRn (n = 0~3).

CRC calculation for a single byte requires 8 system clocks, namely 0.25μs@32 MHz.

Hardware CRC mode 2: CRC calculation processing for APROM:

It can be used to generate the 32-bit CRC value of APROM (ie 64 Kbytes Flash ROM) in real time. This value is compared with the theoretical value to monitor whether the content of the program area is correct. The theoretical value of CRC does not need to be calculated by the user. The burning software will automatically complete the calculation according to the loaded code and Code area setting items and write the 4 bytes CRC32 calculation result into the CRC result storage area through the programmer during burning. The specific operation For the method, please refer to "User Manual of SinOne Development Mass Production Tool".

It takes about 16.5ms@32 MHz to calculate CRC for 64 Kbytes APROM.

The hardware CRC parameter model of SC95F861XB:

CRC algorithm name	CRC-32/MPEG-2
Polynomial formula	$x^{32}+x^{26}+x^{23}+x^{22}+x^{16}+x^{12}+x^{11}+x^{10}+x^8+x^7+x^5+x^4+x^2+x+1$
Data width	32bit
Initial value	0xFFFFFFFF
XOR value	0x00000000
Input value inversion	false
Output value inversion	false
LSB/MSB	MSB

CRC Precautions for use:

1. CRCn write data and read data are not the same;
2. The CRC value calculated by the hardware is the 32-bit CRC check value of the data in the entire program area (note that the IAP area is not included here!). If there is a residual value after the user's last operation in the address unit, it will cause the CRC value to be inconsistent with the theoretical value. Therefore, it is recommended that the user erase the entire Flash ROM before programming the code to ensure that the CRC value is consistent with the theoretical value;
3. The hardware CRC calculation range does not include the IAP area;
4. Be sure to add at least 8 NOP instructions after the CRC start operation statement to ensure that the CRC calculation is completed;
5. When performing CRC calculation, it is necessary to disable the global interrupt EA, and then reopen the global interrupt after 8 NOPs.

21.1 CRC Check Operation Related Registers

OPERCON (EFH) Operation Control Register (read/write)

Bit number	7	6	5	4	3	2	1	0
Bit Mnemonic	OPERS	MD	-	-	-	-	CRCRST	CRCSTA
R/W	R/W	R/W	-	-	-	-	R/W	R/W
POR	0	0	x	x	x	x	0	0

Bit number	Bit Mnemonic	Description
1	CRCRST	CRCn register reset (Q31~Q0) Write "1" to this bit to reset CRCn to all 1s
0	CRCSTA	CRC hardware calculation start bit Write "1" to this bit to start a check sum calculation. This bit can only be written with 1 to be valid.

The read and write operations of the CRC data register CRCDR_n (n = 0~3) are controlled by the two registers CRCINX and CRCREG. The specific position of each CRCRN is determined by CRCINX, as shown in the following table:

Symbol	Address	Description		POR
CRCINX	FCH	CRC pointer	CRCINX[7: 0]	00000000b
CRCREG	FDH	CRC register	CRCREG[7: 0]	nnnnnnnnb

Symbol	Address	Description	7	6	5	4	3	2	1	0
CRCDR3	03H@FDH	CRC Data register 3	Q31	Q30	Q29	Q28	Q27	Q26	Q25	Q24
CRCDR2	02H@FDH	CRC Data register 2	Q23	Q22	Q21	Q20	Q19	Q18	Q17	Q16
CRCDR1	01H@FDH	CRC Data register 1	Q15	Q14	Q13	Q12	Q11	Q10	Q9	Q8
CRCDR0	00H@FDH	CRC Data register 0	Q7	Q6	Q5	Q4	Q3	Q2	Q1	Q0

The related description of CRCDR_n (n = 0~3) bits is as follows:

Bit number	Bit Mnemonic	Description
Bit31~0	Qx (x = 0~31)	Hardware CRC mode 1: CRC operation processing on specified data: <ol style="list-style-type: none"> 1. You must write CRCRST first, reset CRCDR to all 1s 2. When CRCREG is written, the hardware automatically calculates the CRC result and continues to store it in CRCDR 3. When needed, read the CRC calculation result instantly

		<p>Hardware CRC mode 2: CRC calculation processing on APROM:</p> <ol style="list-style-type: none"> Started by CRCSTA, at this time the CPU automatically enters IDLE Automatically reset CRCDR to all 1: <p>The hardware CRC calculation range does not include the IAP area. The calculation range of CRC is divided into four types according to the value of IAPS[1: 0]:</p> <ol style="list-style-type: none"> IAPS[1:0]=00(Flash ROM last 0K available for IAP): 0000H ~ before last 0K IAPS[1:0]=01(Flash ROM last 1K available for IAP): 0000H ~ before last 1K IAPS[1:0]=10(Flash ROM last 1K available for IAP): 0000H ~ before last 2K IAPS[1:0]=11(Flash ROM all available for IAP): 0000H ~ All Flash ROM <ol style="list-style-type: none"> After the end, the CPU automatically exits IDLE, you can read the CRC calculation result <p>Note: Write data and read data are not the same data.</p>
--	--	---

When operating CRC-related SFR, the CRCINX register stores the address of the relevant CRCREG register, and the CRCREG register stores the corresponding value.

Before reading CRCREG, you need to set CRCINX and then read it. After each reading, CRCINX automatically adds 1 (0~3 cycles).

Hardware CRC mode 1 example: calculate CRC according to the data provided by the user

```
#include "intrins.h"

xdata unsigned int i;

xdata unsigned long int CRC_Result = 0x00; // Verification result

unsigned char a[16] = {0x00,0x01,0x02,0x03,0x04,0x05,
0x06,0x07,0x08,0x09,0x0A,
0x0B,0x0C,0x0D,0x0E,0x0F}; // The value to be verified
```



```
typedef struct
```

```
{
```

```
    char a3; // Highest address
```

```
    char a2; // Second highest address
```

```
    char a1; // Second lowest address
```

```
    char a0; // Lowest address
```

```
}Value_Typedef;
```

```
typedef union
```

```
{
```

```
    Value_Typedef reg;
```

```
    unsigned long int result; // Final Results
```

```
}Result_Typedef;
```

```
Result_Typedef CRC_Result;
```

```
    EA = 0; // Disable the global interrupt
```

```
    OPERCON |= 0x02; // Start software inspection
```

```
    _nop(); // At least 8 NOP instructions
```

```
    _nop();
```

```
    _nop();
```

```
    _nop();
```

```
    _nop();
```

```
    _nop();
```

```
    _nop();
```

```
    _nop();
```

```
    _nop();
```

```
    _nop();
```

```
    for(i=0; i<16; i++)
```

```
    {
```

```
CRCREG = a[i];    // Calculated value
_nop_();         // At least 8 NOP instructions
_nop_();
_nop_();
_nop_();
_nop_();
_nop_();
_nop_();
_nop_();
_nop_();
_nop_();
_nop_();
}

CRCINX = 0x00;

CRC_Result.reg.a0 = CRCREG;
CRC_Result.reg.a1 = CRCREG;
CRC_Result.reg.a2 = CRCREG;
CRC_Result.reg.a3 = CRCREG;

temp = CRC_Result.result; // Get results

EA = 1;          // Enable global interrupt
```

Hardware CRC mode 2 routines: generate APROM CRC in real time

```
#include "intrins.h"

typedef struct
{
    char a3; // Highest address

    char a2; // Second highest address

    char a1; // Second lowest address

    char a0; // Lowest address

}Value_Typedef;
```

```
typedef union
{
    Value_Typedef reg;
    unsigned long int result; //Final Results
}Result_Typedef;

unsigned long int temp = 0x00;
Result_Typedef CRC_Result;

    EA = 0;           // Disable global interrupts
OPERCON |= 0x01;    // Start hardware verification
_nop_();           // At least 8 NOP instructions
_nop_();
_nop_();
_nop_();
_nop_();
_nop_();
_nop_();
_nop_();
_nop_();

CRCINX = 0x00;
CRC_Result.reg.a0 = CRCREG;
CRC_Result.reg.a1 = CRCREG;
CRC_Result.reg.a2 = CRCREG;
CRC_Result.reg.a3 = CRCREG;

    temp = CRC_Result.result; // Get results
    EA = 1;           // Enable global interrupt
```

Note: It is prohibited to write values other than the CRC register address to the CRCINX register! Otherwise it will cause abnormal system operation!

22 Multiplier-Divider Unit (MDU)

The SC95F861XB provides a 16-bit hardware multiplier and divider, which consists of extended accumulators EXA0~EXA3, extended B register EXB and operation control register OPERCON. It can replace software for 16-bit \times 16-bit multiplication and 32-bit/16-bit division.

The SC95F861XB hardware multiplier and divider does not occupy CPU cycles, and the operation is implemented by hardware. The speed is dozens of times faster than the software implementation of multiplication and division. It can replace software for 16-bit \times 16-bit multiplication and 32-bit/16-bit division and increase program running efficiency.

Symbol	Address	Description	7	6	5	4	3	2	1	0	POR
EXA0	E9H	Extended Accumulator 0	EXA [7: 0]								0000000b
EXA1	EAH	Extended Accumulator 1	EXA [15: 8]								0000000b
EXA2	EBH	Extended Accumulator 2	EXA [23: 16]								0000000b
EXA3	ECH	Extended Accumulator 3	EXA [31: 24]								0000000b
EXBL	EDH	Extended B register L	EXB [7: 0]								0000000b
EXBH	EEH	Extended B register H	EXB [15: 8]								0000000b
OPERCON	EFH	Operation control register	OPE RS	MD	-	-	-	-	CRCR ST	CRCS TA	00xxxx00b

OPERCON (EFH) Operation control register (read/write)

Bit number	7	6	5	4	3	2	1	0
------------	---	---	---	---	---	---	---	---

Bit Mnemonic	OPERS	MD	-	-	-	-	CRCRST	CRCSTA
R/W	R/W	R/W	-	-	-	-	R/W	R/W
POR	0	0	x	x	x	x	0	0

Bit number	Bit Mnemonic	Description																														
7	OPERS	<p>Multiplier-divider operation start trigger control (Operater Start)</p> <p>Write "1" to this bit to start a multiplication and division calculation, that is, this bit is just the trigger signal for the multiplication and division to start calculation. When the bit is zero, it means that the calculation has been completed. This bit can only be written to 1 valid.</p>																														
6	MD	<p>Multiplication and division</p> <p>0: Multiplication operation. The multiplicand and multiplier are written and the product is read as follows:</p> <table border="1" data-bbox="609 1214 1452 1691"> <thead> <tr> <th>Byte Operand</th> <th>Byte 3</th> <th>Byte 2</th> <th>Byte 1</th> <th>Byte 0</th> </tr> </thead> <tbody> <tr> <td>multiplicand 16bit</td> <td>-</td> <td>-</td> <td>EXA1</td> <td>EXA0</td> </tr> <tr> <td>multiplier 16bit</td> <td>-</td> <td>-</td> <td>EXBH</td> <td>EXBL</td> </tr> <tr> <td>multiplier 32bit</td> <td>EXA3</td> <td>EXA2</td> <td>EXA1</td> <td>EXA0</td> </tr> </tbody> </table> <p>1: Divide operation, write the dividend and divisor, read the quotient and remainder as follows:</p> <table border="1" data-bbox="609 1879 1452 2033"> <thead> <tr> <th>Byte Operand</th> <th>Byte 3</th> <th>Byte 2</th> <th>Byte 1</th> <th>Byte 0</th> </tr> </thead> <tbody> <tr> <td> </td> <td> </td> <td> </td> <td> </td> <td> </td> </tr> </tbody> </table>	Byte Operand	Byte 3	Byte 2	Byte 1	Byte 0	multiplicand 16bit	-	-	EXA1	EXA0	multiplier 16bit	-	-	EXBH	EXBL	multiplier 32bit	EXA3	EXA2	EXA1	EXA0	Byte Operand	Byte 3	Byte 2	Byte 1	Byte 0					
Byte Operand	Byte 3	Byte 2	Byte 1	Byte 0																												
multiplicand 16bit	-	-	EXA1	EXA0																												
multiplier 16bit	-	-	EXBH	EXBL																												
multiplier 32bit	EXA3	EXA2	EXA1	EXA0																												
Byte Operand	Byte 3	Byte 2	Byte 1	Byte 0																												

		dividend 32bit	EXA3	EXA2	EXA1	EXA0
		divisor 16bit	-	-	EXBH	EXBL
		quotient 32bit	EXA3	EXA2	EXA1	EXA0
		remainder 16bit	-	-	EXBH	EXBL

Note:

1. It is forbidden to perform read or write operations on the EXA and EXB data registers during the calculation operation.
2. The time required for the operation conversion of the multiplier-divider is $16/f_{sys}$.

23 Electrical Characteristics

23.1 Absolute Maximum Ratings

Symbol	Parameter	Min Value	Max Value	UNIT
VDD/VSS	DC supply voltage	-0.3	5.5	V
Voltage ON any Pin	Input/output voltage of any pin	-0.3	V _{DD} +0.3	V
T _A	Operating temperature	-40	105	°C
T _{STG}	Storage temperature	-55	125	°C
I _{VDD}	Current value flowing through VDD	-	200	mA
I _{VSS}	Current value flowing through VSS	-	200	mA

23.2 Recommended Operating Conditions

Symbol	Parameter	Min Value	Max Value	UNIT	System Clock frequency
V _{DD}	Operating Voltage	2.0	5.5	V	32 MHz
T _A	Operating temperature	-40	105	°C	

23.3 Flash ROM Characteristics

Symbol	Parameter	Min Value	Typical Values	Max Value	UNIT	Condition
N_{END}	Wipe the number	100,000	-	-	Cycle s	
T_{DR}	Data Retention Time	100	-	-	Years	$T_A = +25^{\circ}C$
$T_{S-Erase}$	Sector Erase Time	-	5	-	ms	$T_A = +25^{\circ}C$
T_{Erase}	All Chip Erase Time	30	-	40	ms	$T_A = +25^{\circ}C$
T_{Write}	Byte Program Time	-	150	-	μs	$T_A = +25^{\circ}C$

23.4 DC Characteristics

($V_{DD} = 5V, T_A = +25^{\circ}C$, Unless otherwise specified)

Symbol	Parameter	Minimum	Typical value	Maximum	Unit	Test Conditions
Current						
I_{op1}	Operating current	-	6	-	mA	$f_{sys}=32$ MHz
I_{op2}	Operating current	-	3.8	-	mA	$f_{sys}=16$ MHz
I_{op3}	Operating current	-	2.4	-	mA	$f_{sys}=8$ MHz
I_{op4}	Operating current	-	1.7	-	mA	$f_{sys}=4$ MHz
I_{pd1}	Stand-by current	-	2.2	-	μA	

	(Power Down Mode)					
I _{IDL1}	Stand-by current (IDLE Mode)	-	2.2	-	mA	f _{sys} =32 MHz
I _{BTM}	Base Timer Operating current	-	1.3	3	μA	BTMFS[3: 0]= 1000 Generate an interrupt every 4.0 seconds
I _{WDT}	WDT current	-	1.3	3	μA	WDTCKS[2: 0]= 000 WDT overflow time 500ms
I _{TK1}	High sensitivity TK operating current	-	0.8	1.2	mA	
IO port characteristics						
V _{IH1}	Input high voltage	0.7V _{DD}	-	V _{DD} +0.3	V	GPIO
V _{IL1}	Input low voltage	-0.3	-	0.3V _{DD}	V	
V _{IH2}	Input high voltage	0.8V _{DD}	-	V _{DD}	V	Schmitt trigger input: RST
V _{IL2}	Input low voltage	-0.2	-	0.2V _{DD}	V	t _{CK} / t _{DIO} UART0 input RX0 USCI signal input port INT0~2

						PWM fault detection FLT Timer clock input port Timer capture port
I _{OL1}	Output low current	-	27	-	mA	V _{Pin} =0.4V
I _{OL2}	Output low current	-	50	-	mA	V _{Pin} =0.8V
I _{OHSP10A}	SPI0 Signal port: USCK0 (P04) USTX0 (P05) USRX0 (P06) Output high current @ V _{Pin} =4.3V	-	21	-	mA	Only applicable to SPI0 data transmission
I _{OH1}	Drive capability fixed I/O group: P3H ¹ P4 P5 Output high current @ V _{Pin} =4.3V	-	10	-	mA	Pxyz=0,I _{OH} level 0 Pxyz=1,I _{OH} level 1 Pxyz=2,I _{OH} level 2 Pxyz=3,I _{OH} level 3
I _{OH2}	Drive capability can be graded IO group: P0 P1 P2 P3L ¹ Output high current @ V _{Pin} =4.3V	-	10	-	mA	Pxyz=0,I _{OH} level 0
		-	7	-	mA	Pxyz=1,I _{OH} level 1
		-	5	-	mA	Pxyz=2,I _{OH} level 2
		-	2.5	-	mA	Pxyz=3,I _{OH} level 3
I _{OHSP10B}	SPI0 Signal port: USCK0 (P04) USTX0 (P05)	-	8	-	mA	Only applicable to SPI0 data transmission

	USRX0 (P06)					
	Output high current @ $V_{Pin}=4.7V$					
I_{OH3}	Drive capability fixed I/O group: P3H ¹ P4 P5 Output high current @ $V_{Pin}=4.7V$	-	4	-	mA	Pxyz=0,IOH level 0 Pxyz=1,IOH level 1 Pxyz=2,IOH level 2 Pxyz=3,IOH level 3
I_{OH4}	Drive capability can be graded IO group: P0 P1 P2 P3L ¹ Output high current @ $V_{Pin}=4.3V$	-	4	-	mA	Pxyz=0, I_{OH} level 0
		-	3	-	mA	Pxyz=1, I_{OH} level 1
		-	2	-	mA	Pxyz=2, I_{OH} level 2
		-	1	-	mA	Pxyz=3, I_{OH} level 3
R_{PH1}	Pull-up resistor	-	30	-	k Ω	

Note:

1. H and L:

- H: the port is four bits higher.
- L: The port is four bits lower.

($V_{DD} = 3.3V, T_A = +25^\circ C$, Unless otherwise specified)

Symbol	Parameters	Min Value	Typical value	Max Value	Unit	Test condition
Current						
I_{op5}	Operating current	-	6	-	mA	fsys=32 MHz

I_{op6}	Operating current	-	3.8	-	mA	$f_{sys}=16$ MHz
I_{op7}	Operating current	-	2.4	-	mA	$f_{sys}=8$ MHz
I_{op8}	Operating current	-	1.7	-	mA	$f_{sys}=4$ MHz
I_{pd2}	Stand-by current(Power Down Mode)	-	2.2	-	μ A	
I_{IDL2}	Stand-by current (IDLE Mode)	-	2.2	-	mA	$f_{sys}=32$ MHz
I_{TK2}	High sensitivity TK operating current	-	0.7	1.0	mA	
IO port characteristics						
V_{IH3}	Input high voltage	$0.7V_{DD}$	-	$V_{DD}+0.3$	V	
V_{IL3}	Input low voltage	-0.3	-	$0.3V_{DD}$	V	
V_{IH4}	Input high voltage	$0.8V_{DD}$	-	V_{DD}	V	Schmitt trigger input: RST
V_{IL4}	Input low voltage	-0.2	-	$0.2V_{DD}$	V	tCK / tDIO UART0 input RX0 USCI signal input port INT0~2 PWM fault detection FLT Timer clock input port

						Timer capture port
I _{OL3}	Output low current	-	22	-	mA	V _{Pin} =0.4V
I _{OL4}	Output low current	-	35	-	mA	V _{Pin} =0.8V
I _{OHSP10C}	SPI0 Signal port: USCK0 (P04) USTX0 (P05) USRX0 (P06) Output high current @ V _{Pin} =3.0V	-	7	-	mA	Only applicable to SPI0 data transmission
I _{OH5}	Drive capability fixed I/O group: P3H ¹ P4 P5 Output high current @ V _{Pin} =3.0V	-	3	-	mA	P _{xyz} =0, I _{OH} level 0 P _{xyz} =1, I _{OH} level 1 P _{xyz} =2, I _{OH} level 2 P _{xyz} =3, I _{OH} level 3
I _{OH6}	Drive capability can be graded IO group: P0 P1 P2 P3L ¹ Output high current @ V _{Pin} =3.0V	-	3	-	mA	P _{xyz} =0, I _{OH} level 0
		-	2	-	mA	P _{xyz} =1, I _{OH} level 1
		-	1.5	-	mA	P _{xyz} =2, I _{OH} level 2
		-	0.8	-	mA	P _{xyz} =3, I _{OH} level 3
R _{PH2}	Pull-up resistor	-	55	-	kΩ	

Note:

1. H and L:

- H: the port is four bits higher.
- L: The port is four bits lower.

23.5 AC Characteristics

($V_{DD} = 2.0V \sim 5.5V, T_A = 25^\circ C$, Unless otherwise indicated)

Symbol	Parameters	Min Value	Typical Value	Max Value	Unit	Test condition
T_{OSC}	External 32k oscillator start-up time	-	-	1	s	External 32k crystal oscillator
T_{POR}	Power On Reset time	-	15	-	ms	
T_{PDW}	Power Down mode wake-up time	-	65	130	μs	
T_{Reset}	Reset pulse width	18	-	-	μs	Low level valid
T_{LVR}	LVR buffeting time	-	30	-	μs	
f_{HRC1}	RC oscillation stability	31.68	32	32.32	MHz	$V_{DD}=2.0\sim 5.5V$ $T_A=-40\sim 85^\circ C$
f_{HRC2}	RC oscillation stability	31.36	32	32.64	MHz	$V_{DD}=2.0\sim 5.5V$ $T_A=-40\sim 105^\circ C$

23.6 ADC Characteristics

($T_A = 25^\circ C$, Unless otherwise indicated)

Symbol	Parameters	Min Value	Typical Value	Max Value	Unit	Condition
V_{AD1}	Supply voltage 1	2.7	5.0	5.5	V	$V_{ref} = 2.048V$
V_{AD2}	Supply voltage 2	2.4	5.0	5.5	V	$V_{ref} = 1.024V$

						or Vref = V _{DD}
V _{AD3}	Power supply voltage 3	2.7	5.0	5.5	V	Vref = 2.4V
V _{REF1}	Internal reference 2.048V	2.033	2.048	2.063	V	V _{DD} = 2.7~5.5V
V _{REF2}	Internal reference 1.024V	1.004	1.024	1.044	V	V _{DD} = 2.0~5.5V
V _{REF3}	Internal reference 2.4V	2.37	2.40	2.45	V	V _{DD} = 2.7~5.5V
N _R	Precision	-	12	-	bit	GND ≤ V _{AIN} ≤ V _{DD}
V _{AIN}	ADC input voltage	GND	-	V _{DD}	V	
R _{AIN}	ADC input resistance	1	-		MΩ	V _{IN} =5V
I _{ADC1}	ADC conversion current 1	-	-	2	mA	ADC module open V _{DD} =5V
I _{ADC2}	ADC conversion current 2	-	-	1.8	mA	ADC module open V _{DD} =3.3V
DNL	Differential Non-Linearity	-	-	±3	LSB	V _{DD} =5V V _{REF} =5V
INL	Integral Non-Linearity	-	-	±3	LSB	
E _Z	Offset error	-	±3	-	LSB	
E _F	Full scale error	-	±1	-	LSB	
E _{AD}	Absolute Accuracy	-	±3	-	LSB	

T _{ADC1}	ADC conversion time 1	-	1.1	1.4	μs	f _{sys} =32 MHz LOWSP[2: 0] = 100
T _{ADC2}	ADC conversion time 2	-	1.2	1.5	μs	f _{sys} =32 MHz LOWSP[2: 0] = 101
T _{ADC3}	ADC conversion time 3	-	1.5	1.9	μs	f _{sys} =32 MHz LOWSP[2: 0] = 110
T _{ADC4}	ADC conversion time 4	-	2.0	2.6	μs	f _{sys} =32 MHz LOWSP[2: 0] = 111

23.7 Analog Comparator Characteristics

(V_{DD} = 5V, T_A = 25°C, Unless otherwise indicated)

Symbol	Parameters	Min Value	Typical Value	Max Value	Unit	Test condition
V _{CM}	Input voltage range	0	-	V _{DD}	V	
V _{OS}	Comparator offset error	-	10	30	mV	
V _{HYS}	Schmitt trigger voltage hysteresis	-	40	-	mV	
I _{CMP}	Analog comparator consumption	-	-	100	μA	V _{DD} =5V
T _{CMP}	Response time	-	-	2	μs	

24 Application Circuit

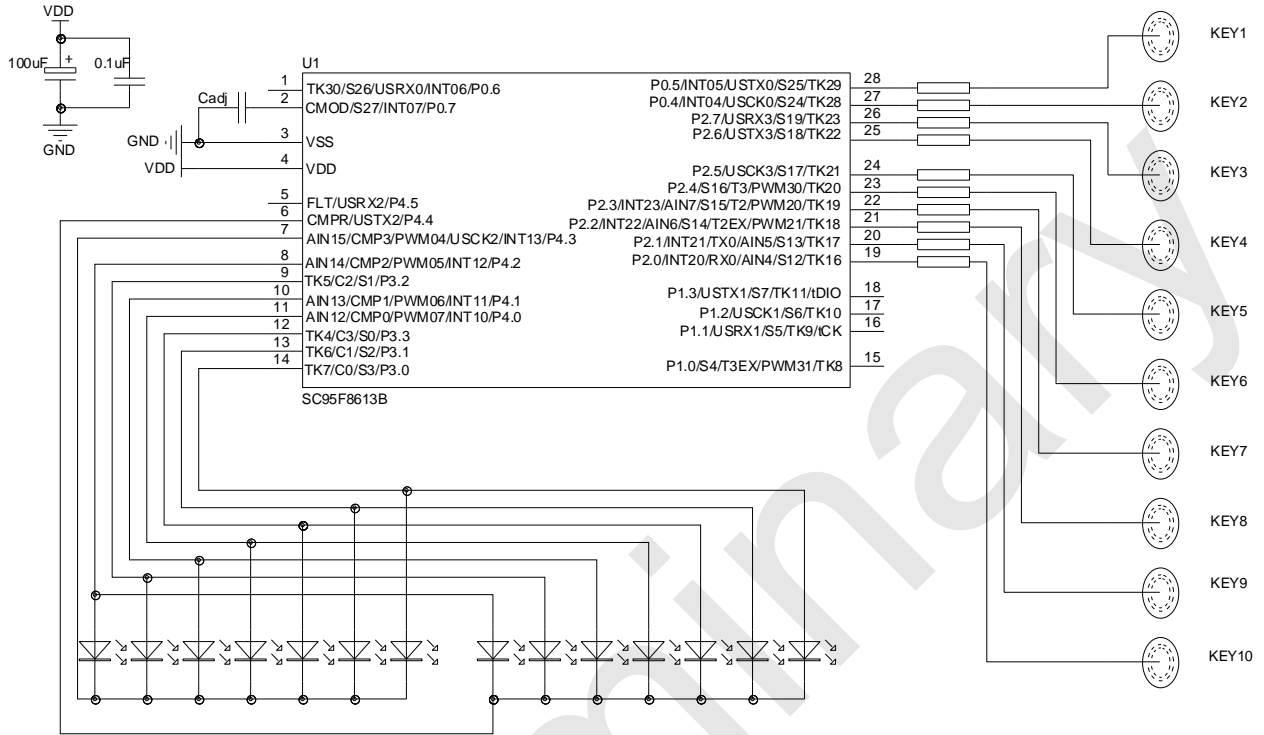

25 Package Information

SC95F8612BM20U

SOP20L(300mil) Overall Dimensions Unit: mm

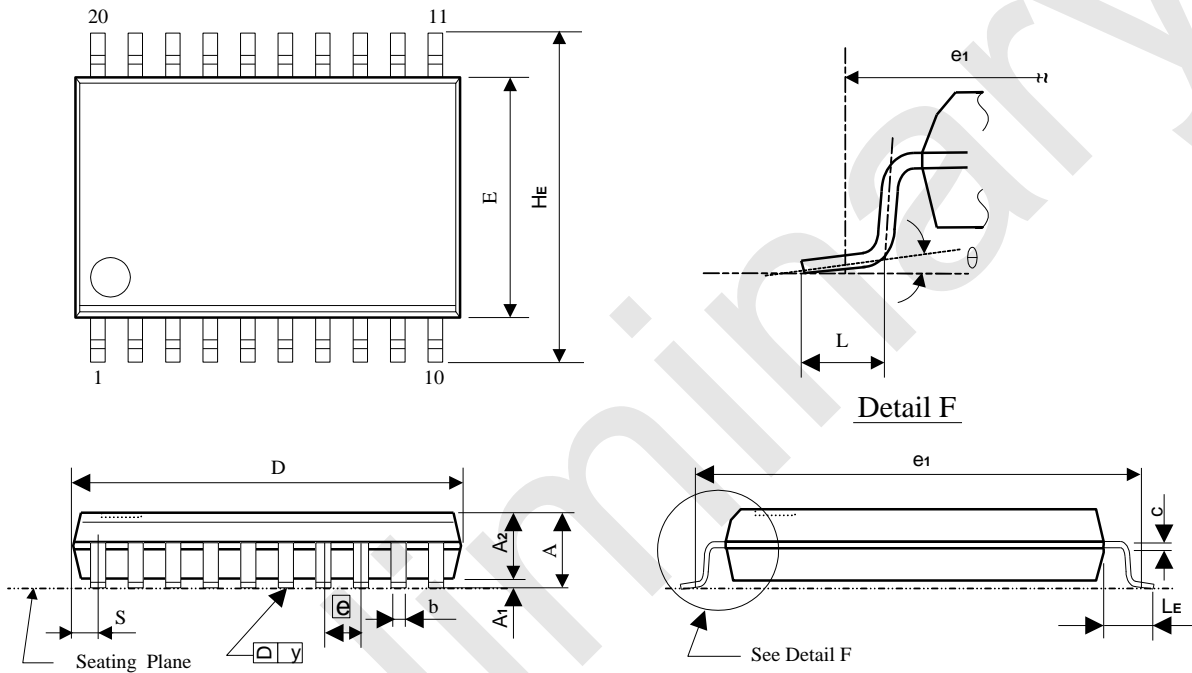

Symbol	mm		
	Min Value	Typical Value	Max Value
A	2.40	2.56	2.65
A1	0.100	0.200	0.300
A2	2.240	2.340	2.440
b	0.35	--	0.47
c	0.25	--	0.31
D	12.60	12.80	13.00
E	7.30	7.50	7.70
HE	10.100	10.300	10.500

e	1.27(BSC)		
L	0.700	0.850	1.000
LE	1.30	1.40	1.50
θ	0°	-	8°

Preliminary

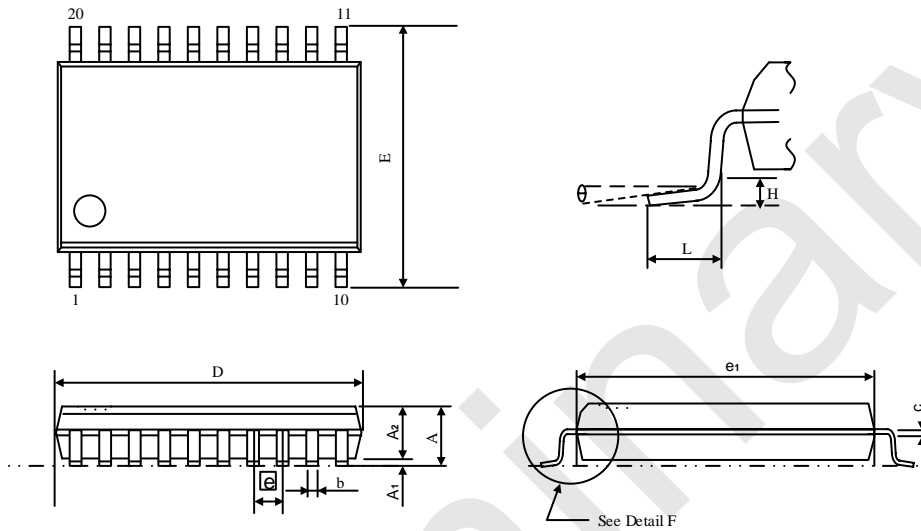
SC95F8612BX20U
TSSOP20L Overall Dimensions Unit: mm

Symbol	mm		
	Min Value	Typical Value	Max Value
A	-	-	1.200
A1	0.050	-	0.150
A2	0.800	-	1.050
b	0.190	-	0.300
c	0.090	-	0.200
D	6.400	-	6.600
E	6.20	-	6.60
e1	4.300	-	4.500
e	0.65(BSC)		
L	-	-	1.00
θ	0°	-	8°
H	0.05	-	0.15

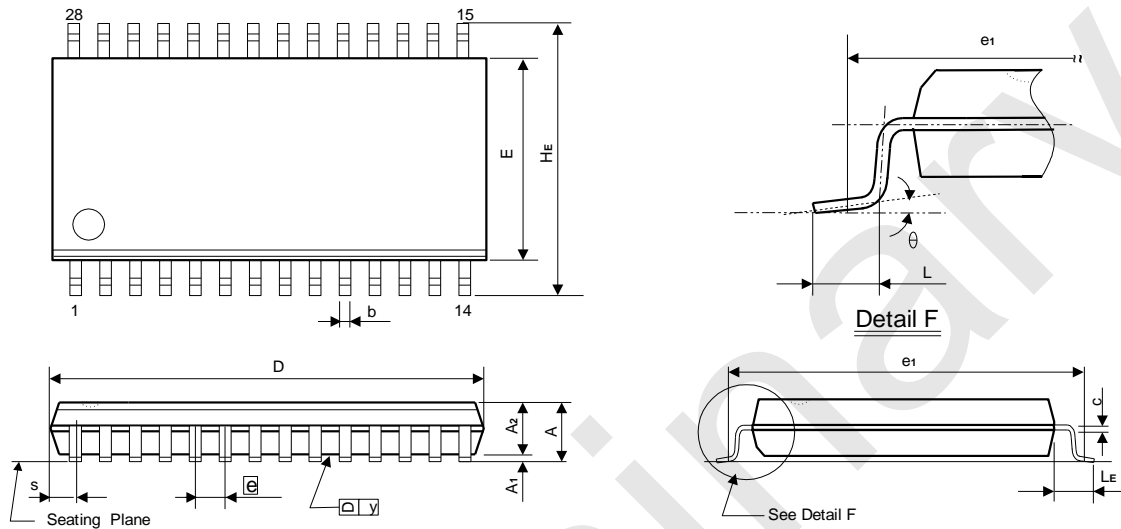
SC95F8613BM28U
SOP28L(300mil) Overall Dimensions Unit: mm

Symbol	mm		
	Min Value	Typical Value	Max Value
A	2.40	2.56	2.65
A1	0.100	0.200	0.300
A2	2.240	2.340	2.440
b	0.39	---	0.48
C	0.254(BSC)		
D	17.80	18.00	18.20
E	7.30	7.50	7.70
HE	10.100	10.300	10.500
e	1.270(BSC)		
L	0.7	0.85	1.0
LE	1.3	1.4	1.5
θ	0°	-	8°

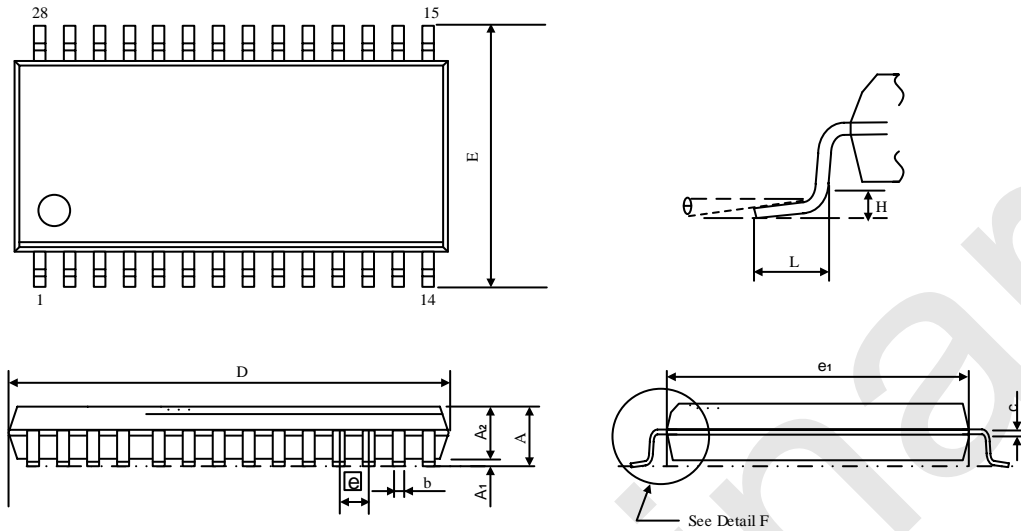
SC95F8613BX28U
TSSOP28L Overall Dimensions Unit:mm

Symbol	mm		
	Min Value	Typical Value	Max Value
A	-	-	1.200
A1	0.050	-	0.150
A2	0.800	-	1.050
b	0.190	-	0.300
c	0.090	-	0.200
D	9.600	-	9.800
E	6.250	-	6.550
e1	4.300	-	4.500
\square	0.65(BSC)		
L	-	-	1.0
θ	0°	-	8°
H	0.05	-	0.25

D1	6.85	6.95	7.05
D2	6.90	7.00	7.10
E	8.80	9.00	9.20
E1	6.85	6.95	7.05
E2	6.90	7.00	7.10
\bar{e}	--	0.8	--
L	0.43	--	0.75
L1	0.90	1.0	1.10
R	0.1	--	0.25
R1	0.1	--	--
θ	0°	--	10°
θ_1	0°	--	--
y	--	--	0.1
Z	--	0.70	--

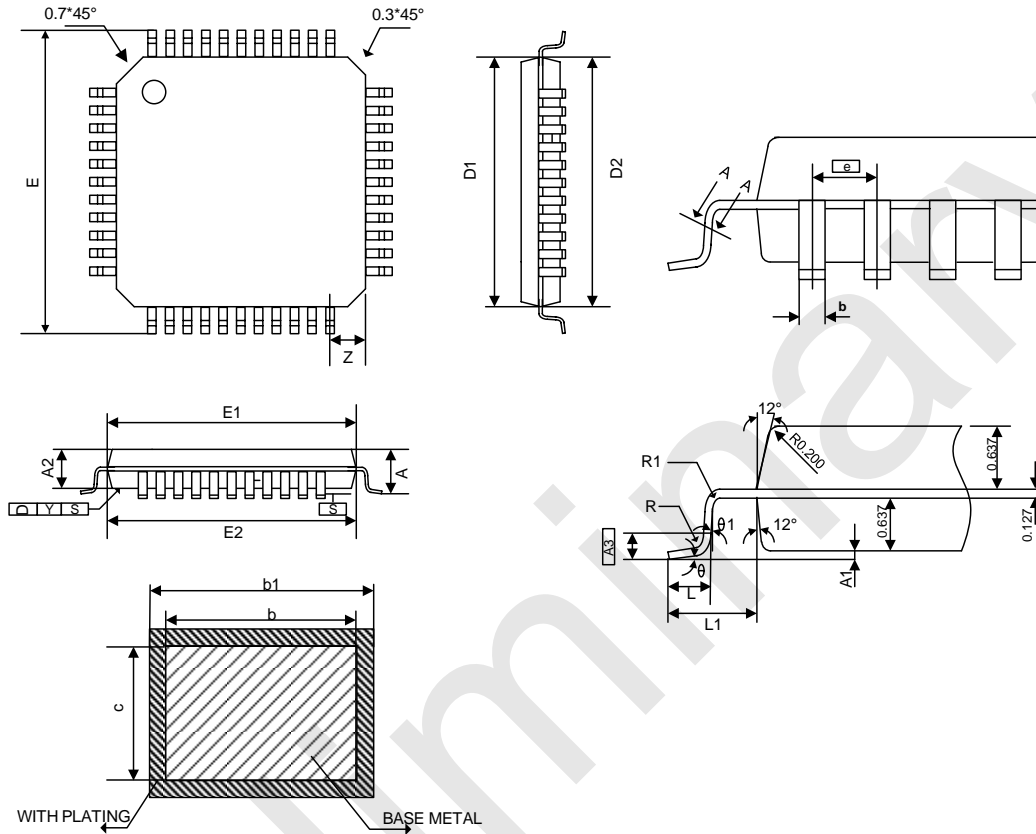
SC95F8616BP44R
LQFP44 (10X10) Overall Dimensions
Unit: mm

Symbol	mm		
	Min Value	Typical Value	Max Value
A	1.45	1.55	1.65
A1	0.015	--	0.21
A2	1.3	1.4	1.5
A3	--	0.254	--
b	0.25	0.30	0.36
b1	0.26	0.32	0.38
c	0.12	0.13	0.14
D1	9.85	9.95	10.05

D2	9.90	10.00	10.10
E	11.80	12.00	12.20
E1	9.85	9.95	10.05
E2	9.90	10.00	10.10
\bar{e}	--	0.8	--
L	0.42	--	0.75
L1	0.95	1.0	1.15
R	0.08	--	0.25
R1	0.08	--	--
θ	0°	--	10°
θ_1	0°	--	--
y	--	--	0.1
Z	--	1.0	--

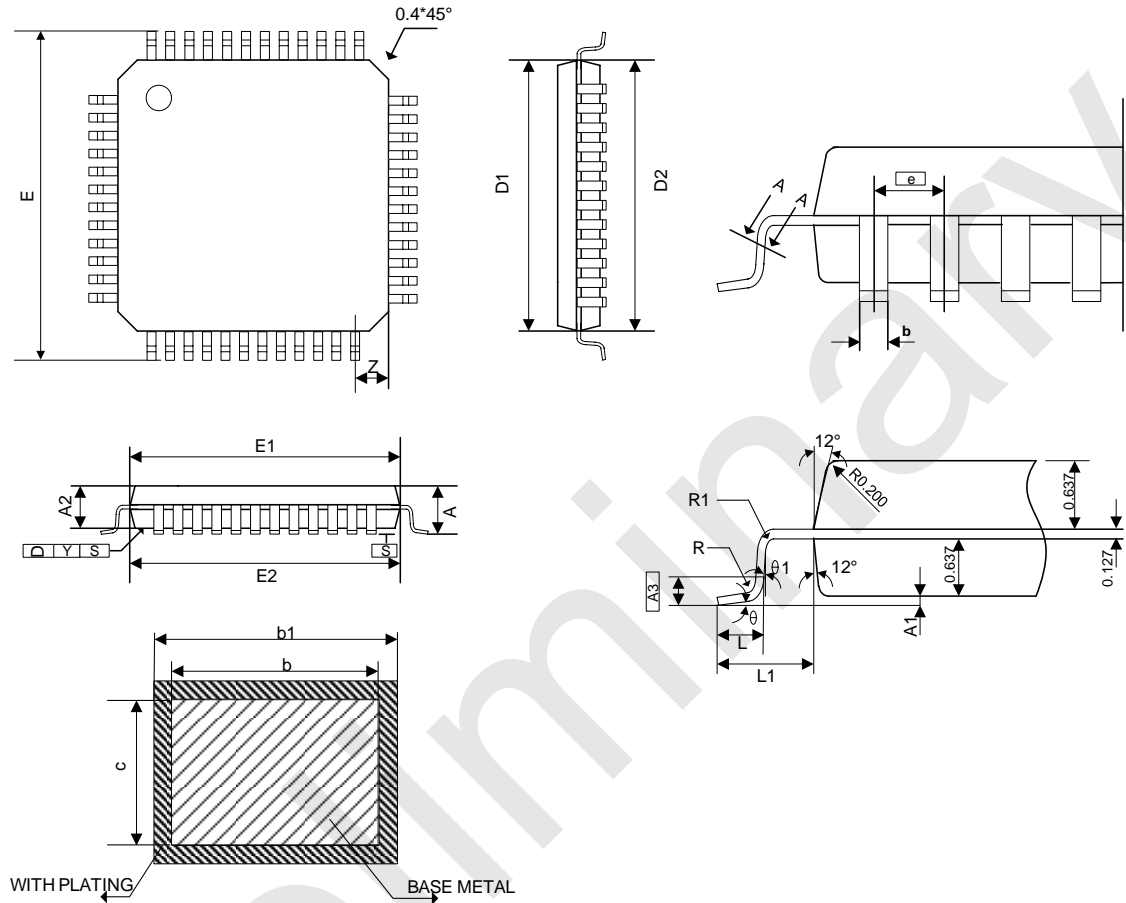
SC95F8617BP48R
LQFP48 (7X7) Overall Dimensions Unit: mm

Symbol	mm		
	Min Value	Typical Value	Max Value
A	1.45	1.55	1.65
A1	0.01	--	0.21
A2	1.3	1.4	1.5
A3	--	0.254	--
b	0.15	0.20	0.25
b1	0.16	0.22	0.28
c	0.12	--	0.17

D1	6.85	6.95	7.05
D2	6.90	7.00	7.10
E	8.8	9.00	9.20
E1	6.85	6.95	7.05
E2	6.9	7.00	7.10
e	--	0.5	--
L	0.43	--	0.75
L1	0.90	1.0	1.10
R	0.1	--	0.25
R1	0.1	--	--
θ	0°	--	10°
θ_1	0°	--	--
y	--	--	0.1
Z	--	0.75	--

26 Revision History

Revision	Changes	Date
V0.1	Initial Release.	March 2022

Preliminary

Important Notice

Shenzhen SinOne Microelectronics Co., Ltd. (hereinafter referred to as SinOne) reserves the right to change, correct, enhance, modify and improve SinOne products, documents or services at any time without prior notice. Cytron considers the information provided to be accurate and reliable. The information in this document will be used in March 2022. In the actual production design, please refer to the latest data manual of each product and other relevant materials.

Preliminary